

# ELKAY<sup>®</sup>

## SPECIFICATIONS

### Air Cooled Refrigerated Water Cooler with WaterSentry<sup>®</sup> VII Filter System Wall-Compact Models LWAE8, LWAE14

RATED FOR INDOOR USE ONLY

#### GENERAL

Self-contained, electric refrigerated, wall hung water cooler. Capacity of 50°F drinking water, based upon 80°F inlet water and 90°F ambient. Non-pressurized tank system is standard. Non-pressurized water tank is located after bubbler valve, so that tank is subject to line pressure only when valve button is pressed. Shall include the WaterSentry<sup>®</sup> VII 1500-gallon capacity filter, certified to NSF/ANSI 42 and 53. Unit shall be lead-free design which is certified to NSF/ANSI 61 and 372 and meets Federal and State low-lead requirements. Unit shall be certified to UL399 and CAN/CSA 22.2 No. 120.

#### STANDARD FEATURES

- Removable front panel offers easy accessibility to interior
- Extra deep basin minimizes splashing; with integral drain
- WaterSentry<sup>®</sup> VII 1500-gallon capacity Filtration System, certified to NSF/ANSI 42 & 53 (Lead, Class 1 Particulate, Chlorine, Taste & Odor)
- Exclusive Flexi-Guard<sup>®</sup> Safety bubbler
- Cooler Panel Finish options: Impact-resistant vinyl coating or stainless steel
- Rated for Indoor use

#### COOLING SYSTEM

- Compressor: Hermetically sealed, reciprocating type. Sealed-in lifetime lubrication.
- Condenser: Fan cooled, copper tube with aluminum fins. Fan motor is permanently lubricated.
- Cooling Unit: Combination tube-tank type. Tube portion is continuous coil of copper tubing. Fully insulated with EPS foam which meets Underwriters Laboratories Inc. Requirements for self extinguishing material.
- Refrigerant Control: Refrigerant R134a is controlled by accurately calibrated capillary tube.
- Temperature Control: Easy accessible enclosed adjustable thermostat is factory preset. Requires no adjustment other than for altitude requirements.



#### CONSTRUCTION

- Stainless Steel basin with integral drain
- Galvanized structural steel cooler chassis provides structural integrity
- Cooler cabinet available in Light Gray Granite (L), Almond (N), Sandalwood (T), or Stainless Steel (S) Panels
- Exclusive Flexi-Guard<sup>®</sup> Safety bubbler utilizes an infused anti-microbial pliable polyester elastomer to prevent accidental mouth injuries. Flexes on impact.
- Cabinet design allows for flush to wall mounting

#### REPLACEMENT FILTER:

- 51299C (single)

**Warranty:** 5 year limited warranty on the unit's refrigeration system. Electrical components and water system are warranted for 12 months from date of installation or 18 months from factory shipment, whichever date falls first.

CAPACITIES CHART						UL US	NSF/ANSI 42 and 53 Certified (Filter only)	
Model	Voltage / Hertz	Chilling** Capacity	F.L. Amps	Rated Watts	Approx. Ship Wt.	UL399 and CAN/CSA 22.2 No. 120 Certified	NSF/ANSI 61 and 372 Certified	NSF/ANSI 42 and 53 Certified (Filter only)
† LWAE8((F)1Z	115V / 60Hz	7.6 GPH	5.5	420	74 lbs.	•	•	•
† LWAE8*(F)2YJO	220V / 50Hz	7.6 GPH	2.8	420	74 lbs.	•	•	•
LWAE14*1Z	115V / 60Hz	13.5 GPH	7.2	665	74 lbs.	•	•	•
† LWAE14LF3YJO	220V / 60Hz	13.5 GPH	3.6	665	74 lbs.	•	•	•

\* Color code of (L) Light Gray Granite, (N) Almond, (S) Stainless Steel, or (T) Sandalwood cooler wrapper.

\*\*Based on 80°F inlet water & 90°F ambient air temp for 50°F chilled drinking water.

† Glass filler available at extra cost. Require factory preparation to receive glass filler

*This specification describes an Elkay product with design, quality and functional benefits to the user. When making a comparison of other producer's offerings, be certain these features are not overlooked.*

# Air Cooled Refrigerated Water Cooler with WaterSentry® VII Filter System Wall-Compact Models LWAE8, LWAE14

# ELKAY® ROUGH-IN DIMENSIONS

RATED FOR INDOOR USE ONLY

Open space rough-in design permits new installation or replacement of existing fountains and coolers with this Elkay cooler when rough-in is within the outline shown.

### IMPORTANT! INSTALLER PLEASE NOTE:

This water cooler has been designed and built to provide water to the user which has not been altered by materials in the cooler waterways.

The grounding of electrical equipment such as telephone, computers, etc to water lines is a common procedure. This grounding may be in the building or occur away from the building. This grounding can cause electrical feedback into a water cooler creating an electrolysis which creates a metallic taste or causes an increase in the metal content of the water. This condition is avoidable by installing the cooler using the proper materials as shown below.

### NOTICE

This water cooler must be connected to the water supply using a dielectric coupling. The cooler is furnished with a non-metallic strainer which meets this requirement. The drain trap, which is provided by the installer, should also be plastic to completely isolate the cooler from the building plumbing system.

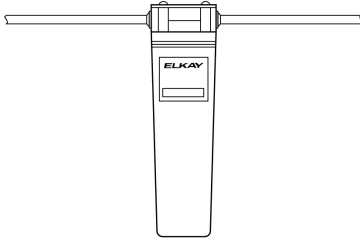

WaterSentry® VII Filter System

### TOP VIEW

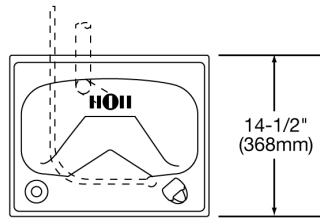

### SIDE VIEW

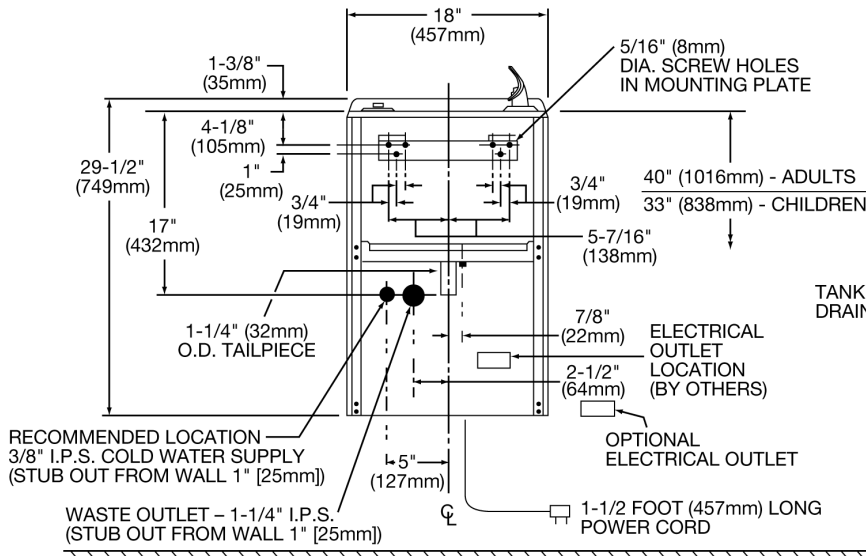
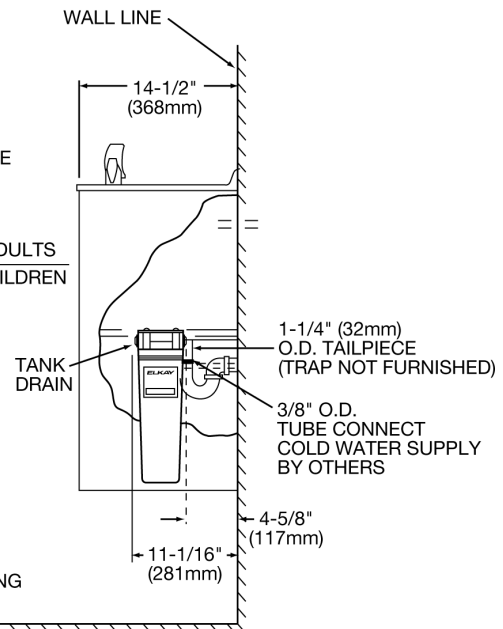

Job Name: \_\_\_\_\_  
 Model: \_\_\_\_\_ Qty. \_\_\_\_\_  
 Contact: \_\_\_\_\_  
 Approval Signature: \_\_\_\_\_  
 Notes: \_\_\_\_\_