

ELKAY®

SPECIFICATIONS



GreenSpec® Listed Two-Level Swirlflo® with WaterSentry® VII Filter System Barrier-Free Access Models LRPBGRNM28RAK and LRPBGRNMV28RAK (Reversed)

GENERAL

GreenSpec® Listed, energy and water efficient model. Two-level station barrier-free stainless steel water cooler has recessed in-the-wall refrigeration system and stainless steel grill. Stainless tubular steel support arm incorporates unique recess to be integrated with basin. All stainless steel polished to lustrous satin finish with high shined outer edge.

Fountain has contoured basin to minimize splashing, Flex-Guard® StreamSaver water-efficient bubbler and easy to operate, fully functional vandal-resistant front push button.

Flow regulator provides constant stream from 20 to 105 psi water pressure.

NOTE: Minimum 40 psi supply line pressure required in special circumstances where both sides of bi-level are in use simultaneously to ensure adequate stream height.

Energy efficient refrigeration system utilizes a combination of tank continuous-tube type evaporator, refrigerant drier, and capillary tube.

WATERSENTRY® VII FILTER SYSTEM

Elkay Water Coolers are equipped with the WaterSentry VII Filter System. Tested to NSF/ANSI Standard 53 yields a reduction of soluble and insoluble lead content to less than 0.015mg/l. This translates to lead reduction levels of 93% to 99%. Class 1 particulate reduction as tested per NSF/ANSI 42. Removes over 97.5% of free available chlorine which provides Class 1 performance as tested to NSF/ANSI 42. Provides taste and odor improvement.

THIS WATER COOLER COMPLIES WITH THE REQUIREMENTS OF A.D.A. (AMERICAN DISABILITIES ACT) WHEN PROPERLY INSTALLED.

NO LEAD DESIGN

THESE WATER COOLERS ARE CERTIFIED TO BE LEAD-FREE AS DEFINED BY THE SAFE DRINKING WATER ACT OF 1986 AND LEAD CONTAMINATION CONTROL ACT OF 1988.

Elkay Water Coolers are manufactured with a waterway system utilizing copper components and completely lead-free materials. These waterways have no lead because all lead materials, such as leaded brass, have been removed. All joints are brazed using silver solder only. No lead solder is permitted. A strainer with an easily cleanable screen is provided to allow trapping and convenient removal of waterborne particulate of 140 microns and larger prior to their entry into the water cooler.

CAPACITIES CHART

Model Number	Base Rate	**GPH of 50°F Drinking Water			Rated Watts	Full Load Amps	Glass Filler Option	Ship. Wt. Lbs.
		Room Temperature °F						
		70°F (21°C)	80°F (27°C)	90°F (32°C)				
LRPBGRNM(V)28RAK	7.5	9.3	8.3	7.5	260	2.8	No	93

**Based on 80°F (27°C) inlet water temperature.

Rated watts shown are based on operational (run) time, in accordance with A.R.I. Standard 1010 conditions. Specific applications will determine the actual watts consumed per hour. Watts consumed will be based on number of people served per hour (usage), ambient temperatures, and inlet water temperature.

COOLING SYSTEM

Motor Compressor: Hermetically sealed, reciprocating type, 115 Volt/60 Hz, single phase. Sealed-in lifetime oil supply.

Condenser: Fan cooled, copper tube with aluminum fins. Fan motor is permanently lubricated.

Cooling Unit: Combination tube-tank type. Self cleansing. Tube portion is continuous coil of copper tubing. Tank is stainless steel. Fully insulated with EPS foam which meets

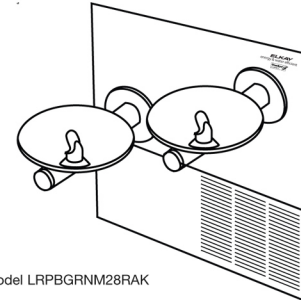

Model LRPBGRNM28RAK

Underwriters Laboratories Inc. requirements for self extinguishing material.

Refrigerant Control: Refrigerant HFC-134a is controlled by accurately calibrated capillary tube for positively trouble-free operation.

Temperature Control: Enclosed adjustable thermostat is factory preset. Requires no adjustment other than for altitude requirements.

CONSTRUCTION

Fountain Body: #18 gauge, 300 series nickel bearing stainless steel basin polished to a lustrous satin finish with high shined outer edge. Contoured basin offers large strike area to minimize splashing. #16 gauge, 300 series tubular support arm incorporates unique recess to accept basin. Fully functional vandal-resistant push button is easy to operate.

Exclusive Flex-Guard® Stream-Saver™ Bubbler: Water-efficient, innovative design utilizes a pliable polyester elastomer to prevent accidental mouth injuries. Flexes on impact, then returns to original position. Strong, abrasion-resistant. Anti-sweat. Bubbler meets UL requirements and all sanitary codes and is keyed in location to prevent rotation.

BUBBLER OPTION

Vandal-Resistant Bubbler: (option) One-piece, heavy-duty, chrome plated, solid construction. Model LRPBGRNMV28RAK.

Front Panel Grill: Made of 300 series stainless steel, polished to a uniform Elkay satin finish. Removable louvered ventilating grill encloses refrigeration unit and plumbing.

Wall Mounting Frame: MF200 frame furnished with each unit. Frame allows flush mounting to finished wall.

Protected by Elkay's 5 Year Limited Warranty on the refrigeration system of the unit.

Elkay Pressure-Type Water Coolers are designed to operate on 20 psi (138 KPa) to 105 psi (724 KPa) supply line pressure. If inlet pressure is above 105 psi (724 KPa), a pressure regulator must be installed in the supply line. Any damage caused by reason of connecting this product to supply line pressures lower than 20 psi (138 KPa) or higher than 105 psi (724 KPa) is not covered by the warranty.

STANDARDS

Elkay Electric Air Cooled Water Coolers are listed by Underwriters Laboratories Inc. and comply with both Canadian and U.S. requirements.

These units comply with A.R.I. Standard 1010.

This fountain is certified by WQA to lead-free compliance including NSF/ANSI 61 and 372.

In keeping with our policy of continuing product improvement, Elkay reserves the right to change product specifications without notice. Please visit elkayusa.com for most current version of Elkay product specification sheets.

This specification describes an Elkay product with design, quality and functional benefits to the user. When making a comparison of other producers' offerings, be certain these features are not overlooked.

GreenSpec® Listed Two-Level Swirlflo® with WaterSentry® VII Filter System Barrier-Free Access



Models LRPBGRNM28RAK and LRPBGRNMV28RAK (Reversed) ROUGH-IN DIMENSIONS

IMPORTANT!

INSTALLER PLEASE NOTE:

The grounding of electrical equipment such as telephone, computers, etc., to water lines is a common procedure. This grounding may be in the building or may occur away from the building. This grounding can cause electrical feedback into a water cooler, creating an electrolysis which causes a metallic taste or causes an increase in the metal content of the water. This condition is avoidable by using the proper materials as indicated below.

The drain fittings which are provided by the installer should also be plastic to electrically isolate the cooler from the building plumbing system.

LRPBGRNM28RAK MOUNTING FRAME INSTRUCTIONS

1. Cut a square rectangular wall opening 37-1/2" (476mm) W x 37-3/4" (959mm) H and 4-1/2" (114mm) above the floor line. These dimensions are required to obtain proper rim and bubbler heights for compliance with ANSI standard.

2. Reinforce the wall opening on all sides so that it will adequately support the water fountain. This reinforcement must support up to 150 lbs static load and provide a means for securing the frame assembly in place.

NOTE: Building construction must allow for adequate air flow on both sides and top of remote chiller unit. Minimum of 4" (102mm) is required. (See Figures 1 & 2)

3. Install plumbing and electrical rough-ins. See Figure 1 for location of the supply water inlet to chiller and for the location of the waste water outlet. A junction box for a (3) wire, 10 amp branch circuit is provided on the inside of the chiller. (Standard 120 Volts, 60 Hz and single phase) See Figure 2 for the electrical inlet location.

4. Remove frame assembly and related hardware from packaging. Attach the two frames together thru the upright supports with (4) 5/16" x 3/4" (19mm) long bolts and nuts (not provided). Tighten securely.

NOTE: Frame with higher upper channel to be on left side.

5. Install the frame assembly squarely in wall opening with frame upright support edges flush with the finished wall face. Secure the frame to the wall thru holes with (12) 5/16" x 2" (51mm) long lag bolts or screws (not provided). Tighten securely.

NOTE: Be sure that frame is squared in location. Do not use less than required screw quantity and size.

6. Attach the chiller shelf support rods to the right side frame uprights at the second set of holes counting from the bottom and to the shelf at the (2) side holes. Line up the other shelf holes with the frame bottom holes and fasten the assembly to the wall using appropriately sized wood screws or bolts and nuts (not provided). (See Figure 2)

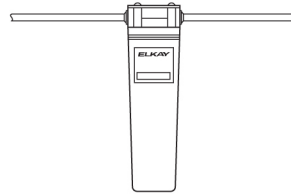

WaterSentry® VII Filter System

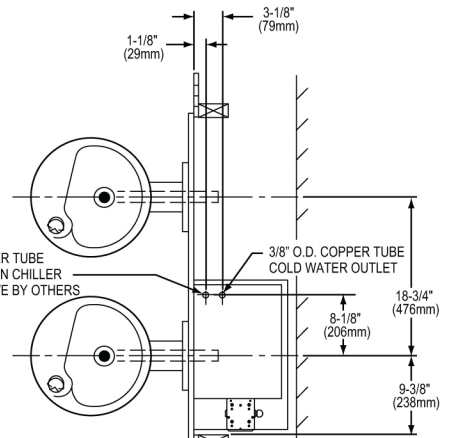
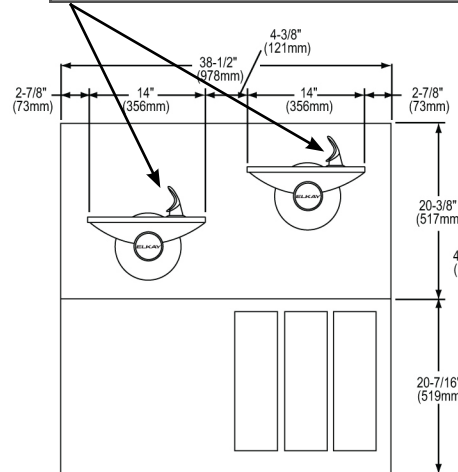
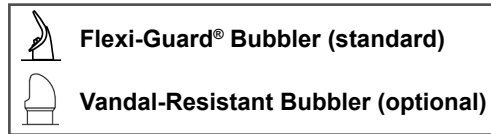
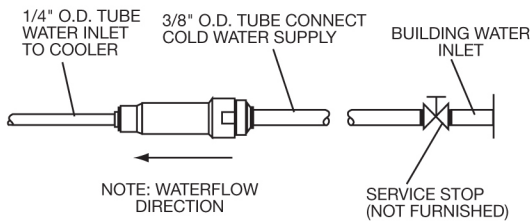

FIG. 1



FIG. 2



OPERATION OF QUICK CONNECT FITTINGS

