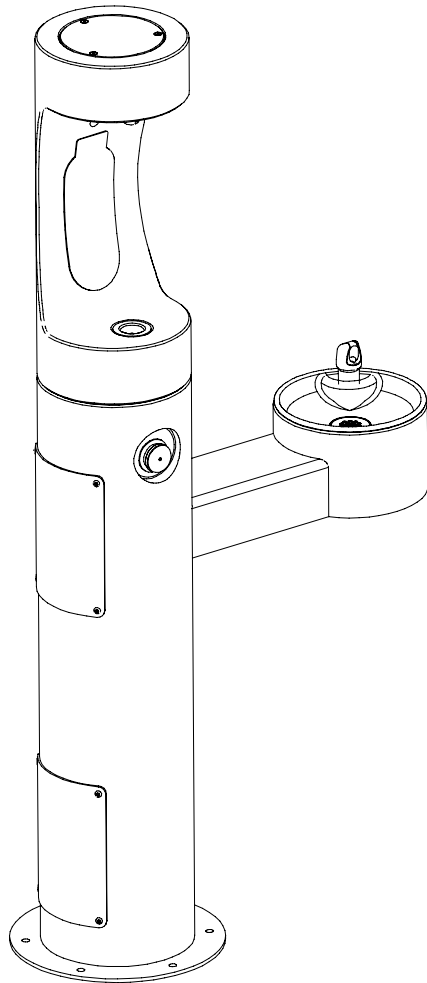


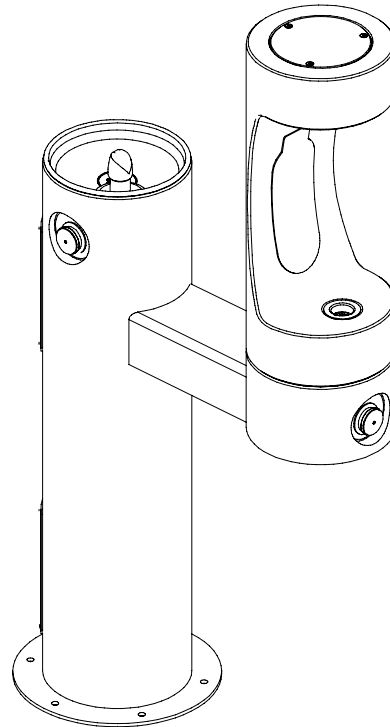
# Owners Manual

Models 4420BF1U & 4420BF1L

Floor Mounted Bi-Level Bottle Filler Tubular Fountain



Models (LK)4420BF1U\*



Models (LK)4420BF1L\*

## INSTALLER

4420BF Fountains are among the easiest to install Fountains on the market today. To assure you install these models easily and correctly, PLEASE READ THESE SIMPLE INSTRUCTIONS BEFORE STARTING THE INSTALLATION. CHECK YOUR INSTALLATION FOR COMPLIANCE WITH PLUMBING, ELECTRICAL, AND OTHER APPLICABLE CODES. After installation, leave these instructions with the Fountain for future reference.

# INSTALLATION INSTRUCTIONS

## IMPORTANT

ALL SERVICE TO BE PERFORMED BY AN AUTHORIZED SERVICE PERSON

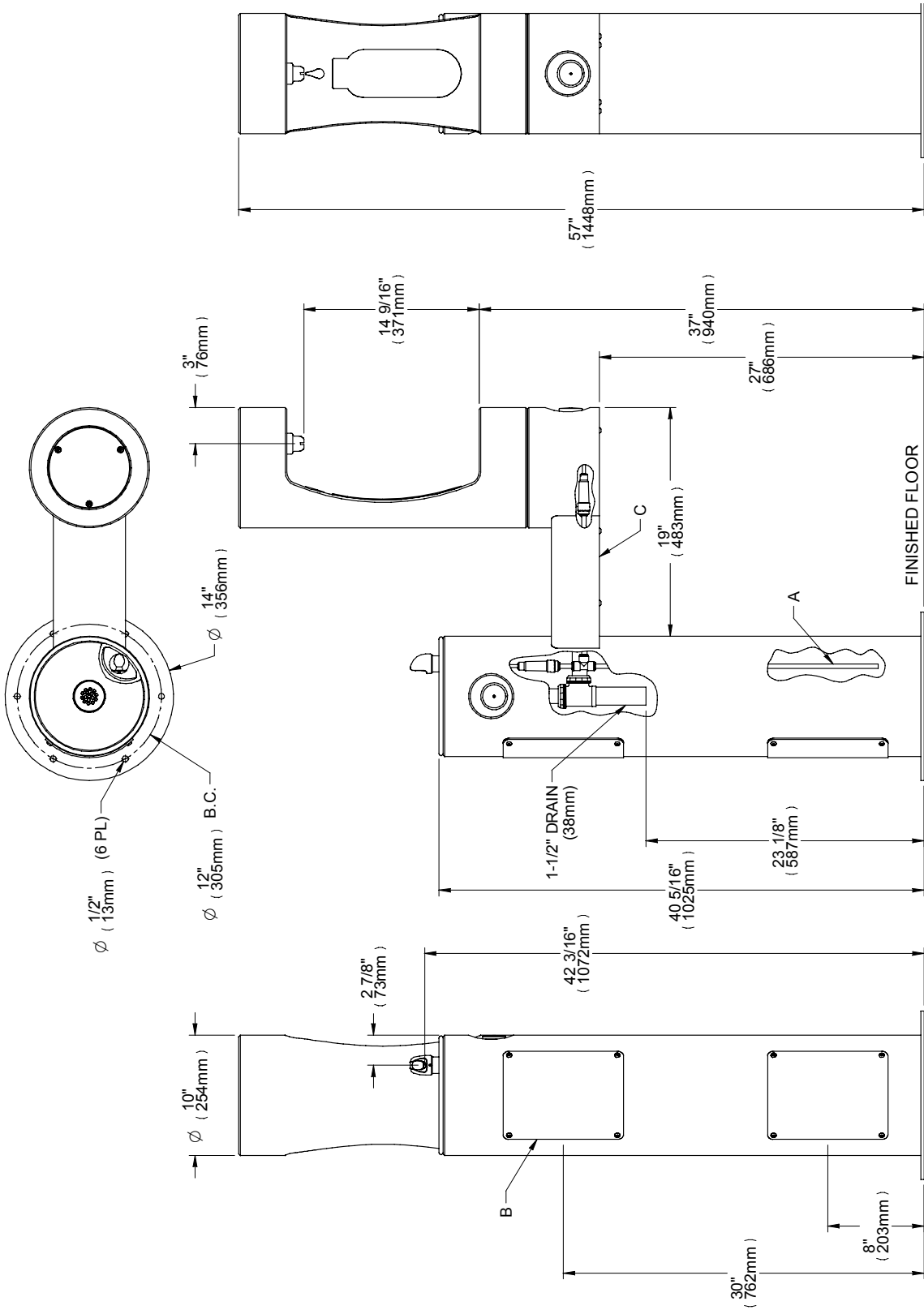
### IMPORTANT! INSTALLER PLEASE NOTE.

THE GROUNDING OF ELECTRICAL EQUIPMENT SUCH AS TELEPHONE, COMPUTERS, ETC. TO WATER LINES IS A COMMON PROCEDURE. THIS GROUNDING MAY BE IN THE BUILDING OR MAY OCCUR AWAY FROM THE BUILDING. THIS GROUNDING CAN CAUSE ELECTRICAL FEEDBACK INTO A FOUNTAIN, CREATING AN ELECTROLYSIS WHICH CAUSES A METALLIC TASTE OR AN INCREASE IN THE METAL CONTENT OF THE WATER. THIS CONDITION IS AVOIDABLE BY USING THE PROPER MATERIALS AS INDICATED. ANY DRAIN FITTINGS PROVIDED BY THE INSTALLER SHOULD BE MADE OF PLASTIC TO ELECTRICALLY ISOLATE THE FOUNTAIN FROM THE BUILDING PLUMBING SYSTEM.

1. This fountain is to be mounted on a smooth, flat, finished surface with adequate support structure. NOTE: Mounting structure must be capable of supporting 300 lb. load on fountain.
2. Refer to rough-in for plumbing.
3. Install shut-off valve on water supply. (Valve not furnished)
4. Locate and install fountain using 3/8" minimum fasteners. (Fasteners not furnished)
5. Prior to installing the bottle filler to the center mounting position of fountain, install the drain pipe (Item #11) by positioning the short end of drain pipe through mounting plate of bottle filler. Install filler onto fountain and secure with supplied mounting hardware.
6. Prior to installing the bottle filler to the arm mount of fountain, insert the drain pipe (Item #10) into the arm tunnel and adjust drain to lean to the left side of arm when facing button. Install bottle filler to arm being sure drain tube is above mounting plate of filler. Install filler onto fountain and secure with supplied mounting hardware.
7. Connect water supply and fountain drain. Connect drain waste "Tee" to fountain drain tubes. Connect outlet of "Tee" to drainage system. Connect Bottle Filler water line to regulator with the supplied 3/8" to 1/4" reducing fitting. Water connection and drain must comply with local codes.
8. Turn on water supply and check all connections for leaks.

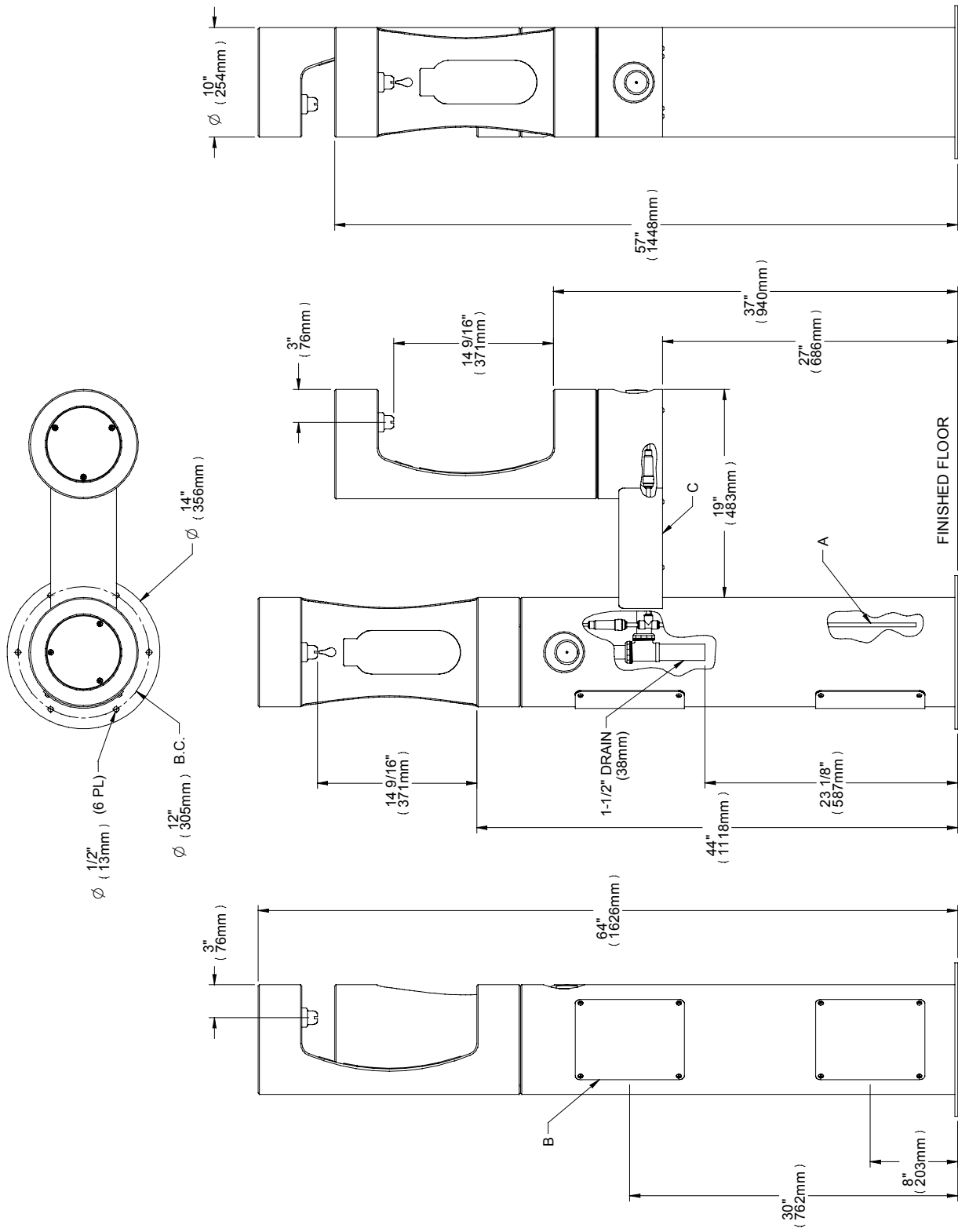
**CAUTION:** This fountain is rated for inlet water pressure of 20-105 PSI. A pressure reducing regulator should be used if the inlet water supply exceeds 105 PSI. Any damage caused by reason of connecting this product to supply line pressures lower than 20 PSI or higher than 105 PSI is not covered by warranty.

9. Water supply 3/8" O.D. unplated copper tube. Waste 1-1/2" IPS. Contractor to supply waste trap and service stop valve in accordance with local code.
10. Connecting lines to be made of unplated copper and should be thoroughly flushed to remove all foreign matter before being connected to fountain. This fountain is manufactured in such a manner that it does not in any way cause taste, odor, color, or sediment problems.
11. Connect fountain to supply line with a shut-off valve and install a 3/8" unplated copper water line between the valve and the cooler. Remove any burrs from outside of water line. Push the tubes straight into the fittings until they reach a positive stop, approximately 3/4" (See Fig. 2). DO NOT SOLDER TUBES INSERTED INTO PLASTIC FITTINGS AS DAMAGE TO THE O-RINGS MAY RESULT.

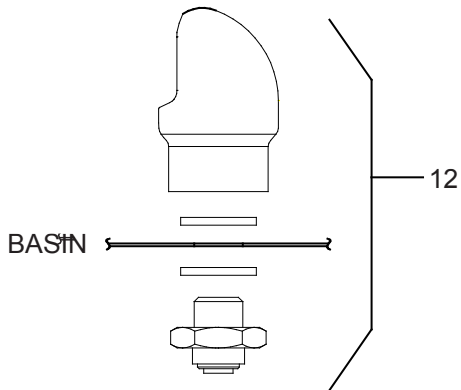
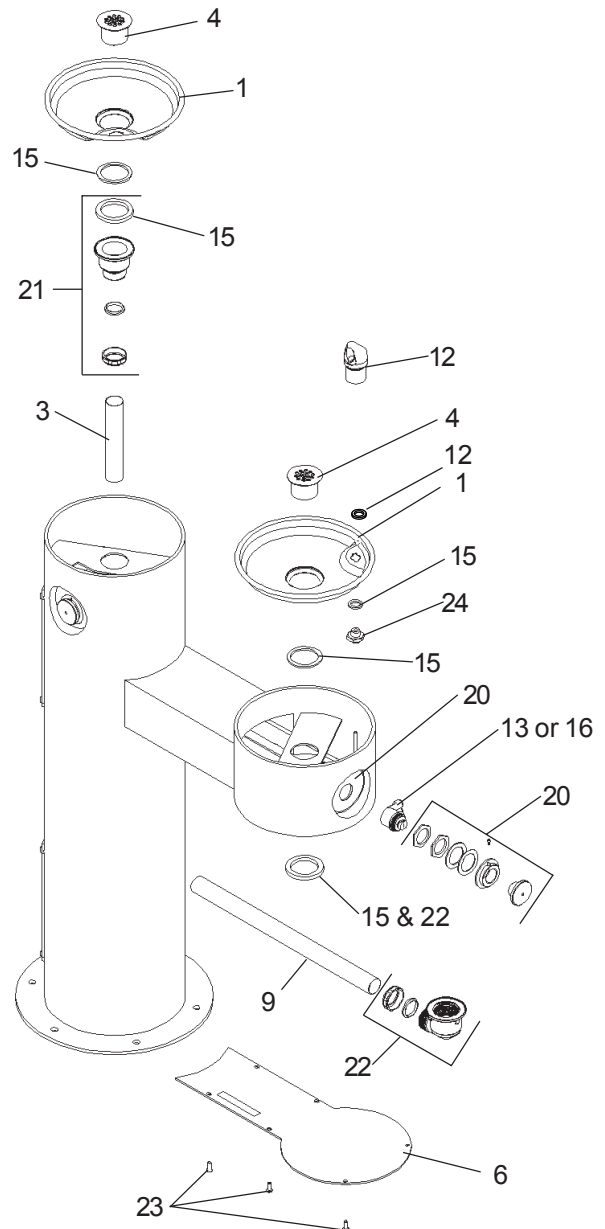
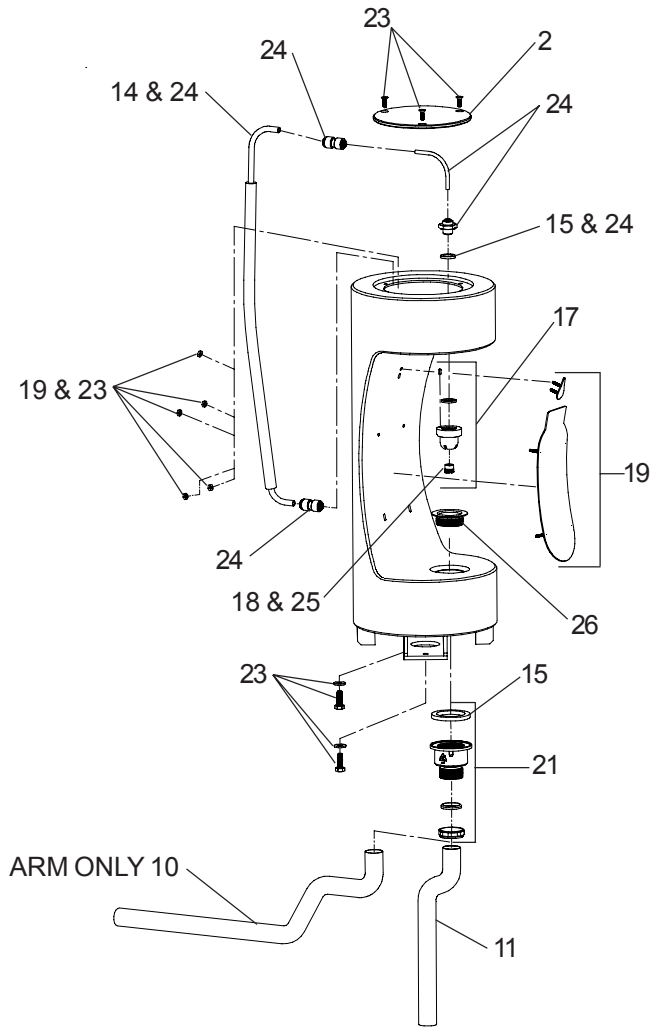


4420BF1U

**LEGEND**  
 A = 3/8" O.D. UNPLATED COPPER TUBE CONNECT - SHUT OFF VALVE BY OTHERS  
 B = ACCESS PANEL ( 8" X 10" )  
 C = REMOVABLE BOTTOM COVER



**LEGEND**  
 A = 3/8" O.D. UNPLATED COPPER TUBE CONNECT - SHUT OFF VALVE BY OTHERS  
 B = ACCESS PANEL ( 8" X 10" )  
 C = REMOVABLE BOTTOM COVER

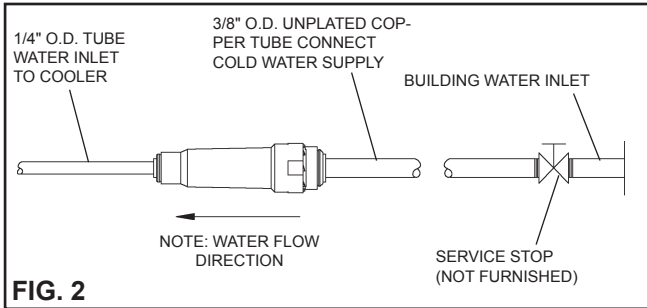


Vandal-Resistant Bubbler  
FIG. 1

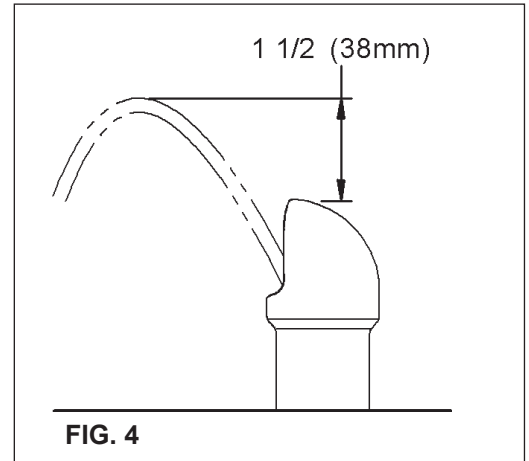
**TROUBLE SHOOTING AND MAINTENANCE**

**ACTUATION OF QUICK CONNECT WATER FITTINGS:**

Fountain is provided with lead-free connectors which utilize an o-ring water seal. To remove tubing from the fitting, relieve water pressure, push in on the gray collar while pulling on the tubing. (see Fig.3) To insert tubing, push tube straight into fitting until it reaches a positive stop, approximately 3/4".

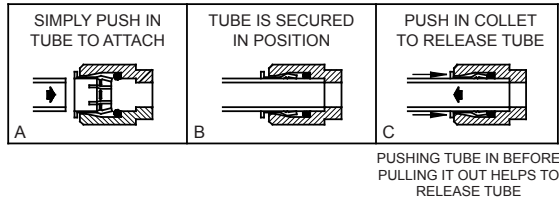


**FIG. 2**



**FIG. 4**

**OPERATION OF QUICK CONNECT FITTINGS**



**FIG. 3**

**STREAM HEIGHT ADJUSTMENT:**

Stream height is factory set at 35 PSI. If supply pressure varies greatly from this, insert a small straight bladed screwdriver through the access hole in the center of the push button and turn the adjustment screw. Clockwise adjustment will raise the stream and counterclockwise adjustment will lower the stream. For best adjustment, the stream should be approximately 1 1/2" above the top of the bubbler. (See Fig. 4)

**ITEMIZED PARTS LIST**

ITEM NO.	PART NO.	DESCRIPTION
1	28467C	Basin
2	28955C*	Cover - Round Plate
3	40551C	Tailpipe
4	45464C	Drain Plug 1-1/2"
5	45832C*	Access Panel
6	45833C	Bottom Cover
7	45476C	Drain Tube
8	55996C	In - Line Strainer
9	66346C	Drain Tube
10	66816C	Tube - Drain (Arm Only)
11	66815C	Tube - Drain
12	97446C	Kit - Bubbler (VR)
13	98530C	Kit - Regulator W/Spring
14	98532C	Kit - "O" Rings and Fittings
15	98677C	Kit - Gasket
16	98678C	Kit - 1.0 GPM Regulator (BF Only)
17	98679C	Kit - Nozzle
18	98680C	Kit - Aerator
19	98681C	Kit - Bottle Filler Trim
20	98682C	Kit - Push Button
21	98683C	Kit - Plastic Drain
22	98684C	Kit - 90° Plastic Drain
23	98685C	Kit - 4400 Series Hardware
24	98686C	Kit - Bottle Filler Waterway
25	P05031	Aerator
26	45931C	Outdoor Bottle Filler Drain Plug

\*select color option to complete part number

**\*FINISH COLOR OPTIONS** - Choose color option to complete your model number, add as suffix example: 4420BF~~EVG~~

Matte finish:  Evergreen = **EVG**

Gloss finish:

- Beige = **BGE**
- Black = **BLK**
- Blue = **BLU**
- Brown = **BRN**
- Gray = **GRY**
- Orange = **ORN**
- Purple = **PUR**
- Red = **RED**
- Terracotta = **TER**
- White = **WHT**
- Yellow = **YLW**

