

ELKAY[®] SPECIFICATIONS

MODEL LK4400BFFRK

GENERAL

Steel Outdoor Freeze-Resistant Pedestal Fountain with Bottle Filling Station with rounded corner design, heavy-duty steel with textured powder-coat finish and E-Coat immersion for year-round beauty with minimum maintenance. The E-Coat immersion process coats the inside and outside for the ultimate in corrosion protection.

BOTTLE FILLER

Provides a quick fill at 1 gallon per minute. Laminar flow provides a clean fill with minimal splash and easy maintenance.

FREEZE-RESISTANT VALVE SYSTEM

Designed for ground installation 21" minimum below the frost line. 60" of access tubing provided with the freeze-resistant valve system. The length of tubing can be adjusted in the field for lesser frost depths.

PUSHBUTTON ACTUATION MECHANISM

Self-closing, vandal-resistant pushbutton does not require grasping or twisting.

WATER INLET & DRAIN OUTLET

Inlet: 1/4" O.D. Tubing



Outlet: 1-1/4" tube outlet for 1-1/4" slip joint connection

ACCESS PANELS

Heavy-gauge steel with vandal-resistant screws. Provides access for easy hook-up of all plumbing connections.

SUGGESTED SPECIFICATIONS

Unit shall include powder-coated finish with vandal-resistant pushbutton actuation, Bottle Filler shall include a laminar flow for minimal splash and provide 1 gallon per minute fill rate. The manufacturer shall certify the unit to meet the requirements of NSF/ANSI 61, and the Safe Drinking Water Act.

Model	Color Option		
		ADA Compliant	NSF/ANSI 61 Certified
LK4400BFFRK*	(Refer to Finish Color Options)	•	•

* Select color option to complete model number. Example: LK4400BFFRKEVG

Each 4400 FR consists of 2 cartons of the following:

- Fountain
- Single Freeze-Resistant Valve System - 98836C

This specification describes an Elkay product with design, quality and functional benefits to the user. When making a comparison of other producer's offerings, be certain these features are not overlooked.

In keeping with our policy of continuing product improvement, Elkay reserves the right to change specification without notice. Please visit elkay.com for the most current version.

2222 Camden Court
Oak Brook, IL 60523
630-572-3192
elkay.com

Outdoor Tubular Bottle Filling Station

Freeze-Resistant Pedestal Fountain



Model LK4400BFFRK is shown.

Now Available
in 12 Colors!



FINISH COLOR OPTIONS – Choose color option to complete your model number, add as suffix example: LK4400BFFRKEVG

Matte finish: Evergreen = EVG

Gloss finish:

- | | | |
|--------------------------------------|---------------------------------------|---|
| <input type="checkbox"/> Beige = BGE | <input type="checkbox"/> Gray = GRY | <input type="checkbox"/> Terracotta = TER |
| <input type="checkbox"/> Black = BLK | <input type="checkbox"/> Orange = ORN | <input type="checkbox"/> White = WHT |
| <input type="checkbox"/> Blue = BLU | <input type="checkbox"/> Purple = PUR | <input type="checkbox"/> Yellow = YLW |
| <input type="checkbox"/> Brown = BRN | <input type="checkbox"/> Red = RED | |

OPTIONS

- Hose Bib (Locking) - LK4471LHB* (Choose color option to complete your model number)
- Hose Bib (Non-Locking) - LK4470NLHB* (Choose color option to complete your model number)
- Direct Bury Kit - 97890C

MODEL LK4400BFFRK

Outdoor Tubular Freeze-Resistant Bottle Filling Station

OPERATING PRESSURES:
Supply water 20 – 105 psi maximum

MOUNTING INSTRUCTIONS and PLUMBING INSTRUCTIONS

Site and drainage excavation is required for fountain installation. Refer to owner's manual for site preparation details. Provide solid, well-drained smooth, flat, finished surface to mount pedestal fountain (concrete pad recommended) with adequate support (300 lb. load minimum). (6) 3/8" minimum fasteners (not included) should be attached securely to mounting surface in order to secure fountain, (Refer to rough-in diagram), and be sure to allow an opening for the freeze-resistant valve in the ground as shown in the installation instructions that accompany the fountain. (Refer to the rough-in diagram below). Refer to local codes for any additional requirements.

Locate and install plumbing through ground as required. Assemble fountain to prepared site and mounting pad.

NOTE: Fountain is not furnished with service valve.

Position pedestal over plumbing and secure base to fasteners. Remove access panels and connect supply and water lines. Turn on water supply and check for leaks. Refer to owner's manual for detailed instructions. Reassemble access panels to pedestal.

Trap and service stop not included.

TOP VIEW

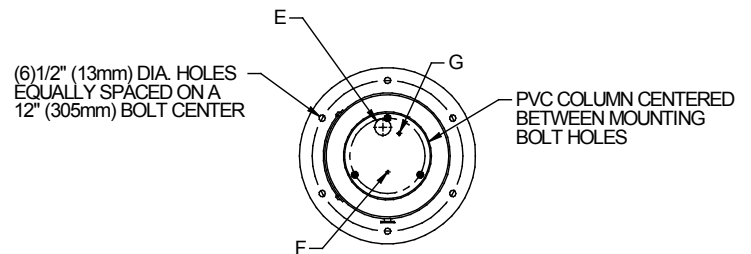

SIDE & FRONT VIEWS

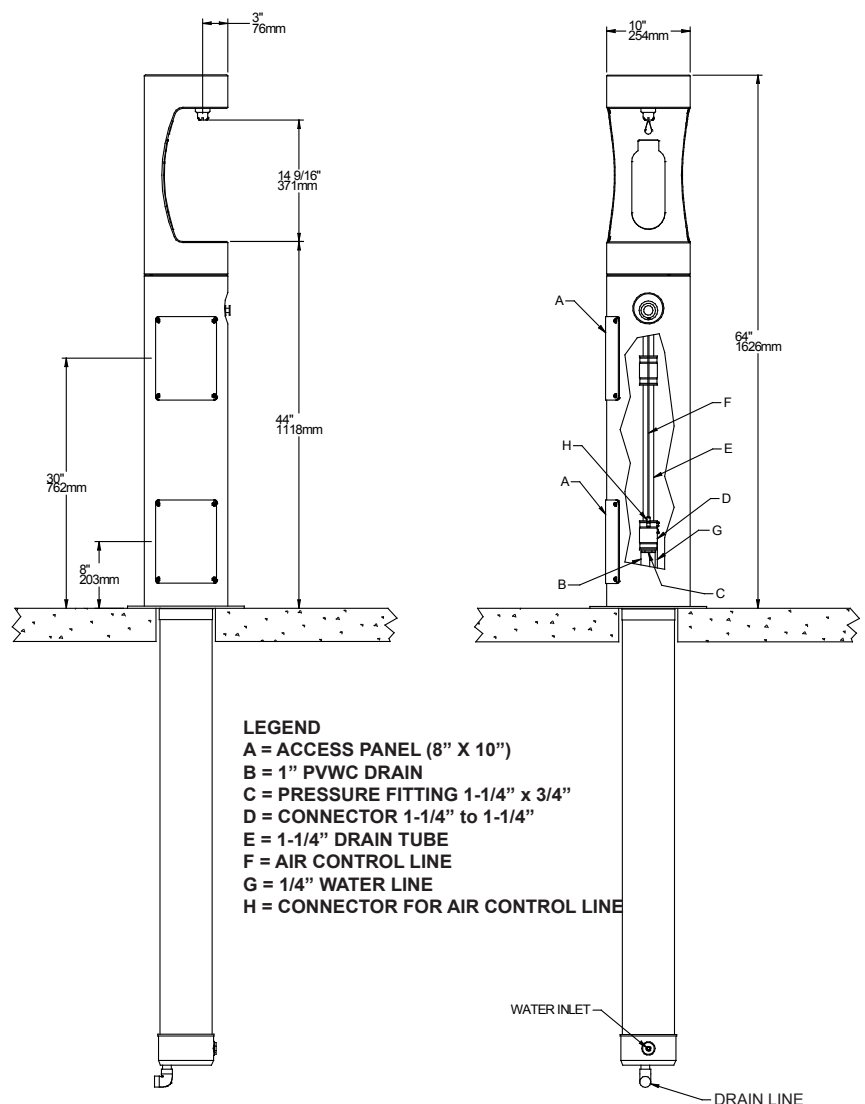

SITE PREPARATION DETAIL

