

# ELKAY® SPECIFICATIONS

## EZH2O® In-Wall Bottle Filling Station with with Single SwirlFlo® Refrigerated Fountain Model EZWS-SFGRN28K

RATED FOR INDOOR USE ONLY

### PRODUCT SPECIFICATION

In-wall bottle filling station with bi-level refrigerated oval fountain with two high-efficiency ECH8GRN chilling units. EZWS-SFGRN28K shall deliver 8 GPH of 50°F drinking water at 90°F ambient and 80°F inlet water. Bi-level stainless steel fountain with rounded edges and vandal-resistant pushbutton. Bottle filling unit shall be stainless steel construction with plastic ABS alcove. Sensor-activation with an auto 20-second shut-off timer. Shall include Green Ticker™ displaying count of plastic bottles saved from waste. Bottle filler shall provide 1.1 gpm flow rate with laminar flow to minimize splashing. Shall include integrated silver ion anti-microbial protection in key areas. Unit shall meet ADA guidelines. Unit shall be lead-free design which is certified to NSF/ANSI 61 and 372 and meets Federal and State low-lead requirements. Unit shall be certified to UL399 and CAN/CSA 22.2 No. 120.



### STANDARD FEATURES

- Fountains feature the Flexi-Guard® StreamSaver™ Safety Bubbler
- Stylish oval basin with pushbutton activation
- Features high-efficiency ECH8GRN chilling unit

#### Bottle Filler

- Sanitary, touchless activation with auto 20-second shut-off (Bottle Filler)
- Integrated Silver Ion Anti-microbial Protection in key areas
- Quick Fill Rate: 1.1 gpm
- Laminar Flow provides minimal splash
- Real Drain System eliminates standing water
- Visual User Interface display includes:
  - Innovative Green Ticker™ counts bottles saved from waste
- Includes lower hinged panel for easy access and servicing
- Features high-efficiency ECH8GRN chilling unit

### COOLING SYSTEM





- High-efficiency compressor: hermetically-sealed, reciprocating type, single phase. Sealed-in lifetime lubrication.
- Condenser: Fan cooled. Fan motor is permanently lubricated.
- Cooling Unit: Combination tube-tank type. Continuous copper tubing with stainless steel tank. Fully insulated with EPS foam which meets UL requirements for self-extinguishing material.
- Refrigerant Control: Refrigerant R134a is controlled by accurately calibrated capillary tube.
- Temperature Control: Enclosed adjustable thermostat is factory preset. Requires no adjustment other than for altitude requirements, Easily accessible by removing lower grille panel.

### CONSTRUCTION

- Stainless steel bottle filler construction with ABS plastic alcove
- Includes stainless steel ventilating louvered grille; (includes two chilling units).
- Furnished with MF200 and MFWS100 wall mounting boxes constructed of galvanized steel.
- Flexi-Guard® StreamSaver™ Safety Bubbler utilizes an infused anti-microbial pliable polyester elastomer to prevent accidental mouth injuries. Flexes on impact. Lower-flow water efficient water stream.

**Warranty:** 5 year limited warranty on the unit's refrigeration system. Electrical components and water system are warranted for 12 months from date of installation or 18 months from factory shipment, whichever date falls first.

### CAPACITIES CHART

CAPACITIES CHART									
Model	Voltage / Hertz	Chilling** Capacity	F.L. Amps	Rated Watts	Approx. Ship Wt.	ADA Compliant	UL399 and CAN/CSA 22.2 No. 120 Certified	ANSI/NSF 61 and 372 Certified	GreenSpec® Listed
EZWS-SFGRN28K	115V / 60 Hz	8 GPH	3.8	260	208	•	•	•	•

\*\*Based on 80°F inlet water & 90°F ambient air temp for 50°F chilled drinking water.

*This specification describes an Elkay product with design, quality and functional benefits to the user. When making a comparison of other producer's offerings, be certain these features are not overlooked.*

In keeping with our policy of continuing product improvement, Elkay reserves the right to change specification without notice. Please visit [elkay.com](http://elkay.com) for the most current version.

2222 Camden Court  
Oak Brook, IL 60523  
630-572-3192  
[elkay.com](http://elkay.com)

© 2014 Elkay  
SPEC14-77 (12/2014)

**EZH20® In-Wall Bottle Filling Station with  
with Single SwirlFlo® Refrigerated Fountain  
Model EZWS-SFGRN28K**

**ELKAY®  
ROUGH-IN DIMENSIONS**

RATED FOR INDOOR USE ONLY

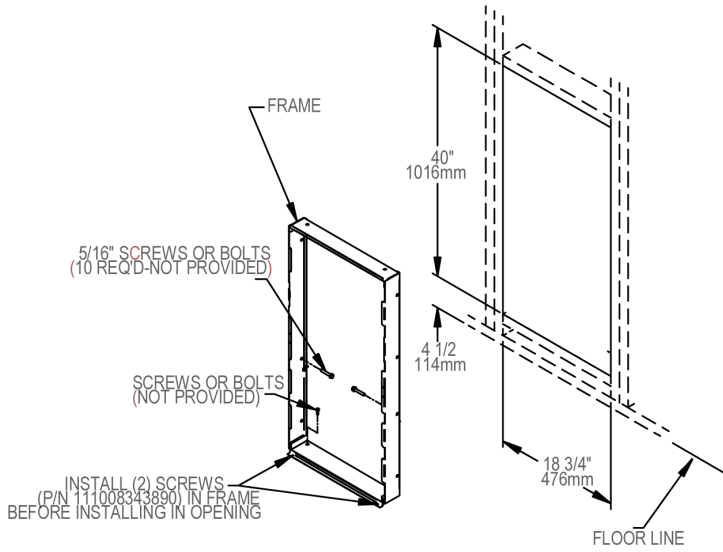

Job Name: \_\_\_\_\_

Model: \_\_\_\_\_ Qty. \_\_\_\_\_

Contact: \_\_\_\_\_

Approval Signature: \_\_\_\_\_

Notes:

DOUBLE STUD OR 3" (76mm)  
BETWEEN MOUNTING FRAME  
IF PLACED NEXT TO ANOTHER  
FOUNTAIN OR WALL

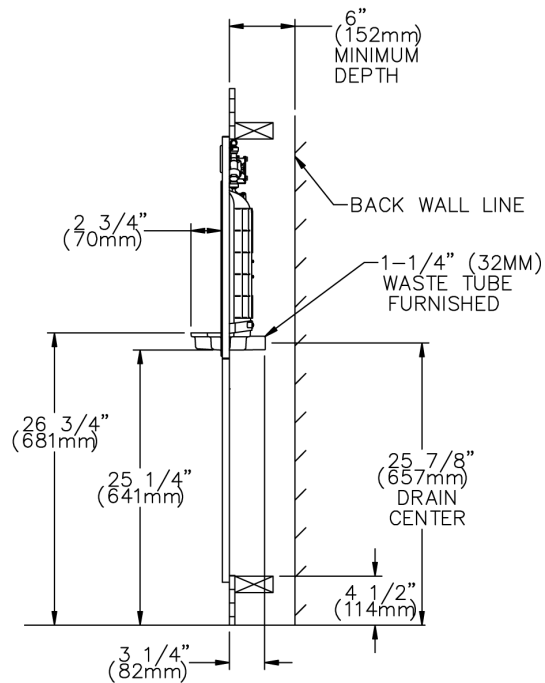
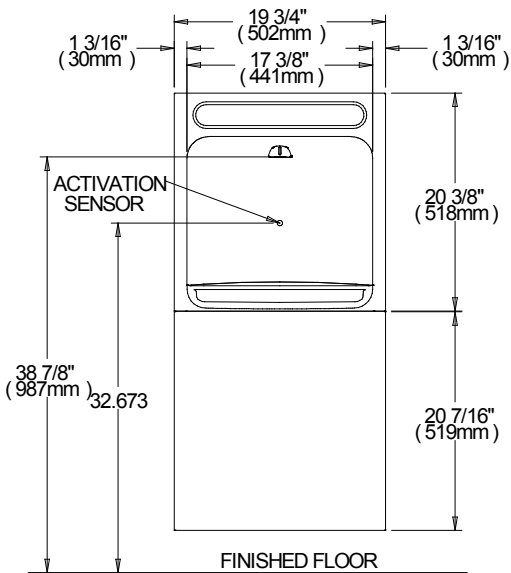
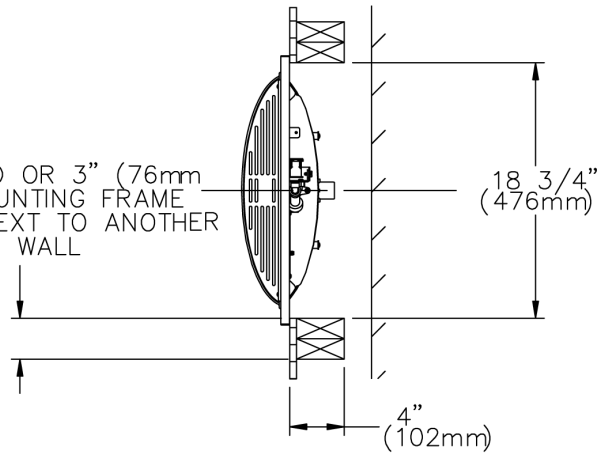

**EZH20® In-Wall Bottle Filling Station with  
Single SwirFlo® Refrigerated Fountain  
Model EZWS-SFGRN28K**

**ELKAY®  
ROUGH-IN DIMENSIONS**

RATED FOR INDOOR USE ONLY

**IMPORTANT!  
INSTALLER PLEASE NOTE:**

The grounding of electrical equipment such as telephone, computers, etc., to water lines is a common procedure. This grounding may be in the building or may occur away from the building. This grounding can cause electrical feedback into a water cooler, creating an electrolysis which causes a metallic taste or causes an increase in the metal content of the water. This condition is avoidable by using the proper materials as indicated below. The drain fittings which are provided by the installer should also be plastic to electrically isolate the cooler from the building plumbing system

**FOUNTAIN MOUNTING FRAME INSTRUCTIONS**

1. Cut a square rectangular wall opening 37-1/2"(953mm) W x 37-3/4"(959mm) H and 4-1/2"(114mm) above the floor line. These dimensions are required to obtain proper rim and bubbler heights for compliance with ANSI standard.
2. Reinforce the wall opening on all sides so that it will adequately support the water fountain. This reinforcement must support up to 150 lbs static load and provide a means for securing the frame assembly in place. NOTE: Building construction must allow for adequate air flow on both sides and top of remote chiller unit. Minimum of 4" (102mm) is required.
3. Install plumbing and electrical rough-ins. See Figure for location of the supply water inlet to chiller and for the location of the waste water outlet. A junction box for a (3) wire, 10 amp branch circuit is provided on the inside of the chiller. (Standard 115 Volts, 60 Hz and single phase)
4. Remove frame and related hardware from packaging. Release the two shelf rods by cutting cable ties. Install the frame squarely in wall opening with frame upright edges flush with the finished wall face. Place shelf inside frame and line up the (2) holes on each. Insert loose ends of rods into holes on sides of shelf. Using appropriately sized wood screws (not provided), fasten the shelf and frame to bottom of wall opening. Secure the frame sides and top to the wall using (10) 5/6" x 2" lag bolts or screws (not provided).

**NOTE:** Be sure that frame is squared in location. Do not use less than required screw quantity and size.

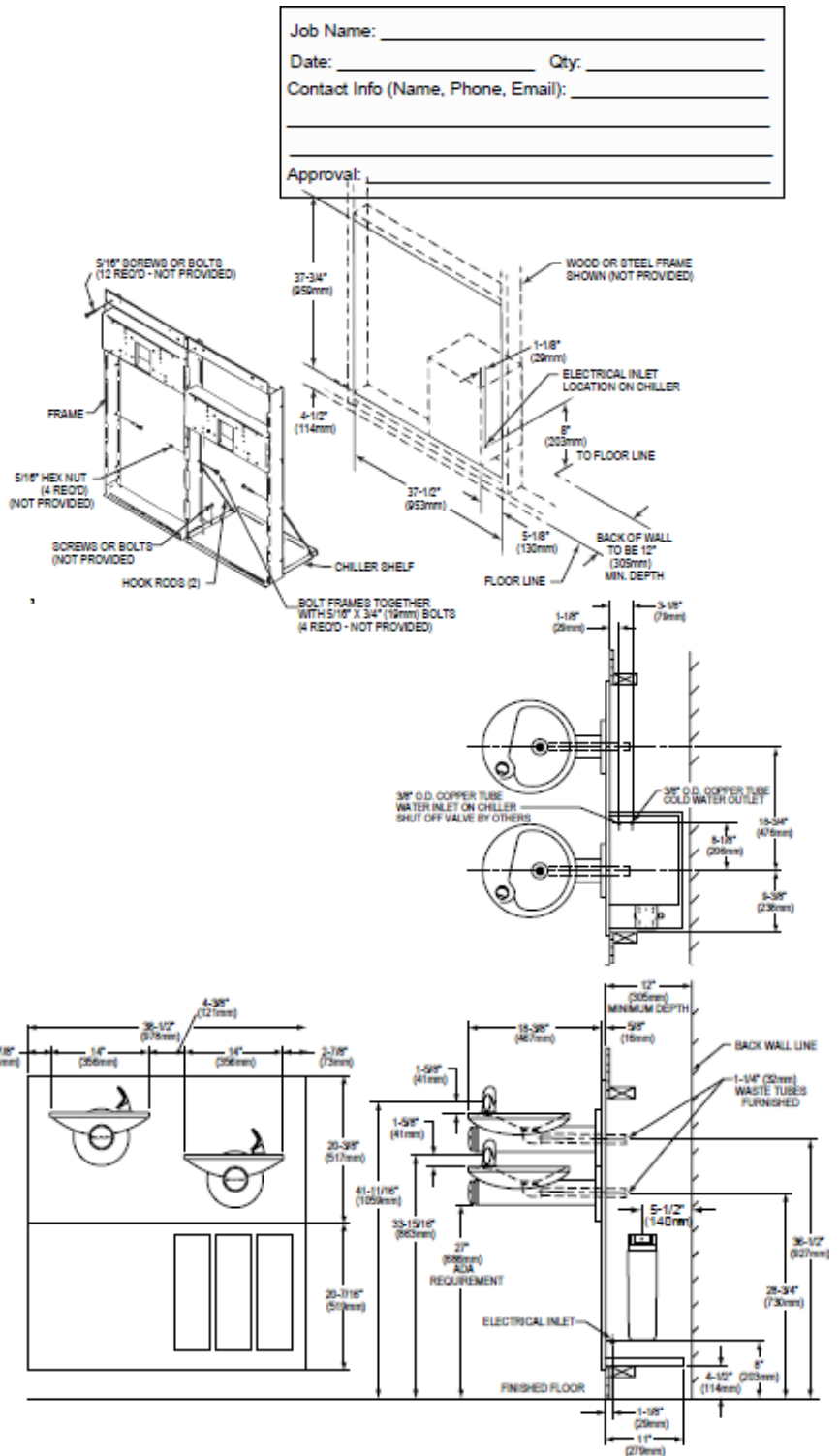

Job Name: \_\_\_\_\_  
 Date: \_\_\_\_\_ City: \_\_\_\_\_  
 Contact Info (Name, Phone, Email): \_\_\_\_\_  
 \_\_\_\_\_  
 Approval: \_\_\_\_\_