

# ELKAY® SPECIFICATIONS

## No Lead Drinking Fountain Soft Sides® Wall Mount – Fully Exposed Model EDF214WC (Shadow White)

### GENERAL

Wall mounted drinking fountain constructed of durable, non-porous composite gel coated material. Available in Shadow White color.

Contoured basin minimizes splashing and has LK142 push-button bubbler. Bottom cover plate included. Flow regulator provides constant stream from 20 to 105 psi water pressure.

### NO LEAD DESIGN

**THIS DRINKING FOUNTAIN COMPLIES WITH THE LEAD-FREE DEFINITION IN THE SAFE DRINKING WATER ACT OF 1986 AND LEAD CONTAMINATION CONTROL ACT OF 1988.**

Elkay Drinking Fountains are manufactured with a waterway system utilizing copper components and completely lead-free material. These waterways have no lead because all leaded materials, such as leaded brass, have been removed.

This fountain is certified by WQA to lead-free compliance including NSF/ANSI 61-ANNEX G, AB 1953.

### CONSTRUCTION

EDF214WC furnished complete LK142 pushbutton bubbler, low regulator (20 to 105 psi), and drain and trap assembly. Bottom cover plate included.

### ACCESSORIES

**MPW101** In-wall carrier mounting plate.

**ML100** Support columns for MPW101.

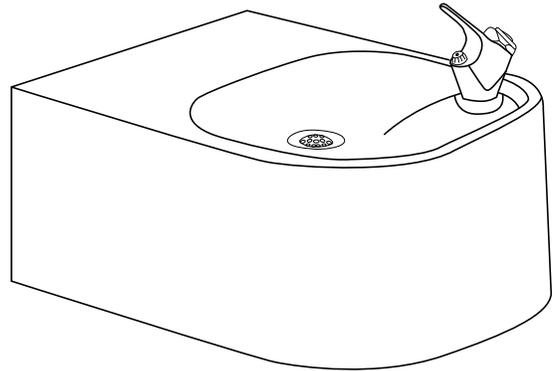

Model EDF214WC

### Care and Maintenance of Elkay Composite Fountains

The composite fountain provides an extremely durable, nonporous surface which resists staining. Care is very simple. Routine cleaning with a soft sponge or cloth, or with water or non-abrasive aerosol foam cleaner, is all that is normally needed to give many years of trouble free service. Cleaners left standing on the fountain surface can dull the surface finish. Be certain to rinse all cleaning agents completely and polish with a soft cloth.

Harsh abrasive cleaners are not required and should not be used.

Mild abrasives such as liquid automotive cleaning compound or baking soda paste will remove simple scratches and stains. Cigarette burns can normally be removed without noticeable effect.

To maintain or regain luster and make cleaning easier, periodic applications of automobile wax or like products will keep the finish looking like new.

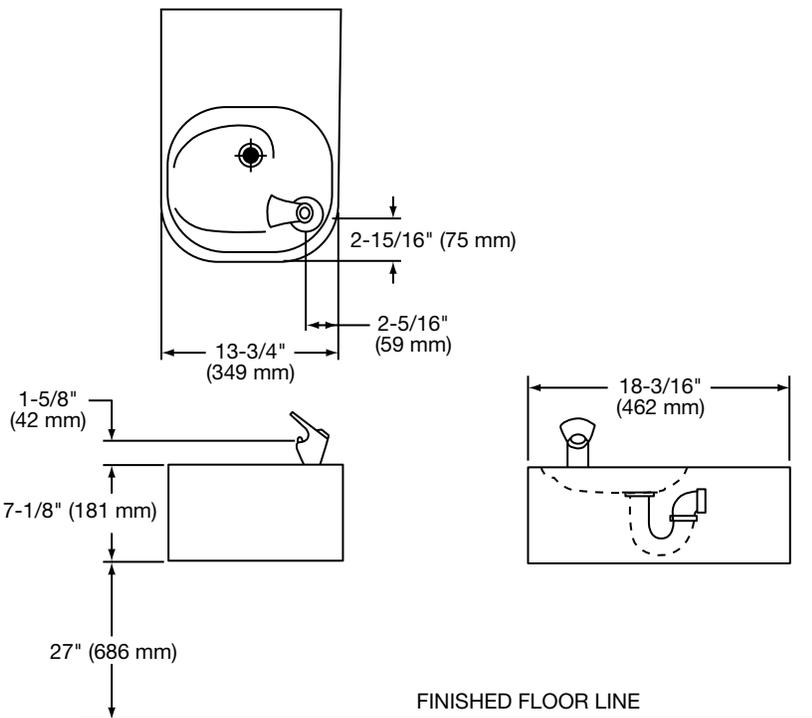

*In keeping with our policy of continuing product improvement, Elkay reserves the right to change product specifications without notice. Please visit [elkayusa.com](http://elkayusa.com) for most current version of Elkay product specification sheets.*

*This specification describes an Elkay product with design, quality and functional benefits to the user. When making a comparison of other producers' offerings, be certain these features are not overlooked.*

**Elkay**

[elkayusa.com](http://elkayusa.com)

2222 Camden Court  
Oak Brook, IL 60523

Printed in U.S.A.  
©2011 Elkay

(Rev. 4/11) 14-28D

**No Lead Drinking Fountain Soft Sides®**  
**Wall Mount – Fully Exposed**  
**Model EDF214WC (Shadow White)**

**ELKAY®**  
**ROUGH-IN DIMENSIONS**

**INSTALLER NOTE**

THIS DRINKING FOUNTAIN IS FURNISHED WITH A BUBBLER AND VALVE INCLUDING ALL CONNECTING FITTINGS WHICH ARE MANUFACTURED OF COMPLETELY LEAD FREE MATERIAL. SHUT OFF VALVE (NOT FURNISHED) TO ACCEPT 3/8" O.D. UNPLATED COPPER TUBE.

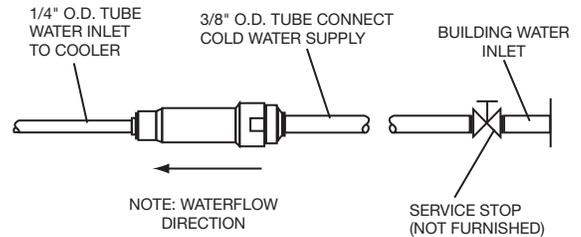

**OPERATION OF QUICK CONNECT FITTINGS**

