

# ELKAY®

## SPECIFICATIONS

### EZH2O® Bottle Filling Station Mechanical Activation, Filtered Surface Mount Model LMASMB

#### PRODUCT SPECIFICATION

*Rated for Indoor Use Only*

Surface Mount bottle filling station designed for installations without the need for electricity. Shall include battery operated Green Ticker™ displaying count of 20 oz. plastic bottles saved from waste. Bottle filler shall provide 0.5 gpm flow rate filtered, with laminar flow to minimize splashing. Shall include integrated silver ion antimicrobial protection in key areas. Shall include 500-gallon cyst and lead reduction filter, certified to NSF/ANSI 42 and 53, with visual monitor to indicate when replacement is necessary. Unit shall meet ADA guidelines. Unit shall be a lead-free design which is certified to NSF/ANSI 61 and 372 and meets Federal and State low-lead requirements.

#### STANDARD FEATURES

- Complete mechanical water activation and function  
No electrical connection required
- Quick Fill Rate of 0.5 gallon per minute
- Integrated Silver Ion Anti-microbial Protection in key areas
- Laminar Flow provides minimal splash
- 500-gallon Cyst and Lead Reduction Filter, included, certified to NSF/ANSI 42 & 53 (Lead, Class 1 Particulate, Chlorine Taste & Odor)
- Real Drain System eliminates standing water
- No bubbler required
- Battery operated visual user interface display includes:
  - Innovative Green Ticker™ counts 20 oz. bottles saved from waste
  - LED Visual Filter Monitor shows when replacement is necessary
  - LCD display shows when batteries need replacing.
- Optional remote chiller can be installed within 15 feet of unit to deliver chilled drinking water

#### CONSTRUCTION

- Stainless steel bottle filler wrapper with ABS plastic alcove.
- Includes robust hanging bracket for surface mount.

#### CAPACITIES CHART

Model	Voltage	Chilling Capacity	Approx Ship Weight
LMASMB	4.5 VDC (3 AA batteries)	N/A unless connected to chiller	24 lbs.

*The above ratings apply only to the LMASMB unit.  
Ratings for the chiller not included.*

**Warranty:** Electrical components (excl. batteries) and water system is warranted for 12 months from date of installation or 18 months from factory shipment, whichever date falls first.



Model LMASMB

#### REPLACEMENT FILTER:

- 56192C (single)

#### CERTIFICATIONS / STANDARDS

- ADA Compliant
- NSF/ANSI 61 and 372 Certified
- Filter is NSF/ANSI 42 and 53 Certified



C USA



This specification describes an Elkay product with design, quality and functional benefits to the user. When making a comparison of other producer's offerings, be certain these features are not overlooked.

# EZH2O® Bottle Filling Station

## Mechanical Activation, Filtered

### Surface Mount Model LMASMB

# ELKAY®

## ROUGH-IN DIMENSIONS

### IMPORTANT!

#### INSTALLATION NOTES:

- Ensure wall is structurally sound to bear the loads imparted by the Surface Mount Bottle Filler.

#### ELECTRICAL

*Rated for Indoor Use Only*

**EZH2O equipped with (3) AA batteries for Green Ticker™ operation.**

### ADA Stand Alone Mounting

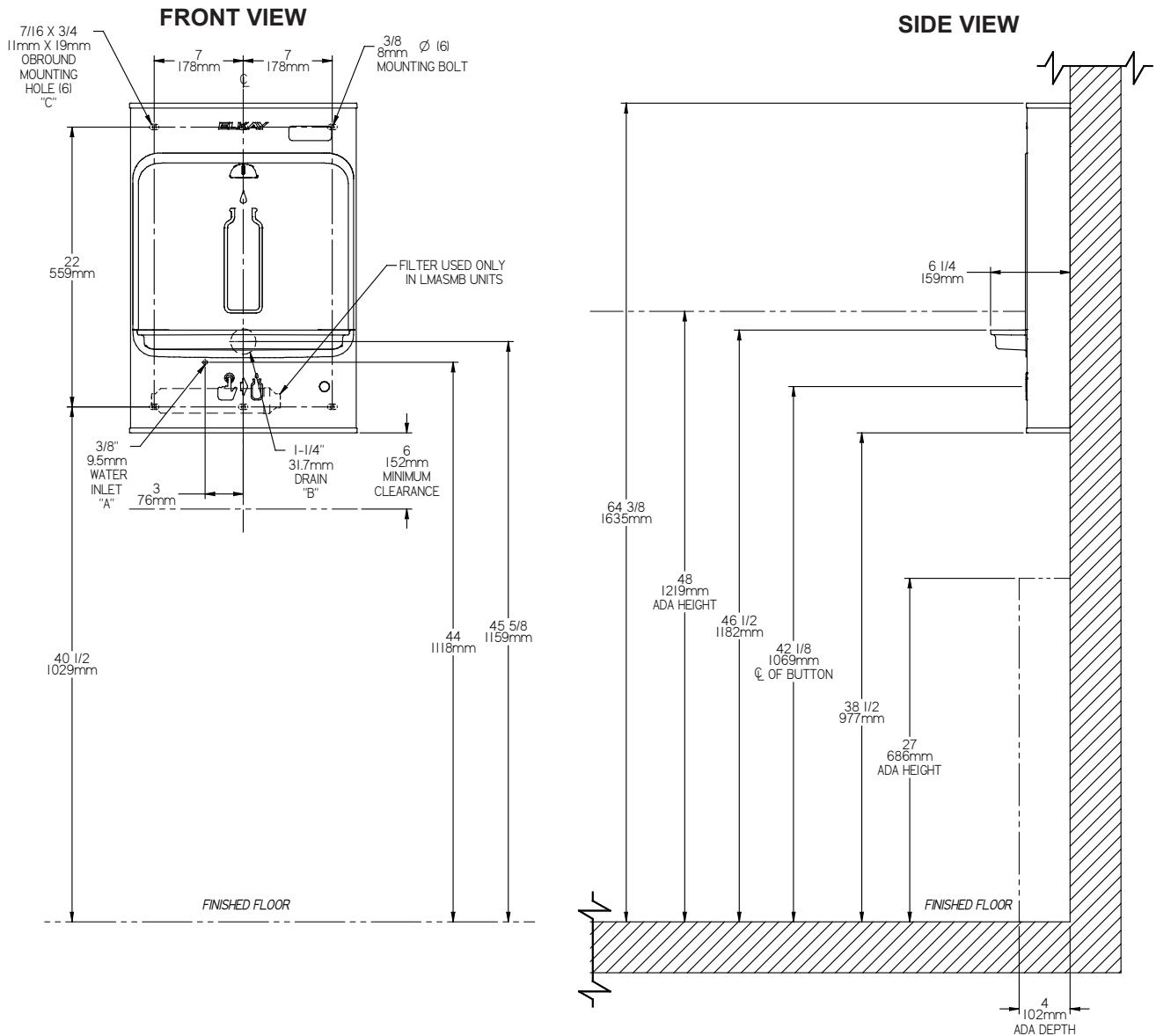

#### LEGEND

A = RE  
1/2

SERVICE STOP VALVE NOT FURNISHED.

B = RECOMMENDED WASTE LOCATION.  
WASTE SHOWN IN WALL BUT MAY BE BEHIND WALL.  
OUTLET 1-1/4" O.D. (TRAP NOT FURNISHED)

C = 7/16" X 3/4" OBRROUND MOUNTING HOLES FOR FASTENING  
BACKPLATE TO WALL.

Job Name:	_____
Model:	_____ Qty. _____
Contact:	_____
Approval Signature:	_____
Notes:	_____

**EZH20® Bottle Filling Station**  
**Mechanical Activation, Filtered**  
**Surface Mount Model LMASMB**

**ELKAY®**  
**ROUGH-IN DIMENSIONS**

**IMPORTANT!**

**INSTALLATION NOTES:**

- Ensure wall is structurally sound to bear the loads imparted by the Surface Mount Bottle Filler.

**ELECTRICAL**

*Rated for Indoor Use Only*

**EZH20 equipped with (3) AA batteries for Green Ticker™ operation.**

**ADA Above Cooler Mounting**

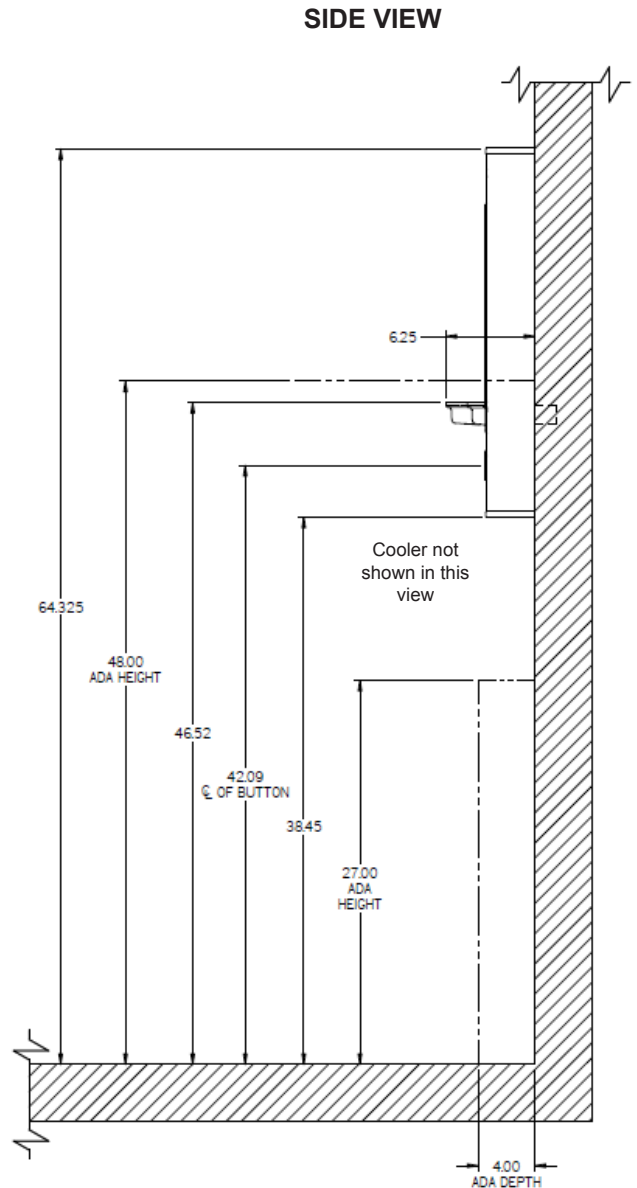
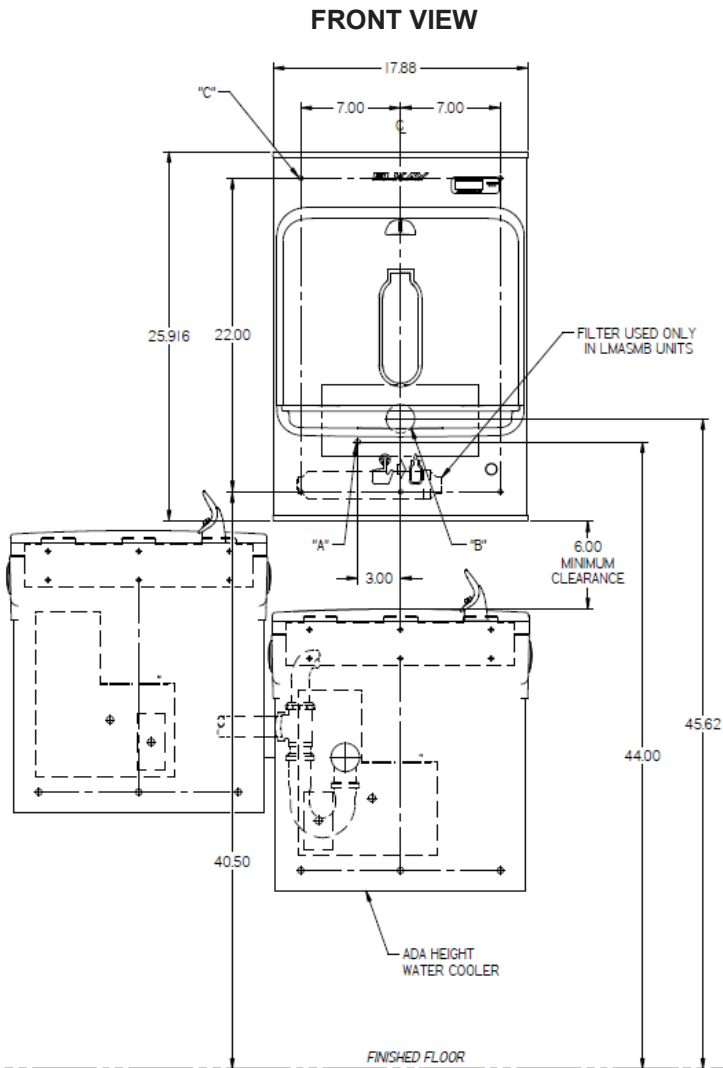

REDUCE HEIGHT BY 3 INCHES FOR INSTALLATION ABOVE CHILDRENS ADA COOLER

**LEGEND:**

- A = RECOMMENDED WATER SUPPLY LOCATION;**  
 1/2" IPS MAXIMUM PIPE SIZE.  
 SERVICE STOP VALVE NOT FURNISHED.
- B = RECOMMENDED WASTE LOCATION.**  
 WASTE SHOWN IN WALL BUT MAY BE BEHIND WALL.  
 OUTLET 1-1/4" O.D. (TRAP NOT FURNISHED)
- C = 7/16" X 3/4" OBOUND MOUNTING HOLES FOR FASTENING**  
 BACKPLATE TO WALL.

Job Name: \_\_\_\_\_  
 Model: \_\_\_\_\_ Qty. \_\_\_\_\_  
 Contact: \_\_\_\_\_  
 Approval Signature: \_\_\_\_\_  
 Notes: \_\_\_\_\_