

# Installation Sheet

## DIRECT BURY FOUNTAIN ADAPTER

For Use On 4400, 4410, 4420, & 4430 Model Fountains

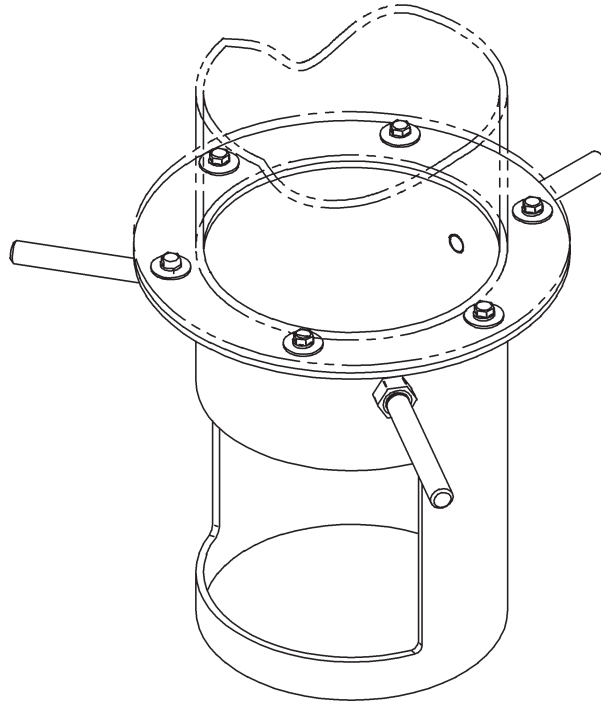

### Installer

To assure you install this model easily and correctly, PLEASE READ THESE SIMPLE INSTRUCTIONS BEFORE STARTING THE INSTALLATION. CHECK YOUR INSTALLATION FOR COMPLIANCE WITH PLUMBING, ELECTRICAL AND OTHER APPLICABLE CODES.

### IMPORTANT

ALL SERVICE TO BE PERFORMED BY AN AUTHORIZED SERVICE PERSON

### IMPORTANT! INSTALLER PLEASE NOTE.

THE GROUNDING OF ELECTRICAL EQUIPMENT SUCH AS TELEPHONE, COMPUTERS, ETC. TO WATER LINES IS A COMMON PROCEDURE. THIS GROUNDING MAY BE IN THE BUILDING OR MAY OCCUR AWAY FROM THE BUILDING. THIS GROUNDING CAN CAUSE ELECTRICAL FEEDBACK INTO A FOUNTAIN, CREATING AN ELECTROLYSIS WHICH CAUSES A METALLIC TASTE OR AN INCREASE IN THE METAL CONTENT OF THE WATER. THIS CONDITION IS AVOIDABLE BY USING THE PROPER MATERIALS AS INDICATED. ANY DRAIN FITTINGS PROVIDED BY THE INSTALLER SHOULD BE MADE OF PLASTIC TO ELECTRICALLY ISOLATE THE FOUNTAIN FROM THE BUILDING PLUMBING SYSTEM.

## 4400 Direct Bury Fountain Adapter

### PARTS LIST

ITEM NO.	PART NO.	DESCRIPTION
1	45835C	Adapter - Direct Bury Fountain
2	75617C	ROD -3/4" DIA (UNPAINTED)
3	75616C	Nut - 3/4" - 10UNC-2B Hex.
4	70204C	Bolt - 3/8"-16UNC-2A Hex. Hd.
5	75611C	Washer - 3/8" Lock
6	70421C	Washer - 3/8" Plain

### INSTALLATION INSTRUCTIONS

1. Thread Nuts (Item 3) onto Rods (Item 2)(one Nut per Rod).
2. Thread Rods into Adapter Cylinder (Item 1) and tighten Nuts against Cylinder Securely.
3. Place Washers (Item 6) on Bolts (Item 4)(one Washer per Bolt), Assemble Bolts into Adapter Flange. **Thread Bolts all the way in.**
4. Secure Adapter into Concrete Forms as per Standard Practice and as Shown Below. Be sure to Align Adapter for proper location of **Water Inlet Line, Drain Line,** and required **Fountain Alignment.**
5. After Sufficient Cure of Concrete, remove Flange Bolts and Washers.
6. Mount Fountain Assembly per Instructions Supplied with Fountain and Items 4, 5, & 6 (See Below).

