



ELICA'S EXCLUSIVE PLUS FEATURES



HUSH SYSTEM



LED REPLACEABLE



SEAMLESS LOOK



GREASE COLLECTORS



PERFORMANCE





HEAT GUARD

Trento provides professional grade performance, while being discreetly mounted inside the cabinetry. It is available with a 600 CFM or 1200 CFM blower for extraordinary ventilating power. Plus the All-In-One design avoids the need to purchase a stainless liner. Hidden metallic in/out knob controls operate the 4-speed blower and LED lighting.

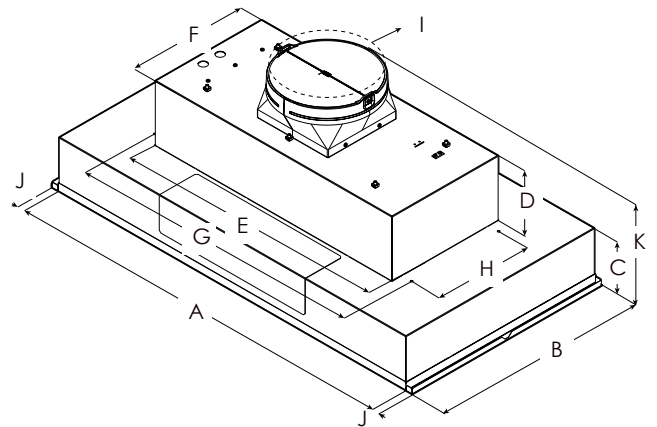
A cleaner kitchen is ensured by Elica's patented angled baffle filters, which capture a higher percentage of contaminants and hold larger volumes of grease than traditional baffle filters.





 $\geq 24''$ $\geq 30''$

MOUNTING
HEIGHT
RANGE

	ETR628SS	ETR634SS ETR134S1	ETR146SS
A	28 1/2" (87.5 cm)	34 1/2" (87.5 cm)	46 1/2" (118.5 cm)
B	18" (45.7 cm)		
C	5 7/16" (13.8 cm)		
D	6 1/2" (16.4 cm)		
E	22 3/64" (56 cm)	27 5/16" (70 cm)	
F	12 7/16" (31.6 cm)		
G	24 21/64" (62 cm)	29 13/16" (75.7 cm)	
H	10 1/8" (25.7 cm)		
I	10" (25.4 cm)		
J	3/4" (1.9 cm)		
K	16 11/16" (42.4 cm)		

SPECIFICATIONS

Width:	28" Unit	34" Unit	46" Unit
Model:	ETR628SS	ETR634SS* ETR134S1**	ETR146SS
Dimensions:	28 1/2"W x 18"D x 11 7/8"H	34 1/2"W x 18"D x 11 7/8"H	46 1/2"W x 18"D x 11 7/8"H
Blower Type(internal):**	600 CFM (4-speed)	600 CFM* / 1200 CFM**	1200 CFM (4-speed)
Noise (sones):**	7 Sones	7 Sones* 8.5 Sones**	8.5 Sones
Finish:	Stainless Steel		
Controls:	Fully retractable rotating knobs with blue backlighting		
Illumination:	2 LED, 6.5 W, 3000 K, 540 Lumen/Lamp		
Filter Type:	Dishwasher-Safe, Professional Stainless Steel Baffle filter 2 for 34" & 3 for 46"		
Duct Transition:	10" Round with BackDraft Damper (top only)		
Installation Type:	Ducted or recirculating with kit		
Electrical:	120V - 60 Hz, 490 W	120V - 60 Hz, 490 W* 120V - 60 Hz, 913 W**	120V - 60 Hz, 926 W
KITS:			
1200 CFM External Blower Kit:	KITO153054		
1200 CFM In-line Blower Kit:	KITO154387		
In-line Blower Shell Kit:	KITO179549 (for use with 1200 CFM blowers only)		
External Blower Shell Kit:	KITO179547 (for use with 1200 CFM blowers only)		
Electronic CFM Reduction Bypass Kit:	KITO185752 (for 600 CFM Blower), KITO185099(for 1200 CFM Blower)		
Recirculation Kit:	KITO192765 (4 round carbon filters) + KITO192763 (10" round deflector)		
WARRANTY:***	Two (2) Years Parts & In-Home Labor. Earn an additional One (1) Year of Parts & In-Home Labor by registering on elica.com.		

PLUS FEATURES

- 

HUSH SYSTEM - An exclusive sound deadening technology that effectively reduces sound levels by over 35%.
- 

SEAMLESS CRAFTSMANSHIP - Heavy gauge stainless steel "Seamless" construction that delivers refined elegance.
- 

HEAT GUARD - Senses extreme temperatures (>158 °F) and automatically adjusts the blower speed to HIGH.
- 

PROFESSIONAL PERFORMANCE - Special features and high performances for models with aspiration capacity between 600 and 1200 CFM's.
- 

STAINLESS STEEL BAFFLE FILTERS WITH GREASE COLLECTORS - Designed for high airflow cooking, the "S" shape design traps high volumes of grease.



Model	Certified Ratings	High Speed	Working Speed	Duct Size
ETR146SS ETR134S1	CFM Sones	860 12.5	320 2	10" (Vertical) 10" (Vertical)
ETR634SS ETR628SS	CFM Sones	500 9.5	180 2	10" (Vertical) 10" (Vertical)

* The product images shown are for illustration purposes only and may not be an exact representation of the product.

** Blower performance indicates the performance of the blower by itself. Performance claims are not AHAM certified but were established in accordance with HVI Standardized test procedure. For Certified Ratings, please refer to AHAM Certified Product Directory. Electric Ratings are declared according to UL.

*** For valid warranty extension, register within 3 months from purchase. For USA & Canada Users Only.