

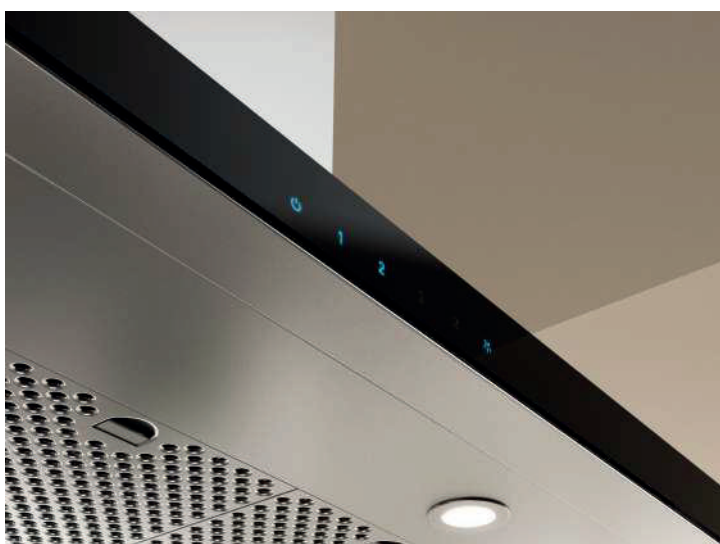

- 
CFM REDUCTION
- 
DIM LIGHT
- 
TOUCH CONTROL
- 
HUSH SYSTEM
- 
TOP PERFORMANCE
- 
LED LIGHT

ELICA'S EXCLUSIVE PLUS FEATURES

With a minimalist design but a strong stainless steel construction, Maggiore is in tune with avant-garde appliances where clear and architectural lines take precedence. Maggiore has a powerful 600 CFM blower, LED dimmable lights, stainless steel microhole filters and high-tech glass touch controls that deliver convenience and safety. Maggiore was designed for standard ducted installation, but with also can be installed using the Recirculating Kit, available as an accessory.

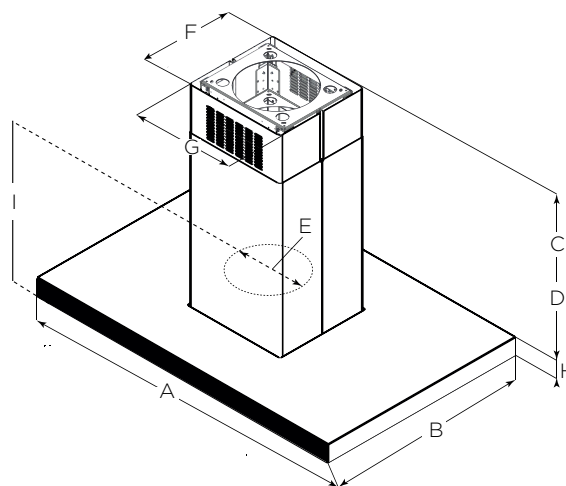

	EMG636S1	EMG642S1
A	36" (91.4 cm)	42" (106.7cm)
B	27 1/8" (68.9 cm)	
C*	Min: 29 13/16 (75.72cm) Max: 50 1/8 (127.32cm)	
D**	Min: 45" (114.5 cm) Max: 50 1/8 (127.32 cm)	
E	6" (15.9 cm)	
F	12" (30.4cm)	
G	13" (33.24cm)	
H	2 3/8" (6.03cm)	
I	15 15/16" (40.4cm)	

* Ductless (Recirculating) version
** Ducted version

Width:	36" Unit	42" Unit
Model:	EMG636S1	EMG642S1
Dimensions:	36" W x 27 1/8" D x Min: 29 13/16" Max: 50 1/8" H 42" W x 27 1/8" D x Min: 29 13/16" Max: 50 1/8" H	
Blower Type(internal):**	600 CFM(3-speed + boost)	
Noise (sones):**	6.8 Sones	
Finish:	Stainless Steel with black tempered glass	
Controls:	Capacitive touch (Glass)	
Illumination:	4 Premium Dimmable LED lights, 2.1 W, 4000 K	
Grease Filter:	Dishwasher-Safe, Stainless Steel Microhole Filter	
Duct Transition:	Top Round 6"	
Installation Type:	Ducted or Recirculating (Kit sold separately)	
Telescopic Chimney:	Can reach ceiling heights of min 7'6", max 9' 9" (ducted) & min 7'6", max 10'2" (recirculating)	
Electrical:	120V - 60 Hz, 426 W	
KITS:		
Recirculating Kit	KIT02665 (Contains 6"/8" deflector & 2 carbon filters)	
Chimney Extension Kit:	KIT0100317 (Reaches ceiling heights of 8'9"-12'8"(ducted), 9'2"-12'9" (recirculating)	
Charcoal Filter:	KIT02667	
WARRANTY:***	Two (2) Years Parts & In-Home Labor. Earn an additional One (1) Year of Parts & In-Home Labor by registering on elica.com.	

PLUS FEATURES



CFM REDUCTION - CFM Reduction System (CRS), is an exclusive feature to Elica hoods, which enables the user to reduce the maximum blower CFM, to meet local code requirements.



DIM LIGHT - The Dimmer allows you to adjust the brightness of the light as you wish. With Elica, lighting is customized in a discreet, personal and practical way, in order to contribute in creating the perfect kitchen atmosphere.



ELECTRONIC TOUCH CONTROLS - Enjoy the modern design and convenience of multi-function electronic touch controls, which are discreetly hidden behind sleek black glass, and will illuminate a soft blue when activated.



HUSH SYSTEM - An exclusive sound deadening technology that effectively reduces sound levels by over 35%



TOP PERFORMANCE - Excellent performance for models equipped with this plus. High fume capturing capacity with and average aspiration range of 600 CFM's and a noise level between 60-65 db (A) at maximum speed (reference point varies based on the hood category).



LED LIGHT - LED lighting is undoubtedly the smartest solution in terms of energy saving. Expected life is over 20,000 hours, and should last the full life of the hood.



Certified Ratings	High Speed	Working Speed	Duct Size
CFM	400	170	6" vertical
Sones	7.5	1.5	6" vertical

* The product images shown are for illustration purposes only and may not be an exact representation of the product.

** Blower performance indicates the performance of the blower by itself. Performance claims are not AHAM certified but were established in accordance with HVI Standardized test procedure. For Certified Ratings, please refer to AHAM Certified Product Directory. Electric Ratings are declared according to UL.

*** For valid warranty extension, register within 3 months from purchase. For USA & Canada Users Only.