

ICONIC SERIES
ILLUSION



TOP PERFORMANCE



REMOTE CONTROL



TUNE WHITE



SUPER EASY INSTALLATION



SPECIAL MATERIAL



DIM LIGHT



TOTAL INTEGRATION



CLEAN FILTER ALARM



REPLACE FILTER ALARM

ELICA'S EXCLUSIVE PLUS FEATURES

FIRST PANEL-READY CEILING HOOD IN THE MARKET, perfectly fitting the ceiling texture of the living space, disappearing like a true Illusion. Also naturally saves valuable kitchen space and frees the area of inconvenient obstructions cleverly hiding a powerful extraction system that guarantees always clean air in the living space. Combining discreet shapes and high performance, Illusion has been created for consumers who ask for an essential and bespoke style without compromises on functionality.

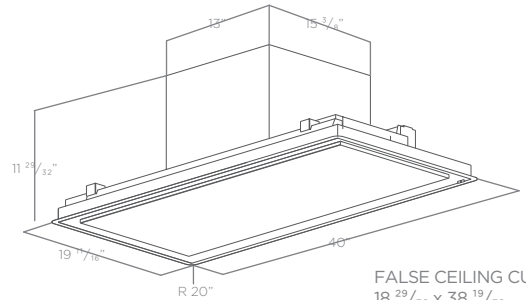

FALSE CEILING CUT:
18 ²⁹/₃₂ X 38 ¹⁹/₃₂
*Can be installed up to 10 feet.

1, 2, 3, 4, 5, 6
Gypsum board
fixing points

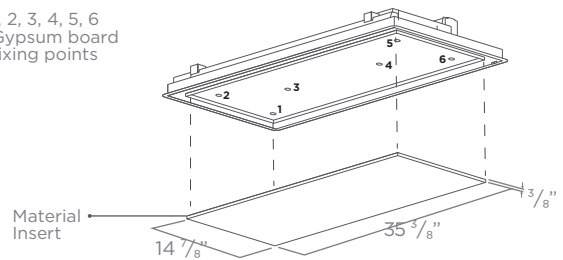

Material Insert

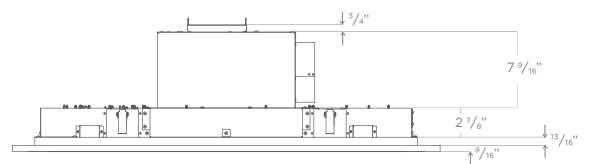

***FLEXIBLE INSTALL**

Blower offers 5 possible exit directions, allowing you to decide on which side to attach the air outlet duct.

SPECIFICATIONS

Width:	40" UNIT	40" UNIT
Model:	EIL640WH	EIL640DW
Dimensions:	40" W x 19 17/25" D	
Blower type (internal):	600 CFM (3-speed + boost)	
Noise (sones):	6.8 Sones	
Finish:	Metal White with white frame	Naked panel (stainless steel) + stainless steel frame
Controls:	Remote Control	
Illumination:	2 Strip LED Lights, 14 W	
Grease Filter:	Dishwasher-Safe, Anodized Aluminum, Mesh Filter + Perimeter Aspiration	
Installation type:	Ducted or Recirculating (Kit sold separately)	
Duct transition:	Round 6" (multi directional)	
Installment Height:	Can reach ceiling heights up to 10'0"	
Electrical:	120v 60 Hz, 578 W	
KITS:		
Recirculating Kit:	KIT0167875 (Contains 3 long life carbon filters)	
White remote control:	KIT0121468	
Black remote control:	KIT0121469	
WARRANTY:**	Two (2) Years Parts & In-Home Labor. Earn an additional One (1) Year of Parts & In-Home Labor by registering on elica.com	

PLUS FEATURES

- 

DIM-LIGHT - The Dimmer allows you to adjust the brightness of the light as you wish. With Elica, lighting is customized in a discreet, personal and practical way, in order to contribute in creating the perfect kitchen atmosphere
- 

TUNE WHITE - The ability to choose the preferred shade of white always creates the right atmosphere. The Kelvin degrees regulation starts from a very warm tone, 2400°K, to experience intimate and convivial moments, up to a cold colour, 5000°K.
- 

REMOTE CONTROL - Elica's ADA compliant Remote Control, provides added convenience to the typical user, as well as, full function access for those with limited mobility.
- 

SUPER EASY INSTALLATION - With the exclusive Elica system, installation can be done in total safety in just a few steps, safeguarding the look of the product and the space in which it is positioned.
- 

REPLACE FILTER ALARM - When activated, your hood will emit a "beep" signal let you know when is time to replace the carbon filters. See instructions manual to activate feature.
- 

TOP PERFORMANCE - Excellent performance for models equipped with this plus. High fume capturing capacity with an average aspiration range of 600 CFM's. with low noise levels, 1.2 - 1.7 sones at working speed.
- 

LONG LIFE FILTER - One of a kind odour filter, capable of regenerating itself and of lasting up to 3 years. To maintain these characteristics, the filter only requires simple maintenance: wash every 2 or 3 months with hot water and mild soap (also in dishwasher at 65 degrees) and dry in the oven for ten minutes at 100 degrees.
- 

TOTAL INTEGRATION - The Total Integration products have been designed to be seamlessly integrated into the kitchen whilst maintaining harmony with the surroundings.
- 

CLEAN FILTER ALARM - When activated, your hood will emit a "beep" signal to let you know when is time to clean your filters. For some models, an intermittent light will remain active until cleaning filter action is completed. See instructions manual to activate feature.



Certified Ratings	High Speed	Working Speed	Duct Size
CFM	450	190	6" (vertical)
Sones	7	1.5	6" (vertical)

* The product images shown are for illustration purposes only and may not be an exact representation of the product.

** Blower performance indicates the performance of the blower by itself. Performance claims are not AHAM certified but were established in accordance with HVI Standardized test procedure. For Certified Ratings, please refer to AHAM Certified Product Directory. Electric Ratings are declared according to UL.

*** For valid warranty extension, register within 3 months from purchase. For USA & Canada Users Only.