

NIKOLA TESLA SWITCH



ELICA'S EXCLUSIVE PLUS FEATURES

Extremely clean lines give life to a truly exclusive appliance, the NikolaTesla Switch, a concentrate of design and technology through which Elica has revolutionized the daily cooking experience.

A return to the origins with a simple induction cooktop, featuring continuous surfaces and a display that becomes completely invisible in stand-by mode. The extraction area is cleverly hidden by a black glass and steel disk, characterizing the product without clashing with the other elements.



-  **STOP & GO** - If you are interrupted while cooking, with just a single movement, pressing the Stop & Go button, you can switch off all the cooking zones and walk away with complete confidence and safety.
-  **DELAY SWITCH OFF** - A smart timer feature allows you to set the automatic switch-off of the product after a predetermined time. Delayed shutdown may be used in order to leave the hood on even after cooking, so as to fully remove stubborn odors and residual humidity.
-  **TIMER** - Set the cooking time and start the countdown. At the end, the cooking area will be automatically switched off and a beep will sound. You can set independent timers on more than one area at the same time.
-  **TEMPERATURE MANAGER** - The cooktop can be used with two different standard programs (107° F & 158° F) to always ensure perfect cooking.
-  **POT DETECTOR** - The hob automatically detects the presence of the pot in the cooking area and provides heat only when it is correctly positioned.
-  **TOUCH CONTROLS** - Multifunction electronic touch control behind sleek black glass and illuminate red when activated.
-  **AIRMATIC** - intelligent sensor system detects the quantity - but above all the quality - of the fumes produced by the type of cooking and sets the most suitable aspiration power automatically.
-  **CHILD LOCK** - This avoids that the cooking or extraction areas are not accidentally switched on. The function can be enabled when the product is switched on but the cooking areas and extraction are switched off.
-  **TOTAL INTEGRATION** - The Total Integration products have been designed to be seamlessly integrated into the kitchen whilst maintaining harmony with the surroundings.
-  **WARMING MODE** - Designed for low temperature cooking, ideal for heating liquids without worrying about overheating. Keeps prepared food warm, while other foods are still cooking.
-  **BRIDGE ZONES** - Avoid heat to be progressively dispersed when using longer or larger pans, by joining two cooking areas into one single larger area. With the same power, uniform, and constant temperature.
-  **EASY MAINTENANCE** - All the components, such as the grease and odor filters, can be easily accessed and removed so they can be washed or rapidly replaced. Making it a low-maintenance product.
-  **ODOR FILTERS** - Elica Ceramic filters purify the air, its technology is able to achieve a filtering threshold of 82% against the market average of 60%.

NIKOLA TESLA SWITCH

SPECIFICATIONS



Width:	36" UNIT
Model:	ENS436BL
Dimensions:	36 1/2" x 20 1/4" x 8 1/4"
Cooking Zones:	4 Cooking Zones (2,1 - 3,7kW) - 7,1 x 7,9 inches
Heating Type:	Induction
Heating Level:	10 Levels (9 + Boost, see details in chart below)
Ventilation:	4 speed (3 + boost)
Blower Type (internal):	400 CFM (Booster)
Noise (sones) :	5.9 Sones
Grease filter :	6 Layer Dishwasher-safe Anodized Aluminum Mesh
Recirculating filter :	3 Ceramic Carbon Filters Included
Finish:	Tempered, Ultra Deep Black Ceramic Glass
Controls:	Electronic Glass Touch & Slide w/red illumination
Installation Type:	Ducted Out or Recirculating
Duct Transition:	3 1/4 x 10" rectangular
Electrical:	208 - 240 V - 60 Hz 440 Watts at 3.3 Amps 240V - 7.8kW at 32.5 Amps 208V - 7.1kW at 34.1 Amps
WARRANTY:***	Three (3) Years Parts & In-Home Labor.



Cooking Level	Power (W)
Level 1	63 W
Level 2	105 W
Level 3	168 W
Level 4	252 W
Level 5	378 W
Level 6	588 W
Level 7	882 W
Level 8	1344 W
Level 9	2100 W
Booster	3700 W

Glass Specifications**	
Material	Glass-ceramic cooking panel
Appearance	Deep - black color
Thickness	4mm
Color in reflexion	Black
Color in transmission	Amber
Surface structure	Though crystal smooth scratch and stain-resistant

AWARDS



reddot design award winner

*The product images shown are for illustration purposes only and may not be an exact representation of the product.

**The glass featured in NikolaTesla models is environmentally friendly, manufactured without arsenic or antimony metals.

*** 3rd year awarded after product registration on elica.com. Register must be done within 3 months from purchase. For USA & Canada Only.

NIKOLA TESLA SWITCH

CUT OUT DIMENSIONS

SELF RIMMING INSTALLATION

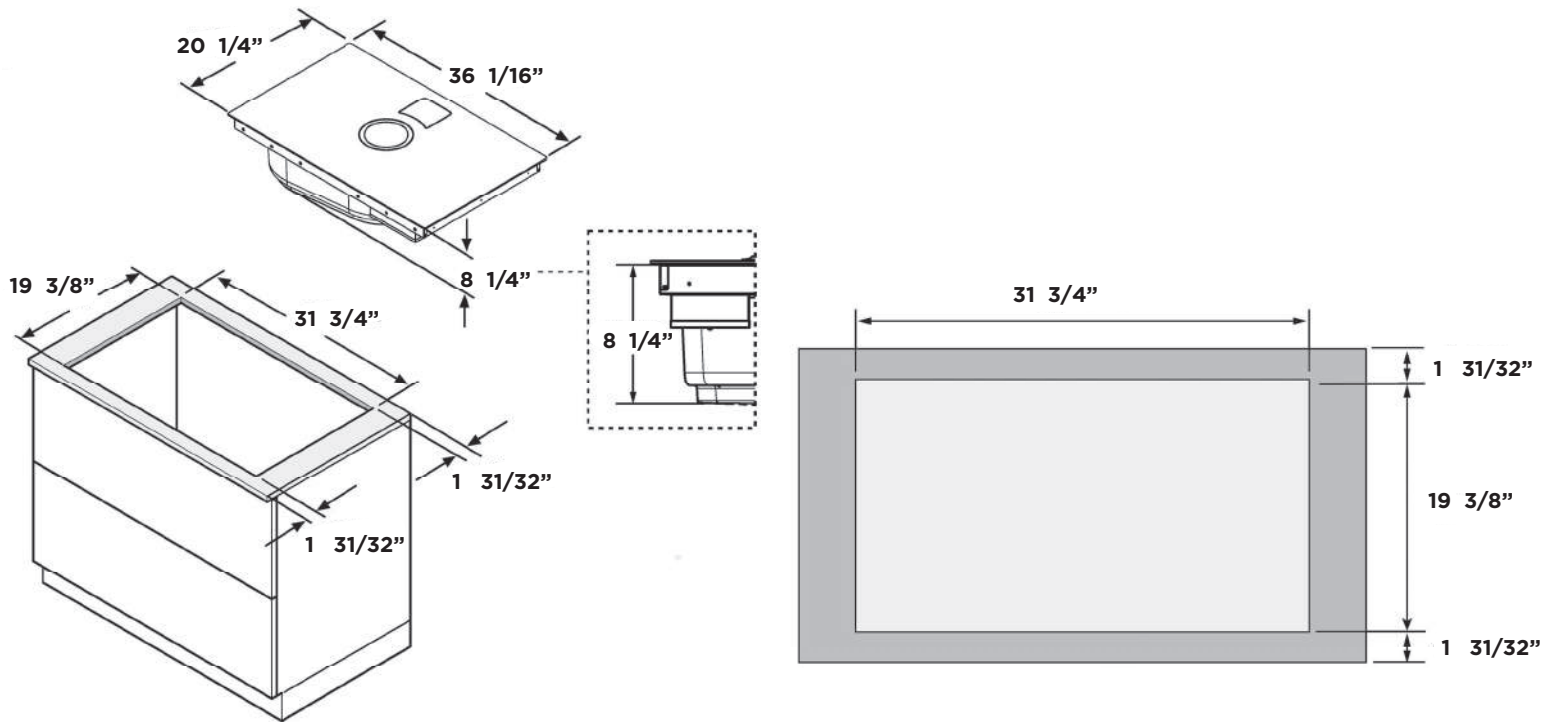

FLUSH MOUNTED INSTALLATION

