



ELICA'S EXCLUSIVE PLUS FEATURES

- CFM REDUCTION
- DIM LIGHT
- TOUCH CONTROL
- HUSH SYSTEM
- TOP PERFORMANCE
- LED LIGHT

Modena offers a classic designer chimney appearance for under-cabinet installations, with a striking 9" high pyramid shape. Modena also provides high-end features not commonly found in under-cabinet hoods, including 520 CFM blower, LED dimmable lighting, stainless steel microhole filters and easy to use glass capacitive touch controls that deliver convenience and safety.

Available in 30" or 36" width, and designed for standard ducted installation, Modena can also be installed as a recirculating system using the kit available as an accessory. For design versatility to suit almost any kitchen.

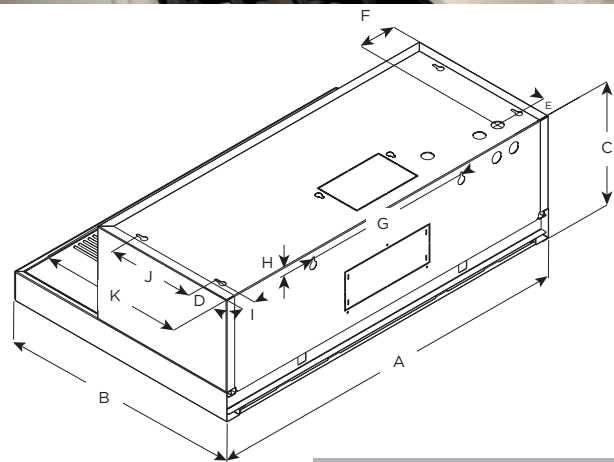

Models

	EMD530S3	EMD536S3
A	30" (76 cm)	36" (91.2 cm)
B	19 5/8" (50 cm)	
C	9 3/4" (25 cm)	
D	2 3/16" (5.5 cm)	
E	1 5/8" (4 cm)	
F	3" (7.6 cm)	5 3/4" (14.6 cm)
G	13 3/16" (35 cm)	
H	5/8" (1.6 cm)	
I	1 1/16" (3 cm)	
J	7 1/4" (18.4 cm)	
K	12" (30.5 cm)	



MOUNTING HEIGHT RANGE

- ≥24"
- ≥30"

For gas range installation: Mount this hood so that the bottom edge is at minimum 27" (68.6 cm) above the cooking surface. For electric range installation: mount this hood so that the bottom is not less than 24" (61 cm).

SPECIFICATIONS

Width:	30" UNIT	36" UNIT
Model:	EMD530S3	EMD536S3
Dimensions:	30"W x 19 5/8"D x 9 3/4"H	36"W x 19 5/8"D x 9 3/4"H
Blower Type(internal):**	600 CFM blower (3-speed internal + boost)	
Noise (sones):**	6.8 sones	
Finish:	Stainless Steel with Black Tempered Glass	
Controls:	Capacitive Touch (Glass)	
Illumination:	2 Premium Dimmable LED lights, 2.1 W, 4000 K	
Grease Filter:	Dishwasher-Safe, Stainless Steel Microhole Filter	
Duct Transition:	3 1/4" x 10" Rectangular (rear outlet) or 6" Round (top outlet)	
Installation Type:	Ducted or Recirculating (Kit sold separately)	
Electrical:	120 V - 60 Hz, 445 W	
KITS:		
Recirculating Kit:	KIT02667 (Contains 2 Round Carbon Filter)	
WARRANTY:***	Two (2) Years Parts & In-Home Labor. Earn an additional One (1) Year of Parts & In-Home Labor by registering on elica.com.	

PLUS FEATURES



HUSH SYSTEM - An exclusive sound deadening technology that effectively reduces sound levels up to 35%, compared to typical range hoods.



LED LIGHT - LED lighting is undoubtedly the smartest solution in terms of energy saving. Expected life is over 20,000 hours, and should last the full life of the hood.



CFM REDUCTION - CFM Reduction System (CRS), is an exclusive feature to Elica hoods, which enables the user to reduce the maximum blower CFM, to meet local code requirements.



DIM-LIGHT - The Dimmer allows you to adjust the brightness of the light as you wish. With Elica, lighting is customized in a discreet, personal and practical way, in order to contribute in creating the perfect kitchen atmosphere.



ELECTRONIC TOUCH CONTROLS - Enjoy the modern design and convenience of multi-function electronic touch controls, which are discreetly hidden behind sleek black glass, and will illuminate a soft blue when activated.



Certified Ratings	High Speed	Working Speed	Duct Size
CFM	410	180	6" (vertical)
Sones	7	1.5	
CFM	390	170	6" (horizontal)
Sones	8.5	2	

* The product images shown are for illustration purposes only and may not be an exact representation of the product.

** Blower performance indicates the performance of the blower by itself. Performance claims are not AHAM certified but were established in accordance with HVI Standardized test procedure. For Certified Ratings, please refer to AHAM Certified Product Directory. Electric Ratings are declared according to UL.

*** For valid warranty extension, register within 3 months from purchase. For USA & Canada Users Only.