

PERFORMANCE DATA NO LOAD & NO DOOR OPENINGS AT 37°/0° CONTROL SETTING			
Type A with Run / Start Capacitor	65°F (18°C) Ambient	90°F (32°C) Ambient	
Operating Time	90 to 100%	100%	
Freezer Temperature	-5° to 2°F (-20° to -17°C)	-1° to 3°F (-18° to -16°C)	
Refrigerator Temperature	34° to 39°F (1° to 4°C)	34° to 39°F (1° to 4°C)	
Low Side Pressure	-2 to 6 psig (-14 to 41 kPa)	-2 to 6 psig (-14 to 41 kPa)	
High Side Pressure (last 1/3 cycle)	85 to 105 psig (586 to 724 kPa)	120 to 135 psig (827 to 931 kPa)	
Wattage (last 1/3 cycle)	30 to 50	50 to 70	
Amps (running)	.4 to .8	.7 to .9	
Base Voltage	115 vac (127 vac max)		
DEFROST SPECIFICATIONS			
Cabinet Size	Thermostat		Heater
	Cut-in	Cut-out	Watts / Ohms
26' & 28' SD, 23' CD	25°F (-4°C)	47°F (8°C)	500 / 26.5
Electronic Timer - (ADC) Defrost 24 minutes every 6-96 hours of compressor run time.			
CONDENSER FAN MOTOR			
Watts	RPM	Amps	
3.1	1100 CW Opposite Shaft	0.03 Running	
FREEZER ICE MAKER SPECIFICATIONS			
Electrical	115 vac (127 vac max)		
Thermostat	Opens at 48°F (9°C), Closes at 15° F (-9°C)		
Heater Voltage	115 vac		
FREEZER ICE MAKER CONNECTOR PLUG CONNECTIONS			
Wire Number	Wire Color	Connects to:	
1	Green / Yellow	Ground	
2	Yellow	Water Valve	
3	Black	Line	
4	Light Blue	Neutral	

SERVICE DATA SHEET

242199100

ICE & WATER - AUTOMATIC DEFROST BOTTOM FREEZER - R134a

▶ **IMPORTANT: PLEASE RETURN THIS SHEET TO ITS ORIGINAL LOCATION.**

Error Codes			Special Modes			
Display	Interpretation	Mode	Display	Activate/Deactivate		
FZ	FF		FZ	FF	(press for up to 10 sec. simultaneously)	
--	OP	Open FF Thermistor	Manual Defrost	d	F	FF UP and FF DOWN / same to deactivate
OP	--	Open FZ Thermistor	Display / Showroom	77	77	FZ UP and FF DOWN / Power-on-Reset (POR)
--	SH	Shorted FF Thermistor	Sabbath	Sb	Sb	FZ DOWN and FF UP / same to deactivate
SH	--	Shorted FZ Thermistor	System Diagnostic	No FF or FZ display, all UI LEDs on.		FZ UP and FZ DOWN / FF UP to deactivate
SY	CF	UI to Main Control Board communication failure; on start up	FFIM Diagnostic	Numerical display of first test		FZ UP and FF UP together to activate / press and hold FF UP to deactivate
SY	CE	UI Main Control Board communication error; after a period in operation	Notes: • Always check for pin back-outs, pinched or damaged wires before replacing components. • Determine whether failure is caused by the component, main control board or wiring. Contact TID before replacing main control board. • Refer to Service Manual for additional information.			
SY	EF	Evaporator Fan Failure				

Fresh Food Ice Maker Diagnostic Mode			
Activate:	Press FZ UP and FZ DOWN temperature pads for up to 10 sec. simultaneously. Press FF UP or FF DOWN to move forward or backward through tests.		
Deactivate:	Press FF UP for up to 10 sec. FFIM Diagnostic Mode will automatically deactivate after 5 min. of inactivity. NOTE: Silence alarm.		
Test	To activate test	Passing Result	
52C	Ice Maker Thermistor	Activates automatically	FZ display shows temperature sensed by Ice Maker Thermistor. "OP" if open; "SH" if short
55C	Water Valve	Press power on-off	Remove ice tray to collect water into a measuring container to measure water fill. If collecting water into ice tray, first perform test 63C to empty ice tray.
57C	Evaporator Fan (FFIM)	Press power on-off	"On" on FZ display when fan activated, "OFF" when deactivated.
58C	Ice Level Sensor	Activates automatically	Remove ice bucket. Allow bail arm to drop freely. Pass if no alarm when tray returns to "home" position. Hold bail arm up. Pass if alarm sounds when tray returns to "home" position. This test runs continuously until another test is selected.
63C	Twist Tray	Press power on-off	Remove ice bucket. FZ display shows "1" and "GOOD".

System Diagnostic Mode			
Activate:	Press FZ UP and FZ DOWN temperature pads for up to 10 sec. simultaneously. Press FF UP to advance through tests.		
Deactivate:	Press FF UP for up to 10 sec. Diagnostic Mode will automatically deactivate after 5 min. of inactivity. Note: Silence alarm.		
<ul style="list-style-type: none"> • Tests marked with "" may not be applicable to this unit and will not be displayed in System Diagnostic Mode. • Tests displayed in diagnostic mode but not described below are for internal purposes only; advance through. • View UI display for "on," "off," "CL," "OP," "SH," "LO," "HI" or numerical results of tests. • Listen for operating sounds; feel for heat or air flow as appropriate to determine results of tests. 			
Test	To activate test:	Passing result	
--	First Screen	--	All LED lights on UI illuminated
--	Second Screen	--	All segments on UI temperature displays illuminated
--	Third Screen	--	Blank UI display, no lights illuminated, no shadowing; "-" and "+" blinking on FF display side to show location.
28	Dispenser Paddle	Press disp. paddle	"on" on UI when depressed; "off" when released
1*	Standard Compressor	Press power on-off	Compressor running when "on"; stopped when "off"
2	Defrost Heater	Press power on-off	Defrost limit switch must be closed; verify "CL" in test 26. Feel for heat from defrost heater when "on". If "OP" in test 26, heater will not activate.
3	FF Light	Press power on-off	With FF door open, FF lights on when "on"; off when "off"
8	Water Valve (Dispenser)	Press power on-off	FF door must be closed. Be prepared to collect water at dispenser. Water dispenses when "on"; stops when "off"
9	FZ Light	Press power on-off	With FZ door open, FZ lights on when "on", off when "off"
10	Auger Motor	Press power on-off	FF door must be closed. Motor running when "on"; motor stopped when "off"
11	Cube/Crush Solenoid	Press power on-off	FF door must be closed. Do not leave solenoid in activated state. Solenoid activated when "on"; deactivated when "off"
41*	Perfect Temp Drawer (PTD)	Press power on-off	PTD UI illuminated when "on", off when "off"
12*	VCC Condenser Fan	Press power on-off	Fan running when "on"; stopped when "off"
38*	VCC Compressor	Press power on-off	Compressor running when "on"; stopped when "off"
15	Evaporator Fan	Press power on-off	Fan running for minimum of 10 sec. when "LO" or "HI"; stopped when "off". Feedback failure if fan starts but runs less than 10 sec. Listen for speed change from "LO" to "HI".
22	Damper	Press power on-off	With inspection mirror, observe damper open when "OP"; closed when "CL"
23	FF Door	Open/close FF door	"CL" on UI when door closed; "OP" when open
24	FZ Door	Open/close FZ door	"CL" on UI when door closed; "OP" when open
26	Defrost Limit Switch	Activates automatically	"CL" on UI when closed; "OP" when open
36	Ice Chute Door	Depress ice chute door or press power on-off	"OP" on UI when manually opened; "CL" when closed. Or, using "power on-off", "OP" on UI when solenoid activated, "CL" when deactivated
29	FF Thermistor Mid-level	Activates automatically	UI shows temperature sensed by FF thermistor; pass if within 10°F of temperature measured with gauge at mid-level FF thermistor location. "OP" if open; "SH" if short
30	FZ Thermistor	Activates automatically	UI shows temperature sensed by FZ thermistor; pass if within 10°F of temperature measured with gauge at FZ thermistor location. "OP" if open; "SH" if short
33	Ambient Thermistor @ Main Board	Activates automatically	UI shows temperature sensed at main board; pass if within +20°F/-10°F of temperature measured with gauge at main board location. "OP" if open; "SH" if short
35*	FF Thermistor Upper-Level	Activates automatically	UI shows temperature sensed by upper level FF thermistor; pass if within 10°F of temperature measured with gauge at upper-level FF thermistor location. "OP" if open; "SH" if short
34*	Ambient Thermistor @ UI	Activates automatically	UI shows temperature sensed at UI; pass if within +20°F/-10°F of temperature measured with gauge at UI location. "OP" if open; "SH" if short
0-	Firmware Parameters	Press power on-off	Displays digit sequence; record
2-	Main Board Firmware	Press power on-off	Displays digit sequence; record
4-	UI Firmware	Press power on-off	Displays digit sequence; record

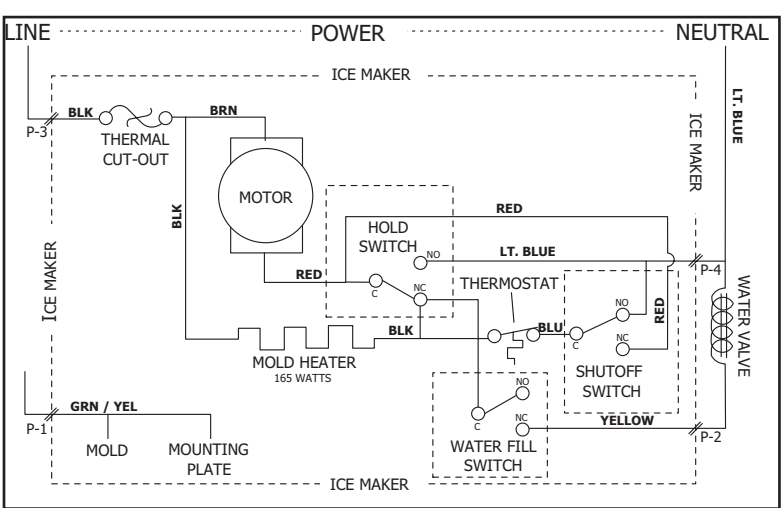

Variable Capacity Compressor (VCC) Diagnostics (select models)

If test 38 fails, diagnose as follows:

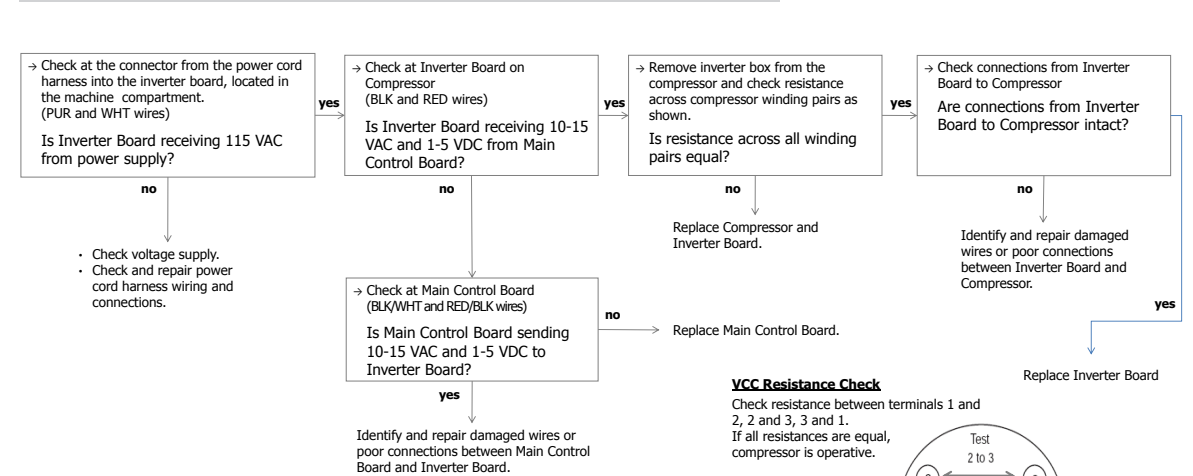

CAUTION
All electrical parts and wiring must be shielded from torch flame. DO NOT allow torch to touch insulation; it will char at 200°F and flash ignite (burn) at 500°F. Excessive heat will distort the plastic liner.

FREEZER ICE MAKER INFORMATION

(Where Applicable)

Test Cycling: Remove cover by inserting screwdriver in notch at bottom and prying cover from housing. Use screwdriver to rotate motor gear counterclockwise until holding switch circuit is completed. All components of ice maker should function to complete the cycle.

Water Fill Volume: The water fill adjustment screw will change the fill time. One full turn is equal to 20cc (.68 oz.). The correct fill is 102 to 130cc (3.4 to 4.3 oz.). When a water valve is replaced, the fill volume must be checked.

IMPORTANT SAFETY NOTE
The information provided herein is designed to assist qualified repair personnel only. Untrained persons should not attempt to make repairs due to the possibility of electrical shock. Disconnect power cord before servicing this appliance.

IMPORTANT
If any green grounding wires are removed during servicing, they must be returned to their original position and properly secured.

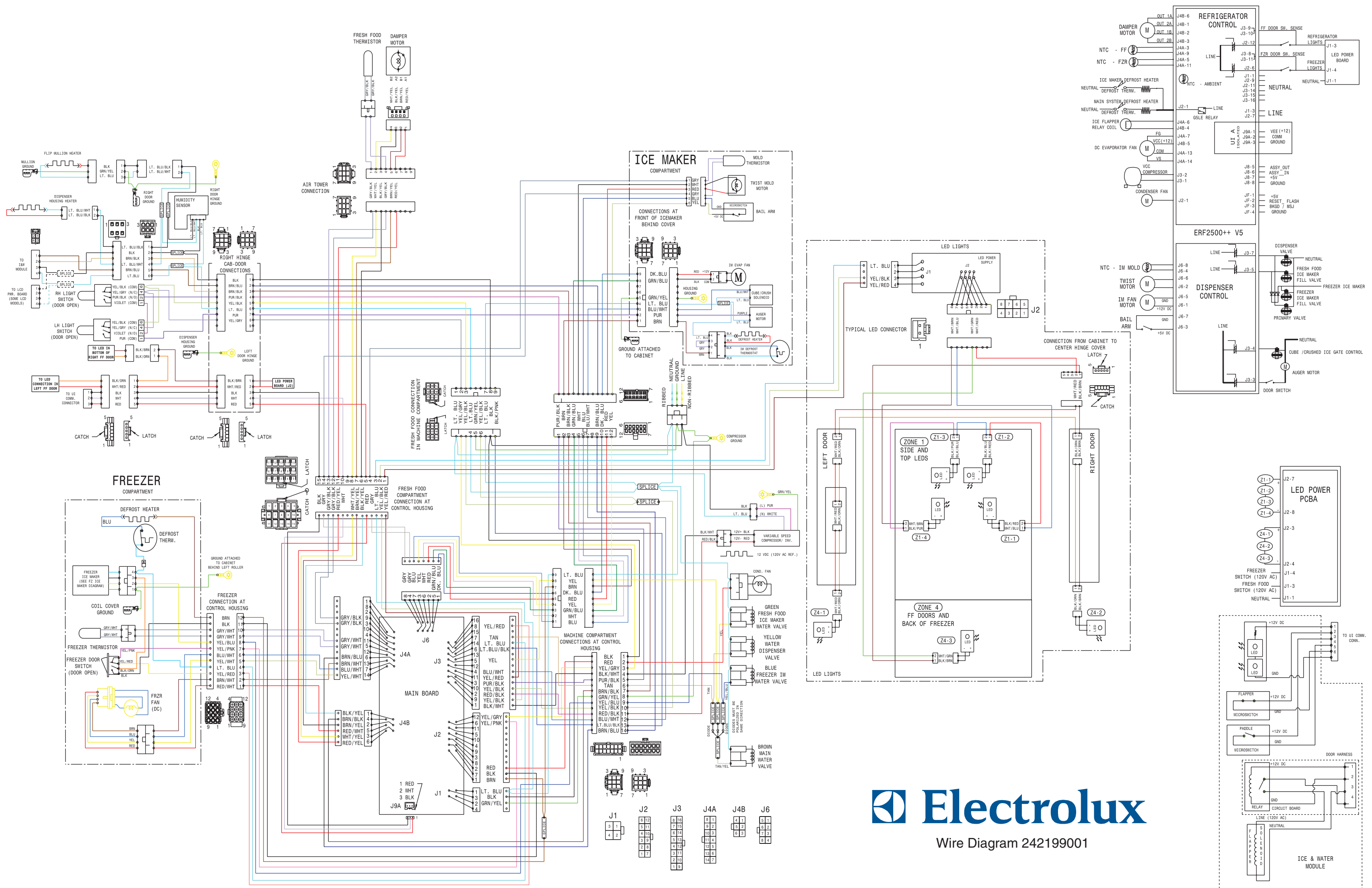

Wire Diagram 242199001