

6" Super Sloped IC Airtight Medium Base Double Wall New Construction Housing

ELCO Slant allows for installation in sloped ceilings ranging from 7/12 (30°) to 12/12 (45°). Can be used in insulated ceilings. Fits in 2" x 8" joist construction.

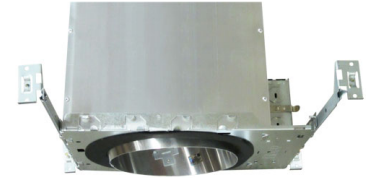

Features

- Airtight aluminum Double Wall Construction.
- Integral thermal protector guards against improper lamping.
- Designed for use in 7/12 to 12/12 sloped ceiling.
- Socket: Medium base E26.
- Compatible with Medium Base Incandescent, CFL or LED Lamp MAX. 90W. Works with LED Quick-Connect Inserts with PSA30 Socket Adapter.

Specifications

Wattage	90W
Voltage	120V
Lamp Type	Medium Base (E26)
Damp Location	Listed

Dimensions

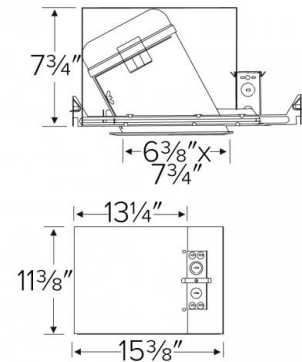

Technical Details

Construction:

- IC Rated for Direct Contact with Insulation.
- Designed for use in 7/12 to 12/12 sloped ceiling.
- Housing adjusts in frame to accommodate up to 1 1/4" ceiling thickness.
- Aluminum housing for greater heat dissipation. Stamped galvanized steel frame.

Installation: Designed for ceiling plenums where 2x8 joists or taller are used. High strength hanger bars can easily be nailed to joists. Template for hole cutout is provided with each housing. Suitable for T-grid and drop ceiling applications. See installation sheet for detailed information.

Junction Box: Positioned to accommodate straight conduit runs. Seven 1/2" trade size conduit knockouts and four pry-out knockout slots for easy romex installation.

Hanger Bars: Pre-installed hanger bars with True Nail easy installation in regular lumber, engineered lumber, and Laminated Beams. Integral T-bar slots for easy installation in T-Bars. Spans up to 24" and can be repositioned 90°. Score lines allow for tool-free hanger bar size reduction. Integral leveling flange allows for single-person installation while aligning the housings with the joists.

Electrical:

- Rated for 120V or 277V input.
- For 277V step down to 120V housing consult factory.

Trims: Compatible with EL602, EL603, EL604, EL606, EL607, EL608.

Listings: UL Listed for Damp Location.

UL Listed for Direct Contact with Insulation and Combustible Material.

UL Listed for Feed Through.

Meets restricted air flow requirements (Per ASTM E-283 Standard).

Product Numbers

Item	Lamp type	Watts	Voltage
EL946ICA	Medium Base (E26)	90W	120V