

5" IC Airtight Shallow New Construction Housing for LED Inserts, 17W Max



Features

- Shallow single wall IC construction, for use in insulated ceilings.
- CA Title 24 compliant (as high efficiency luminaire).
- Trims sold separately.
- Lamp: 17W Max 120V.
- UL Listed for damp location and for feed through.
- Compatible with ELCO 5" LED Inserts.

Specifications

Wattage	17W
Voltage	120V
Damp Location Listed	

Dimensions

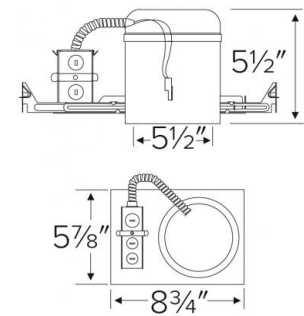

Technical Details

Construction:

- Shallow single wall IC rated for direct contact with insulation, for use in IC or non-IC conditions.
- Housing adjusts in frame to accommodate up to 1 1/4" ceiling thickness.
- Airtight housing with gasket to restrict airflow in accordance with ASTM E-283 air-tight requirements.

Installation: Designed for ceiling plenums where 2x6 joists or taller joists are used. High strength hanger bars can easily be nailed to joists. Maximum hole cutout is 5 1/2". Suitable for T-grid and drop ceiling applications. See installation sheet for detailed information.

Junction Box: Positioned to accommodate straight conduit runs. Seven 1/2" trade size conduit knockouts, four 3/4" knockouts with pry-out knockout slots. 4 Romex pryouts with strain relief.

Hanger Bars: Pre-installed hanger bars with TrueNail facilitate easy installation in regular lumber, engineered lumber, and laminated beams. Integral T-bar slots for easy installation in T-bars. Spans up to 24" and can be repositioned 90°. Score lines allow for tool-free hanger bar size reduction. Integral leveling flange allows for single-person installation while aligning the housings with the joists.

Electrical: Input Voltage: 120V AC. Inherently protected.

Dimmability: Dimmability based on lamp.

Lamp: Designed for use with ELCO 5" LED inserts, LED modules, or PSA37 with 5" MR16 trims.

Listings:

- UL Listed for Damp Location.
- UL Listed for Wet Location with select trims.
- UL Listed for Feed Through.
- UL Listed for Direct Contact with Insulation and Combustible Material.
- Airtight per ASTM E-283.
- Install a JA8-2016-E lamp for Title 24 Compliance.

Warranty: ELCO Lighting warrants products will be free from defects in materials and workmanship for a period of 5 years.

Product Number

Item	Watts	Voltage
EL560ICA	17W	120V

Compatible Products

For use with Dedicated 5" Dedicated IC LED Housings

5" LED Inserts



Round Reflector

CAT NO.	SPECIFICATIONS
EL61527W, BZ	10W, 800 lm, 2700K
EL61530W, BZ	10W, 850 lm, 3000K
EL61535W, BZ	10W, 900 lm, 3500K
EL61540W	10W, 900 lm, 4000K
EL61550W	10W, 950 lm, 5000K
EL615CT5W, BZ	12W, 880 lm - 1080 lm, 2700K - 5000K



Round Reflector

CAT NO.	SPECIFICATIONS
EL61727W	14W, 1000 lm, 2700K
EL61730W	14W, 1000 lm, 3000K
EL61735W	14W, 1100 lm, 3500K
EL61740W	14W, 1200 lm, 4000K
EL617CT5W	12W, 880 lm - 1080 lm, 2700K - 5000K



Round Reflector

CAT NO.	SPECIFICATIONS
EL62727W	20W, 1400 lm, 2700K
EL62730W	20W, 1400 lm, 3000K
EL62735W	20W, 1500 lm, 3500K
EL62740W	20W, 1600 lm, 4000K



Round Deep Reflector

CAT NO.	SPECIFICATIONS
EL62527W, C, H	14W, 1000 lm, 2700K
EL62530W, C, H	14W, 1000 lm, 3000K
EL62535W, C, H	14W, 1100 lm, 3500K
EL62540W, C, H	14W, 1200 lm, 4000K
EL625CT5W	12W, 840 lm - 1100 lm, 2700K - 5000K



Round Insert

CAT NO.	SPECIFICATIONS
EL615SDW, BZ	10W, 750 lm, Sunset, Reflector
EL610SDW, BZ	10W, 750 lm, Sunset, Baffle



Round Baffle

CAT NO.	SPECIFICATIONS
EL61027W	10W, 800 lm, 2700K
EL61030W	10W, 850 lm, 3000K
EL61040W	10W, 900 lm, 4000K
EL610CT5W	12W, 880 lm - 1080 lm, 2700K - 5000K



Round Baffle

CAT NO.	SPECIFICATIONS
EL61130W	14W, 1000 lm, 3000K
EL61140W	14W, 1200 lm, 4000K
EL611CT5W	14W, 850 lm - 1400 lm, 2700K - 5000K



Round Baffle

CAT NO.	SPECIFICATIONS
EL61230W	20W, 1400 lm, 3000K
EL612CT5W	12W, 850 lm - 1400 lm, 2700K - 5000K



Round Gimbal

CAT NO.	SPECIFICATIONS
EL61627W	13W, 930 lm, 2700K
EL61630W	13W, 950 lm, 3000K

*Finishes: **W** - All White, **BZ** - All Bronze, **C** - Chrome w/White Ring, **H** - Haze w/White Ring

Compatible Products

For use with Dedicated 5" Dedicated LED IC LED Housings

5" LED Inserts



Round Deep Baffle

CAT NO.	SPECIFICATIONS
EL62127W	14W, 1000 lm, 2700K
EL62130W	14W, 1000 lm, 3000K



Square Reflector

CAT NO.	SPECIFICATIONS
EL55230W	16W, 1300 lm, 3000K



Square Baffle

CAT NO.	SPECIFICATIONS
EL55130W	16W, 1300 lm, 3000K



Round Pull Down Adjustable

CAT NO.	SPECIFICATIONS
EL59727W, B, BZ	12.6W, 800 lm, 2700K
EL59730W, B, BZ	12.6W, 840 lm, 3000K

5" Accessories



Emergency Battery Backup

CAT NO.	SPECIFICATIONS
KEM-LD5	8W, 120/277V



Fire Cover

CAT NO.	SPECIFICATIONS
FIRECVR	9 3/4" H x 17" O.D.



Fire Enclosure

CAT NO.	SPECIFICATIONS
FIREENCL	20 3/8" L x 14 3/8" W
FIREENCL-S	Shallow, 16" L x 14 3/8" W



Mica Fire Tape

CAT NO.	SPECIFICATIONS
FIRETAPE	3/4" W x 16' L



Cover Plate Color Trims

CAT NO.	SPECIFICATIONS
RMLD6B	Black
RMLD6BZ	Bronze
RMLD6C	Chrome

*Finishes: **W** - All White, **B** - All Black, **BZ** - All Bronze, **C** - Chrome w/White Ring, **H** - Haze w/White Ring