

8" New Construction Plaster Frame with Driver



Features

- Optional 90 minutes, 120/277 VAC, 60Hz Emergency Backup.
- USA designed and assembled.
- LED Light Engine sold separately (see Compatible Products).
- 2 at the end of the item number denotes Generation 2. Please note Gen 2 and Gen 1 are not cross compatible.

Specifications

Lumens	850 lm
Voltage	120/277V
Dimmable	Triac/ELV/0-10V
Power Factor	≥0.9
Damp Location	Listed

Options



Optional EM Battery Back-up

Technical Details

Construction:

Constructed from 16 gauge galvanized steel for commercial building applications.

Installation:

High strength hanger bars can easily be nailed to joists. Suitable for T-grid and drop ceiling applications. See installation sheet for detailed information.

Junction Box: Positioned to accommodate straight conduit runs. Seven 1/2" trade size conduit knockouts and four pry-out knockout slots for easy romex installation.

Hanger Bars: Pre Installed hanger bars with True Nail easy installation in regular lumber, engineered lumber, and Laminated Beams. Integral T-bar slots for easy installation in T-Bars. Spans up 24" and can be repositioned 90°. Score lines allow for tool-free hanger bar size reduction. Integral leveling flange allows for single-person installation while easily aligning the housings with the joists.

Electrical:

- Driver is rated for 120V and 277V input (120/277V).
- High Efficiency driver with a power factor > 0.9.
- Can be specified with Lutron drivers for specific applications.

Dimmability:

- 3 in 1 dimming: Triac, ELV and 0-10V dimming in one driver.
- 0-10V dimming down to 5% with a compatible dimmer.
- Flicker-Free Dimming.
- Can be specified with Lutron drivers for 0.1% and 1% dimming.
- For a full list of dimmers refer to the Dimmer Compatibility List.

Listings: cULus Listed for Damp Location. cULus Listed for Wet Location with select trims. cULus Listed for Direct Contact with Insulation and Combustible Material for units up to 2000 lm. cULus Listed for Feed Through.

Warranty: ELCO Products are built to last. 5-year Limited warranty.

Dimensions

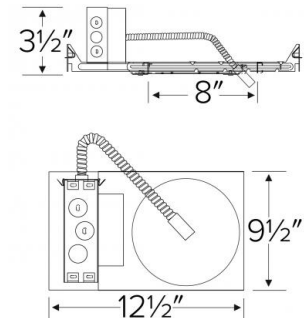

Product Number

Item	Lumens	Voltage	Dimming
E8LFU08D2	850 lm	120/277V	Triac/ELV/0-10V

Product Number Builder

Example: **E8LFU08D2**

ELCO Laurel 8" Plaster Frame	Voltage	Lumens	Dimming	Generation
E8LF	U 120/277V	08 850 lm 12 1250 lm 16 1600 lm 20 2000 lm 30 3000 lm 40 4000 lm 60 6000 lm	D Triac/ELV/0-10V S Sunset L Lutron	Gen 1 2 Gen 2
Optional				
No EM				
EM1 8W Emer. Backup				
EM2 12W Emer. Backup				

Compatible Products



For use with 8" Laurel™ Frames

8" Laurel™ Commercial LED Light Engines

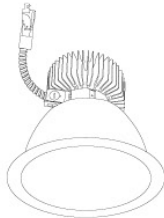

Reflector Trim
E810L

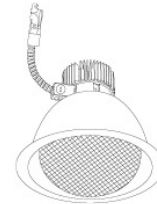

Wall Wash Trim
E811L



Drop Glass Trim
E812L

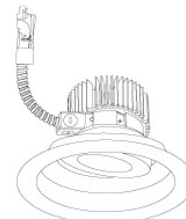

Adjustable Trim
E818L

PRODUCT NUMBER BUILDER

Laurel™ Trim	Lumen	Color Temperature	Finish	Generation
<input type="text"/>	<input type="text"/>	<input type="text"/>	<input type="text"/>	<input type="text"/>
E810L Reflector	08 850 lm	27 2700K	W All White	(blank) Gen 1
E811L Wall Wash	12 1250 lm	30 3000K	B All Black	2 Gen 2
E812L Drop Glass	16 1600 lm	35 3500K	C All Chrome	
E818L Adjustable	20 2000lm	40 4000K	H All Haze	
	30 3000lm	SD Sunset Dimming	HW Haze w/White Ring	
	40 4000lm			
	60 6000lm			