

6" New Construction Plaster Frame with Driver



Features

- Optional 90 minutes, 120/277 VAC, 60Hz Emergency Backup.
- USA designed and assembled.
- LED Light Engine sold separately (see Compatible Trims).
- 2 at the end of the item number denotes Generation 2. Please note Gen 2 and Gen 1 are not cross compatible.

Specifications

Lumens	1600 lm
Voltage	120/277V
Dimmable	Triac/ELV/0-10V
Power Factor	≥0.9
Damp Location	Listed

Options



Optional EM Battery Back-up

Technical Details

Construction:

Constructed from 16 gauge galvanized steel for commercial building applications.

Installation:

High strength hanger bars can easily be nailed to joists. Suitable for T-grid and drop ceiling applications. See installation sheet for detailed information.

Junction Box: Positioned to accommodate straight conduit runs. Seven 1/2" trade size conduit knockouts and four pry-out knockout slots for easy romex installation.

Hanger Bars: Pre Installed hanger bars with True Nail easy installation in regular lumber, engineered lumber, and Laminated Beams. Integral T-bar slots for easy installation in T-Bars. Spans up 24" and can be repositioned 90°. Score lines allow for tool-free hanger bar size reduction. Integral leveling flange allows for single-person installation while easily aligning the housings with the joists.

Electrical:

- Driver is rated for 120V and 277V input (120/277V).
- High Efficiency driver with a power factor > 0.9.
- Can be specified with Lutron drivers for specific applications.

Dimmability:

- 3 in 1 dimming: Triac, ELV and 0-10V dimming in one driver.
- 0-10V dimming down to 5% with a compatible dimmer.
- Flicker-Free Dimming.
- Can be specified with Lutron drivers for 0.1% and 1% dimming.
- For a full list of dimmers refer to the Dimmer Compatibility List.

Listings: cULus Listed for Damp Location. cULus Listed for Wet Location with select trims. cULus Listed for Direct Contact with Insulation and Combustible Material for units up to 2000 lm. cULus Listed for Feed Through.

Warranty: ELCO Products are built to last. 5-year Limited warranty.

Dimensions

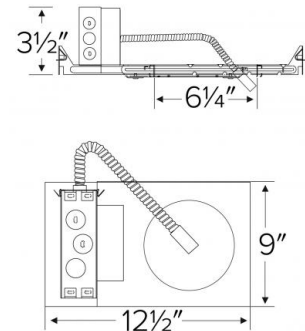

Product Number

Item	Lumens	Voltage	Dimming
E6LFU16D2	1600 lm	120/277V	Triac/ELV/0-10V

Product Number Builder

Example: **E6LFU08D2**

ELCO Laurel 6" Plaster Frame	Voltage	Lumens	Lumens	Generation
E6LF	U 120/277V	08 850 lm 12 1200 lm 16 1600 lm 20 2000 lm 30 3000 lm 40 4000 lm 60 6000 lm	D Triac/ELV/0-10V S Sunset L Lutron	Gen 1 2 Gen 2

Optional

- (blank)** No EM
- EM1** 8W Emer. Backup
- EM2** 12W Emer. Backup

Compatible Products

For use with 6" Laurel™ Frames



6" Laurel™ Commercial LED Light Engines

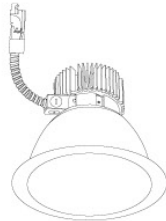

Reflector Trim
E610L

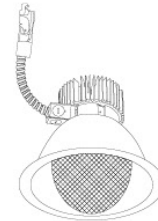

Wall Wash Trim
E611L

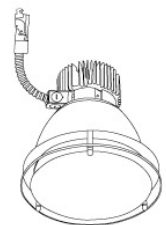

Drop Glass Trim
E612L

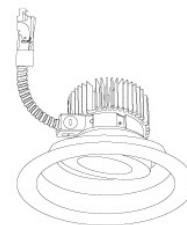

Adjustable Trim
E618L

PRODUCT NUMBER BUILDER

Laurel™ Trim		Lumen		Color Temperature		Finish		Generation	
<input type="text"/>		<input type="text"/>		<input type="text"/>		<input type="text"/>		<input type="text"/>	
E610L	Reflector	08	850 lm	27	2700K	H	All Haze	(blank)	Gen 1
E611L	Wall Wash	12	1250 lm	30	3000K	W	All White	2	Gen 2
E612L	Drop Glass	16	1600 lm	35	3500K	B	All Black		
E618L	Adjustable	20	2000lm	40	4000K	C	All Chrome		
		30	3000lm	SD	Sunset Dimming	HW	Haze w/White Ring		
		40	4000lm						
		60	6000lm						