

4" New Construction Architectural Frame with Driver



Features

- Optional 90 minutes, 120/277 VAC, 60Hz Emergency Backup.
- USA designed and assembled.
- LED Light Engine and Hanger bars sold separately (see Compatible Products).
- 2 at the end of the item number denotes Generation 2. Please note Gen 2 and Gen 1 are not cross compatible.

Specifications

Lumens	1250 lm
Voltage	120/277V
Dimmable	Triac/ELV/0-10V
Power Factor	≥0.9
Damp Location	Listed

Options



Optional EM Battery Back-up

Technical Details

Construction:

Constructed from 16 gauge galvanized steel for large architectural applications. Housing adjusts in frame to accommodate up to 2" ceiling thickness.

Installation:

Designed for architectural buildings. Easily installed with hanger bars (ordered separately for specific application type). Light engine installed into frame.

Junction Box: Positioned to accommodate straight conduit runs. Seven 1/2" trade size conduit knockouts and four pry-out knockout slots for easy romex installation.

Hanger Bars: Hanger bars ordered separately as FB27: Set of two 27" hanger bars for wood construction or CH26: Set of two 26" C-Channel hanger bars for T-Bar Ceiling.

Electrical:

- Driver is rated for 120V and 277V input (120/277V).
- High Efficiency driver with a power factor > 0.9.
- Can be specified with Lutron drivers for specific applications.

Dimmability:

- 3 in 1 dimming: Triac, ELV and 0-10V dimming in one driver.
- 0-10V dimming down to 5% with compatible dimmer.
- Flicker-Free Dimming.
- Can be specified with Lutron drivers for 0.1% and 1% dimming.
- For full list of dimmers refer to the Dimmer Compatibility List.

Listings: cULus Listed for Damp Location. cULus Listed for Wet Location with select trims. cULus Listed for Direct Contact with Insulation and Combustible Material for units up to 1600 lm. cULus Listed for Feed Through.

Warranty: ELCO Products are built to last. 5-year Limited warranty.

Dimensions

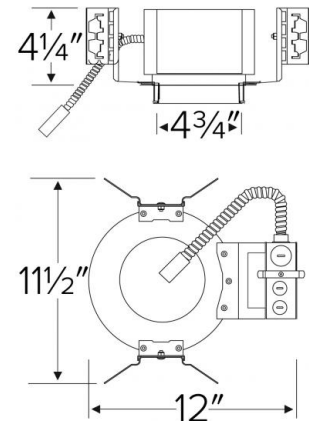

Product Number

Item	Lumens	Voltage	Dimming
E4LHU12D2	1250 lm	120/277V	Triac/ELV/0-10V

Product Number Builder

Example: **E4LHU08D2**

ELCO Laurel 4" Architectural Frame	Voltage	Lumens	Dimming	Generation
E4LH	U 120/277V	08 850 lm 12 1250 lm 16 1600 lm 20 2000 lm 30 3000 lm	D Triac/ELV/0-10V S Sunset L Lutron	Gen 1 2 Gen 2
Optional				
No EM				
EM1 8W Emer. Backup				
EM2 12W Emer. Backup				

Compatible Products



For use with 4" Laurel™ LED Frames

4" Laurel™ Commercial LED Light Engines



Round Reflector Trim
E410L



Round Wall Wash Trim
E411L

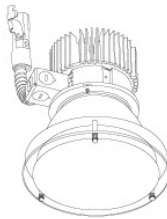

Drop Glass Reflector Trim
E412L

PRODUCT NUMBER BUILDER

Laurel™ Trim		Lumen		Color Temperature		Finish		Generation	
<input type="text"/>		<input type="text"/>		<input type="text"/>		<input type="text"/>		<input type="text"/>	
E410L	Reflector	08	850 lm	27	2700K	H	All Haze	(blank)	Gen 1
E411L	Wall Wash	12	1250 lm	30	3000K	W	All White	2	Gen 2
E412L	Drop Glass	16	1600 lm	35	3500K	B	All Black		
		20	2000lm	40	4000K	C	All Chrome		
		30	3000lm	SD	Sunset Dimming	HW	Haze w/White Ring		