

HotMax™ with Heat Primed Technology™

Specifications

Electric Tankless Water Heater

Complete dispensing system providing endless near-boiling water

Applications

- Foodservice
- Coffeehouse/café
- Restaurants/kitchens
- Hotels/hospitality
- Cafeteria

Performance Features

- Designed for the rigors of commercial foodservice applications
- Provides endless, near-boiling water with no downtime
- Industry leading volume of 480 cups per hour at continuous flow
- Heat Primed Technology™ delivers near-boiling water from first cup to last
- Stylish gooseneck dispenser
- Faucet features patent pending SteamShield™ technology delivering near-boiling water in a steady flow for operator safety
- Splash-free fluid dispensing with no undesirable steam
- Temperature consistency of +/- 2°F at steady state
- Broad temperature range of 140°F – 200°F
- Easy-to-adjust temperature control dial with 11 settings
- Recovery-free operation
- Compact size for flexible installation
- Faucet easily mounts in standard sink opening
- Warranty, five (5) years limited on leaks, one (1) year parts
- Certifications: NSF 61 Lead Free Certified, ETL certified (U.S. & Canada)

System Specifications

Dimensions:	12"H x 7"W x 5"D
Weight:	6 lb
Cover:	Plastic - light texture
Color:	Gray
Temperature Range:	140-200°F
Dynamic Operating Pressure:	30-150 PSI
Optimum Operating Pressure:	55-80 PSI
Element:	Replaceable brass copper cartridge insert
Inlet Fitting:	3/8" compression fittings
Outlet Fitting:	Proprietary - 4mm tube (1/4" compression fitting)
Turn On:	0.3 GPM
Max Flow Rate:	0.5 GPM (at 60 PSI)

U.S. Patent Pending Technology

Faucet Specifications

Height:	11.5"
Surface:	Chrome plating, lead free
Min. Rotary Ability:	180°
Outlet Angle Tolerance:	+/- 5°
Nut Materials:	Plastic PA66 and copper
Lever:	Spring return lever
Outlet Flow:	Laminar flow stream

U.S. Patent Pending Technology



NO LEAD™

*The wetted surface of this product contacted by water contains less than 0.25% lead and meets NSF 61



Special Design Service

Inquiries for units for unique applications are welcome. Call our Technical Service department at **1-800-543-6163**.

Suggested Specification

Instant near-boiling water dispensing system shall be an Eemax HotMax model number HMO13240.

Unit shall integrate electric tankless technology with a dispensary system (faucet) to supply near-boiling water. Unit shall have a 0.3 GPM turn on. Unit shall be limited to a max flow at 0.5 GPM. Element shall be replaceable copper sheathed with brass flange cartridge insert. Outlet fitting shall include an insulated 4mm tube. Faucet shall deliver water in a laminar flow stream. Unit shall modulate power to the heating elements to maintain a user-selected output temperature between 140°F-200°F (subject to incoming water temperature). The unit shall be equipped with both computer-controlled and electromechanical auto resetting thermostat switches for high-limited temperature protection. The unit shall include a dispensary system that will allow liquid to pass through internal screen(s) and be shaped into a laminar flow stream that is conducive to splash-free fluid dispensing for any number of uses. Unit shall employ technology to separate near-boiling water from undesirable steam- applicable for any application where the separation of liquid and gas is desired at the point of dispensing.



Eemax, 400 Captain Neville Drive, Suite 1, Waterbury, CT 06705
(800) 543-6163 | info@eemaxinc.com | www.eemax.com

HotMax with Heat Primed Technology

Specifications

Electric Tankless Water Heater

Complete dispensing system providing endless near-boiling water

MODEL NUMBER	KW	AMPS	RECOMMENDED WIRE SIZE	INLET FITTING	OUTLET FITTING	TURN ON (GPM)	MAX FLOW (GPM)
VOLTS 240							
C HM013240	13	54 A	6 AWG	3/8" CF	proprietary - 4mm tube (1/4" CF)	0.3	0.5 (at 60 PSI)

"C" indicates evaluation and compliance to either Underwriters Laboratories (UL) or Intertek (ETL) under CAN/CSA-C22.2 No. 64/No. 88.

Installation Considerations

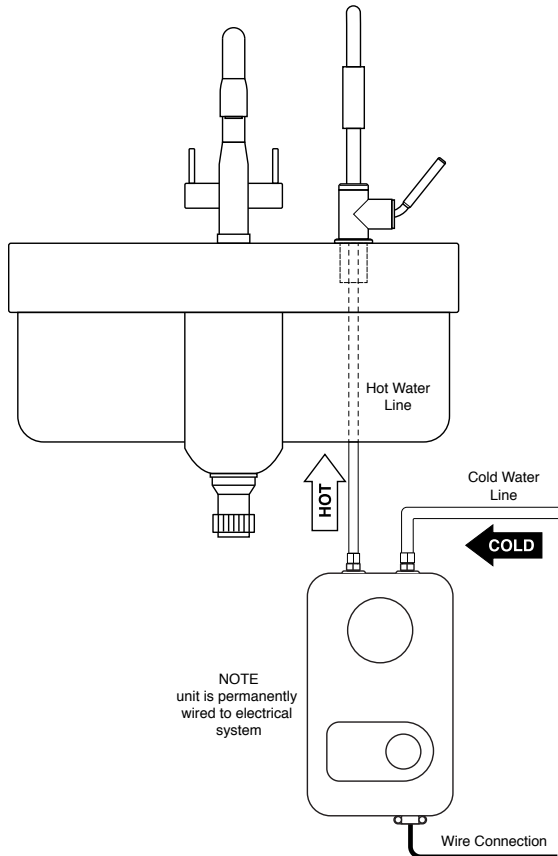

- Mount heater within 25" of the faucet fittings.
- Near-boiling water is assured at any location regardless of ground water temperature
- Verify that your garbage disposal is capable of withstanding temperatures up to 200°F
- Turn down the set point on the heater to compensate for high altitude locations
- Separate 8 AWG ground conductor
- 60 A double pole breaker
- A filter may be installed ahead of the unit

Faucet Dimensions

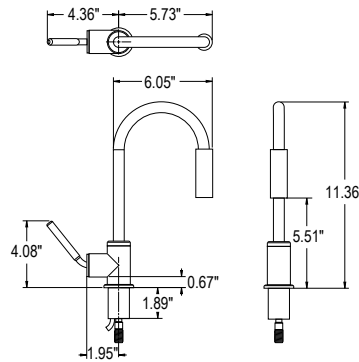

Heater Dimensions

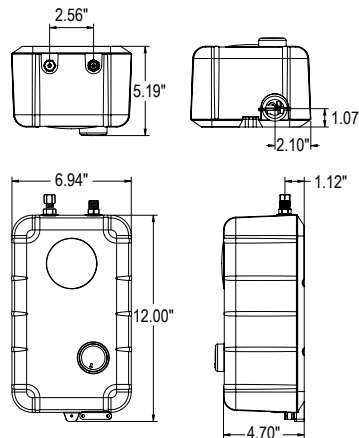

Eemax, 400 Captain Neville Drive, Suite 1, Waterbury, CT 06705
(800) 543-6163 | info@eemaxinc.com | www.eemax.com

Information and product specifications contained in this document are subject to change without notice.
© 2018 Eemax, Inc. All Rights Reserved. REV 2018-03