

# EDGESTAR<sup>®</sup>

## Built-In Side Burners

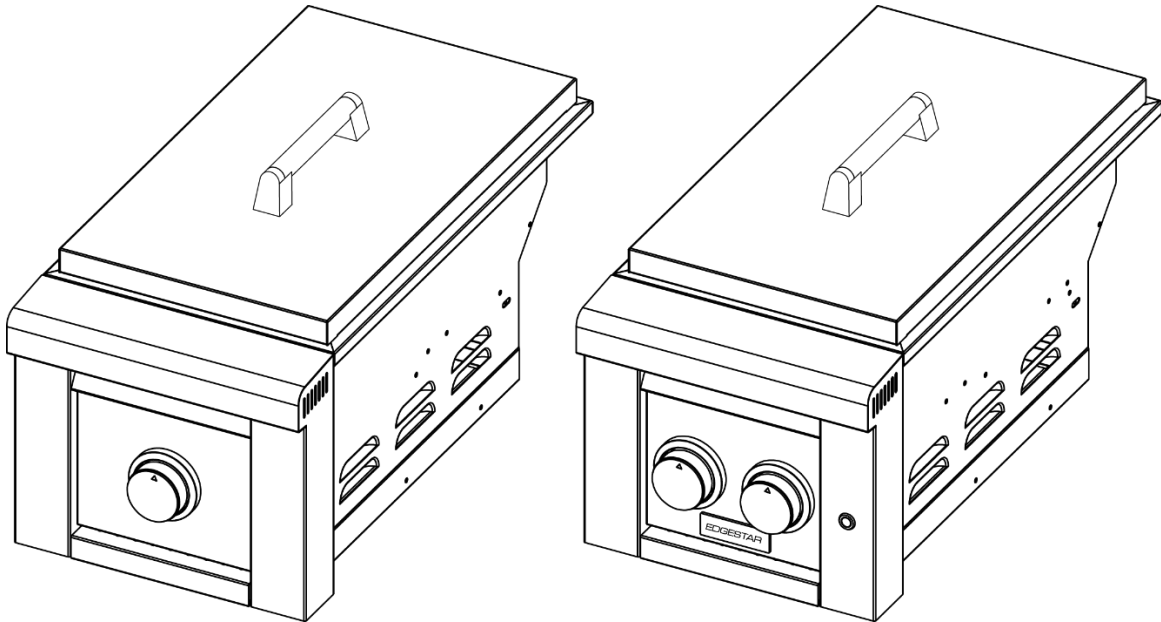

### Side Burner Models:

**ESB1NG / ESB1LP  
ESB2NG / ESB2LP**

## Owner's Manual

For more information on other great EdgeStar products on the web, go to <https://www.edgestar.com>

# Important Safety Information

Improper handling can cause serious damage to the EdgeStar side burner and/or injury to the user. This side burner is designed for domestic use only. **Do not use the unit for industrial or commercial use.** Do not use in any enclosed areas, including buildings and garages. Any other use may invalidate the warranty. Please review the ratings label for technical data related to this unit.

**Please read and follow the safety information listed below to reduce the risk of fire, electric shock, or injury.**



## **DANGER**

**If you smell gas:**

- **Shut off gas to the appliance.**
- **Extinguish any open flame.**
- **Open lid.**
- **If odor continues, keep away from the appliance and immediately call your gas supplier or your fire department.**



## **WARNING**

- **Do not store or use gasoline or other flammable liquids or vapors in the vicinity of this or any other appliance.**
- **An LP cylinder not connected for use shall not be stored in the vicinity of this or any other appliance.**



**Important: Your gas side burner is to be used outdoors only.**

## **PROTECT CHILDREN:**

Keep children away from the side burner during use and until the side burner has cooled after you are finished using it. Do not allow children to operate the side burner.



## Gas and Electrical Safety

- This gas side burner must be installed in accordance with all local codes. In addition, the gas side burner(s) must be installed in accord with the following codes, as applicable:
  - *National Fuel Gas Code, ANSI Z223.1 / NFPA 54*
  - *Natural Gas and Propane Installation Code, CSA B149.1*
  - *Propane Storage and Handling Code, CSA B149.2*
- Where applicable, a standard electrical supply (115V, 60Hz) must be used for lights, rotisserie motor(s), and all other apparatus that need to be plugged in. Electrical supplies must be properly grounded in accordance with the *National Electrical Code, ANSI / NFPA 70*. Compliance with local codes and ordinances is required.
- Never use dented, rusty, or damaged propane tanks.
- Always have an ABC fire extinguisher nearby. Never attempt to use water to extinguish a grease fire.
- Check the tubes that lead into the burner for any blockage from insects, spiders, or food grease.
- Liquid petroleum (LP) or propane is highly flammable. Treat with care.
- Do not repair gas tanks yourself; seek repair from an authorized repair person.
- Do not repair damaged gas connectors, tank valves, or supply hoses.
- Store gas tanks in an upright, contained, and secure area. Do not leave filled tanks in a hot car or car or car trunk.
- Check for gas leaks. If you detect a leak, immediately turn off the gas and do not attempt to ignite the side burner until the leak is fixed.
- Never light cigarettes or matches, or expose open flames in the presence of a gas leak.
- Do not exceed the power outlet ratings.
- Keep any electrical supply cord and the fuel supply hose away from any heated surfaces.
- To protect against electric shock, do not immerse power cords or plugs in water or other liquids.
- Use outlets that cannot be turned off by a switch or pull chain.
- Do not operate any apparatus or accessories with power plugs missing the ground plug, a damaged cord, or a loose socket. Do not bypass, cut, or remove the grounding plug.
- Unplug the unit if it is not going to be used for an extended period of time.
- Never plug or unplug the unit with wet hands.
- Do not use extension cords or power strips with this unit. You may need to contact your electrician if it is necessary to use a longer cord or if you do not have a grounded outlet. Do not modify the power cord's length or share the outlet with other appliances.
- Do not start or stop the unit by switching the circuit's power on and off.
- If the power cord is damaged, it must be replaced by the manufacturer or a qualified technician.
- Never repair the unit while it is plugged in.
- Immediately unplug the unit if it makes strange sounds, emits smells or smoke comes out of it, and contact customer service.
- You should never attempt to repair the unit yourself. Contact customer service for service options if the unit needs service.
- Never use charcoal or any other non-approved or solid fuel sources. This manual covers side burners fueled by gas (LP and NG) only.



## General Safety

- To prevent back and other types of injuries, use at least two people to move and install the side burner(s) and grilling equipment.
- This appliance is not intended for use by persons, including children, with reduced physical, sensory or mental capabilities, unless they have been given supervision or instruction concerning the use of the appliance by the person(s) responsible for their safety.
- Install the gas side burner(s) in a well-ventilated area.
- Do not place hot or warm items into the cooler before they cool down to room temperature.
- This side burner should not be installed indoors or in a garage, RV, under a carport, etc. Keep away from surfaces that can catch fire.
- This side burner should be installed in a well-ventilated area. It is recommended that it is protected from direct rain, sleet, snow, and / or moisture.
- This side burner is not intended to be used by children.
- Children should be supervised to ensure that they do not play with this product.
- Never allow children to crawl inside the side burner.
- Do not use this appliance near combustibles such as gasoline, benzene, thinner, etc.
- Take care when working with the gas side burner as there will be extremely hot surfaces.
- Only use in an upright position on a flat, level surface and provide proper ventilation.
- Do not pinch or kink the power supply line between the unit and cabinet.
- Do not leave any cleaning solutions in the unit.
- Do not use solvent-based cleaning agents or abrasive solutions to clean the unit as they may damage the interior and exterior.
- Do not place any other appliances on top of the unit.
- Do not turn the unit upside down, on its side or at an angle off level.
- The Consumer Product Safety Commission recommends keeping the side burner at least 10 feet away from your house or any building.
- Maintain all clearance requirements detailed in this user's manual.
- Follow all food safety and handling requirements required by local codes. Do not let food sit [unrefrigerated] for more than one hour before or after cooking.
- Never leave the side burner unattended while cooking.
- Never cook without the drip tray in place.



**Note: This owner's manual is provided for reference use only. Specifications may change without prior notice. Refer to the product label on your side burner for the latest technical information.**



## PROPANE GAS SAFETY

- Your propane gas side burner (models ESB1LP and ESB2LP) is designed to operate on propane gas only at a pressure regulated at 11 inches water column (WC) when equipped with the correct propane orifices on the valves and a propane regulator on the supply line.
- EdgeStar LP side burners are designed to be used with a standard 20 lb. (9.1kg) Department of Transportation (DOT) approved LP cylinder. No tanks larger than 20 lbs. are to be used. The tank must be marked in accordance with the latest DOT specification for LP gas tanks: *Specifications for LP gas Cylinders* (DOT CFR49).
- Burners must be inspected and cleaned before each use.



## Beware of Spiders



Spiders and small insects occasionally spin webs or make nests in the burners during warehousing, transit, and/or after long period of not using the side burner. These webs can lead to a gas flow obstruction, which could result in a fire in and around the burner tubes. This type of fire is known as “flashback” and can cause serious damage to your side burner and create an unsafe operating condition for the side burner user. Although an obstructed burner tube is not the only cause of “flashback,” it is the most common cause. Frequent inspection of the burners is necessary.



## NATURAL GAS SAFETY

- Your natural gas side burner (models ESB1NG and ESB2NG) is designed to operate on natural gas only at a pressure regulated at 4 inches water column (WC) when equipped with the correct natural gas orifices on the valves and a natural gas regulator on the supply line.
- Burners must be inspected and cleaned before each use.



## Beware of Spiders



Spiders and small insects occasionally spin webs or make nests in the burners during warehousing, transit, and/or after long period of not using the side burner. These webs can lead to a gas flow obstruction, which could result in a fire in and around the burner tubes. This type of fire is known as “flashback” and can cause serious damage to your side burner and create an unsafe operating condition for the side burner user. Although an obstructed burner tube is not the only cause of “flashback,” it is the most common cause. Frequent inspection of the burners is necessary.

# Table of Contents

- IMPORTANT SAFETY INFORMATION ..... 1**
- INTRODUCTION .....1**
- PARTS IDENTIFICATION .....2**
- SIDE BURNER DIMENSIONS .....4**
- ISLAND / CABINET CUTOUT DIMENSIONS.....6**
- MAINTAINING ADEQUATE VENTILATION .....7**
- INSTALLING THE GAS SIDE BURNER .....8**
  - TYPES OF INSTALLATION ..... 9
  - LIQUID PROPANE (LP) INSTALLATION AND REQUIREMENTS: ..... 10
  - NATURAL GAS (NG) INSTALLATION AND REQUIREMENTS: ..... 13
- CHECKING FOR GAS LEAKS .....15**
  - ELECTRICAL REQUIREMENTS..... 16
  - PLUGGING IN THE LIGHTS ..... 17
- INCLUDED COOKING COMPONENTS.....18**
  - CHECKING THE IGNITER ..... 18
  - LIGHTING THE BURNER(S)..... 19
- CLEANING AND MAINTENANCE.....21**
  - CLEANING THE BURNER(S)..... 21
  - REINSTALLING THE BURNER(S) ..... 22
  - CLEANING THE COOKING GRIDDLE ..... 23
  - CLEANING THE DRIP TRAY ..... 23
  - EXTERIOR CLEANING ..... 23
  - CARING FOR STAINLESS STEEL ..... 24
- SPECIFICATIONS .....25**
- EDGESTAR LIMITED WARRANTY .....26**

## ***First Time Operating Instructions***

Before use, make sure all packaging labels and materials are all removed from the unit. Be sure to keep track of all included parts and pieces before discarding packaging materials. It is advised that you keep the original box and packaging materials in case you are ever to move or ship the appliance in the future.  
The instruction manual should be read in full before use.

# Introduction

Thank you for purchasing this EdgeStar gas side burner. We hope that this purchase will be the beginning of a lasting and rewarding relationship between you and EdgeStar. We will provide the customer support and exemplary products necessary to nurture that relationship.

This manual contains important information regarding the proper installation, use and maintenance of your gas side burner. Following this manual will ensure that your product will work at its peak performance and efficiency.

Please save the original product packaging in case you need to safely transport your gas side burner.

## For Your Records:

Please write down the model number and serial number below for future reference. Both numbers are located on the ratings label on the back of your unit and are needed to obtain warranty service. You may also want to staple your receipt to this manual as it is the proof of your purchase, and is also needed for service under your warranty.

Model Number: \_\_\_\_\_

Serial Number: \_\_\_\_\_

Date of Purchase: \_\_\_\_\_

For a more efficient experience, please do the following before contacting customer service:

- If you received a damaged product, immediately contact the retailer or dealer that sold you the product.
- Read and follow this instruction manual carefully to help you install, use and maintain your gas side burner.
- Read the troubleshooting section of this manual as it will help you diagnose and solve common issues.
- Visit us on the web at <https://www.edgestar.com> to register your product, download product guides, additional troubleshooting resources and up-to-date information. You can also find an interactive self-diagnostic tool at <https://support.edgestar.com>
- If you need warranty service, our friendly customer service representatives are available via email at **service@edgestar.com** or by telephone at **1 (866) 319-5473**.



# Parts Identification

## ESB1NG / ESB1LP (Single Gas Side Burner)

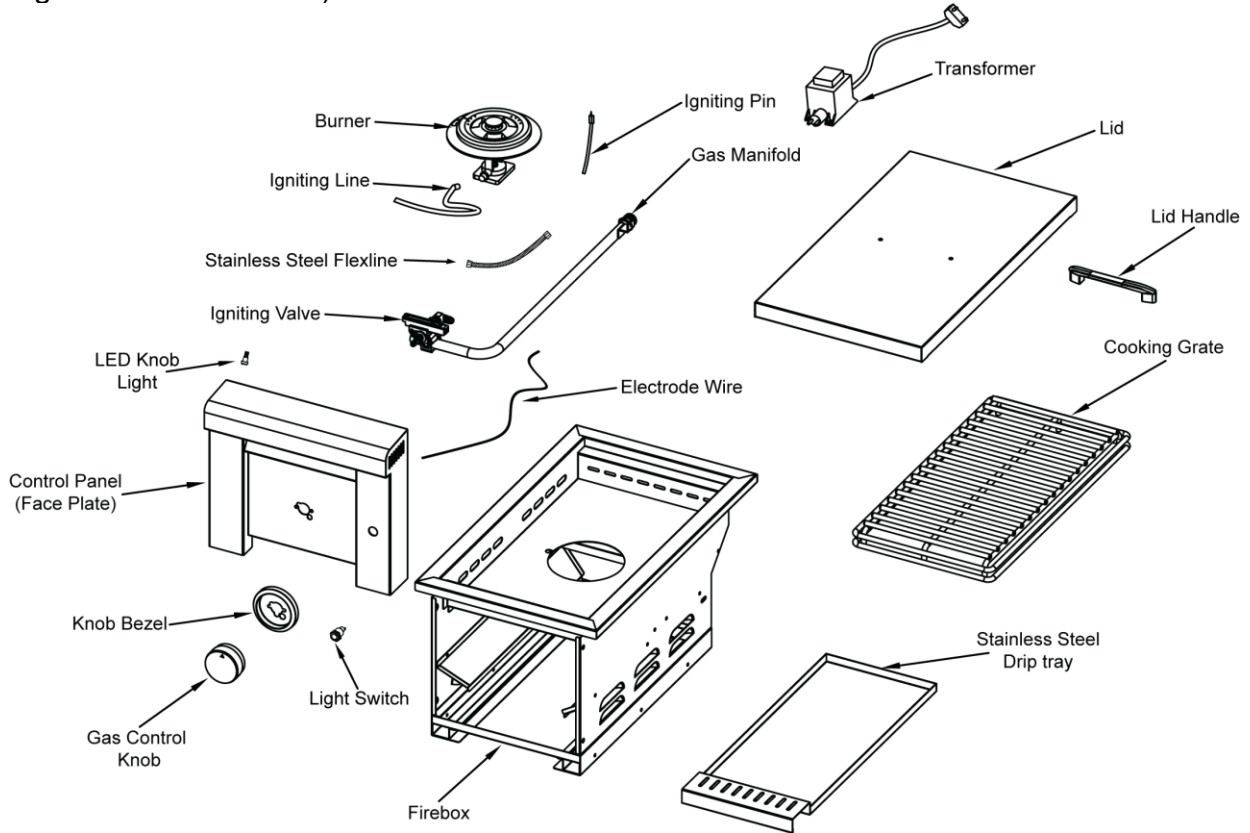

Part Description	Included Quantity
Burner	1
Igniting Line	1
Stainless Steel Flexline (Internal)	1
Igniting Valve	1
Igniting Pin	1
LED Light	1
Control Panel (Face Plate)	1
Gas Control (Burner) Knob	1
Knob Bezel	1
Light Switch	1
Firebox	1
Drip Tray	1
Cooking Grate	1
Lid	1
Lid Handle	1
Gas Manifold	1
Electrode Wire	1
Transformer	1

**ESB2NG / ESB2LP**  
 (Double Side Burner)

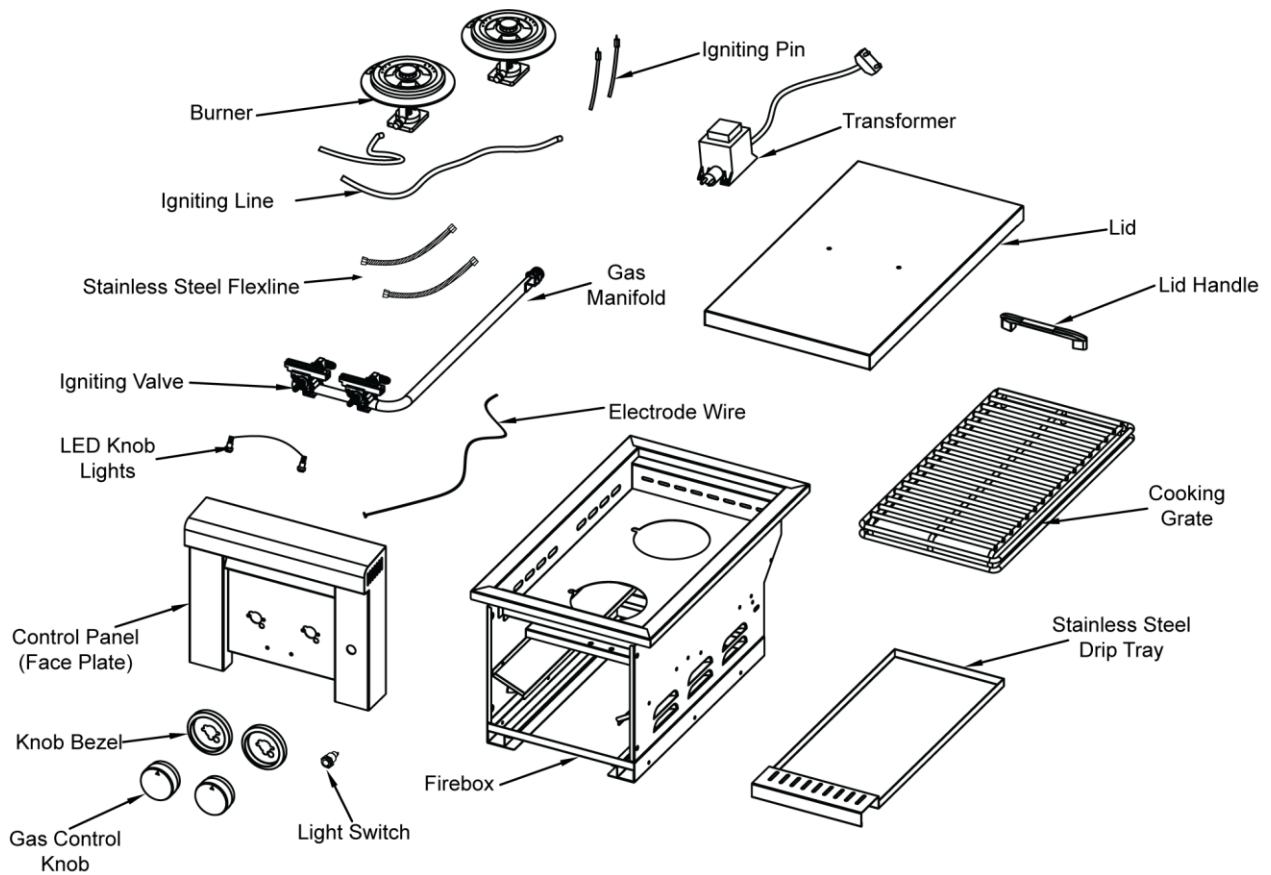

Part Description	Included Quantity
Burner	2
Igniting Line	2
Stainless Steel Flexline (Internal)	2
Igniting Valve	2
Igniting Pin	2
LED Light	2
Control Panel (Face Plate)	1
Gas Control (Burner) Knob	2
Knob Bezel	2
Light Switch	1
Firebox	1
Drip Tray	1
Cooking Grate	1
Lid	1
Lid Handle	1
Gas Manifold	1
Electrode Wire	1
Transformer	1

# Side Burner Dimensions

*ESB1NG / ESB1LP*

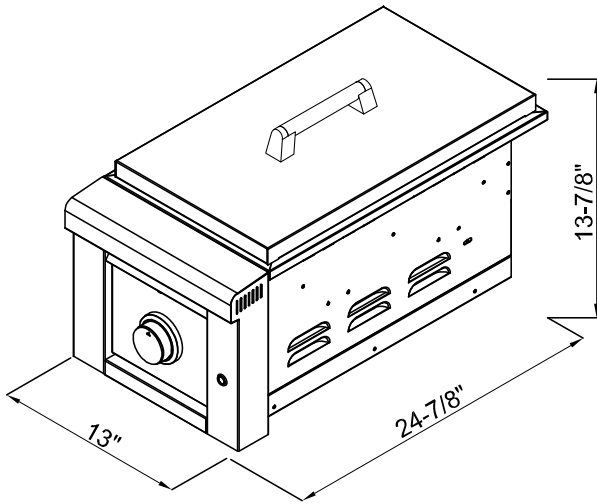

Front

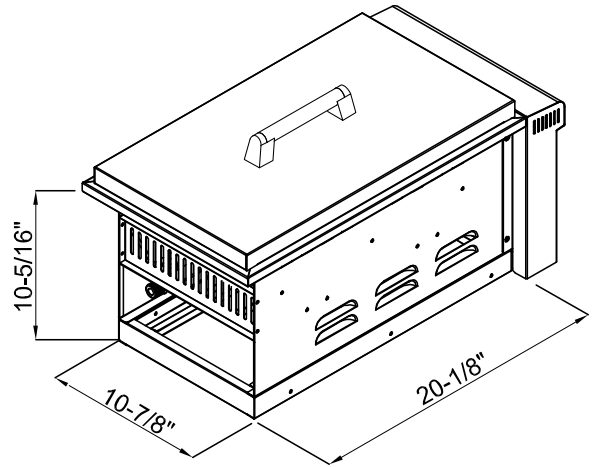

Left

Back

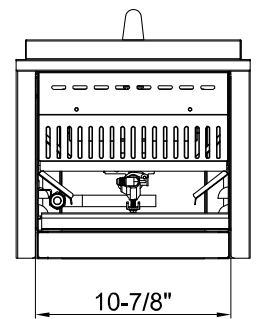
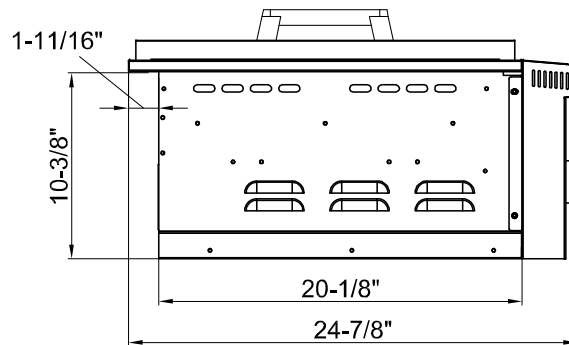
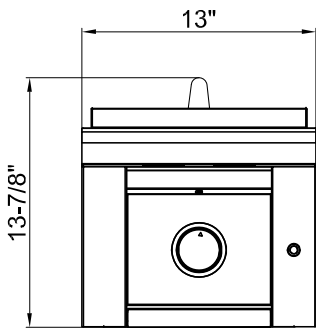

**ESB2NG / ESB2LP**

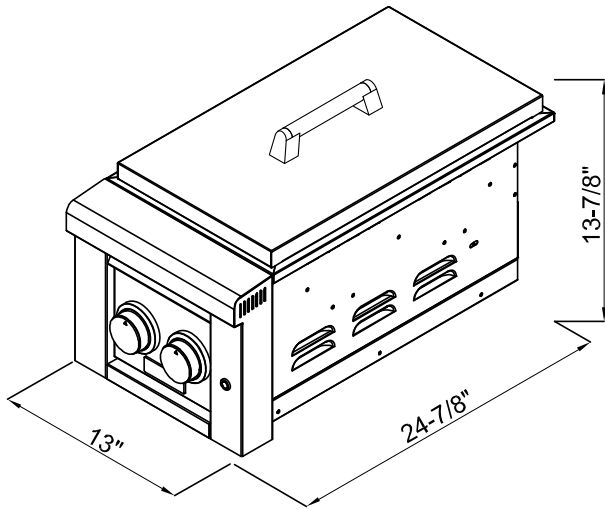

Front

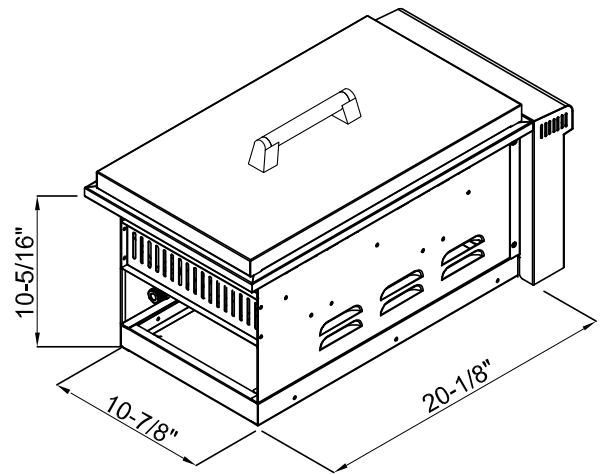

Left

Back

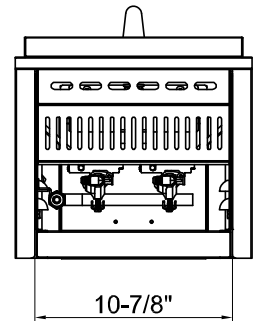
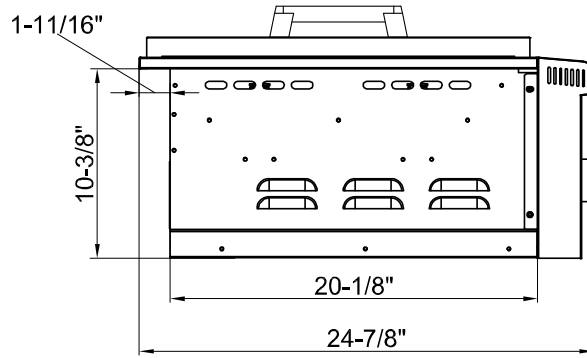
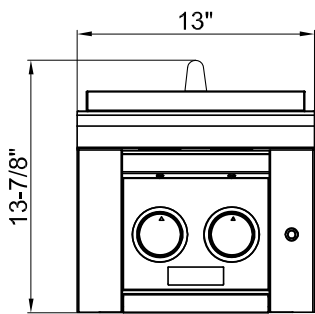

# Island / Cabinet Cutout Dimensions

- Do not store extra propane or butane tanks in proximity to your gas side burner.
- All BBQ islands must be manufactured from non-combustible material(s).
- Minimum clearance to combustible construction material(s) is 24" from the back and sides.
- Built-in islands and cabinets must be equipped with vents to allow for proper ventilation and combustion.
- For your safety, one side of the enclosure must be left completely open or there must be a minimum of four (4) ventilation openings.
  - The openings must all be the exact same size.
  - The openings must each have a minimum of 10 square inches surface area.
  - The top openings must be spaced so that the top of each opening is one inch or less from the countertop. The opening must not extend beyond five inches below the counter surface.
  - The bottom openings must be spaced so that the bottom of each opening is one inch or less from the floor. The opening must not extend beyond five inches above the floor.
- Vents should have screens to prevent animals, critters, and foreign objects from entering the cabinet.
- Vents must not be obstructed in any way to allow for proper ventilation and cross-flow.

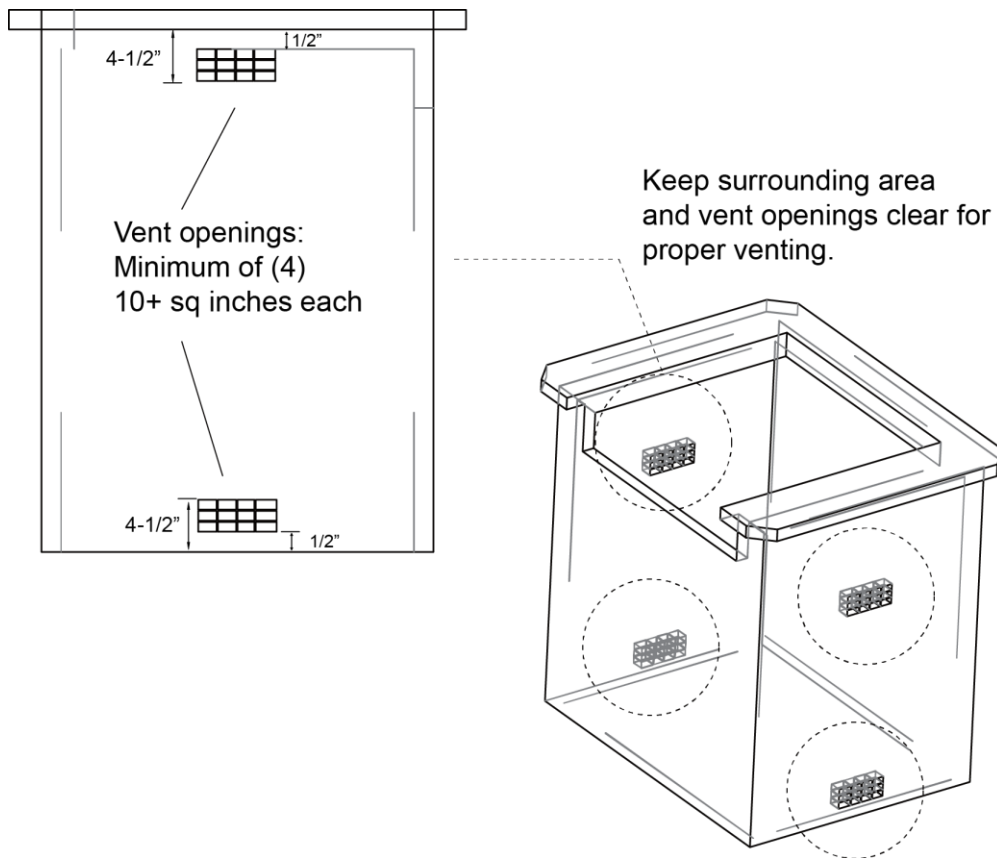

## Cabinet Opening

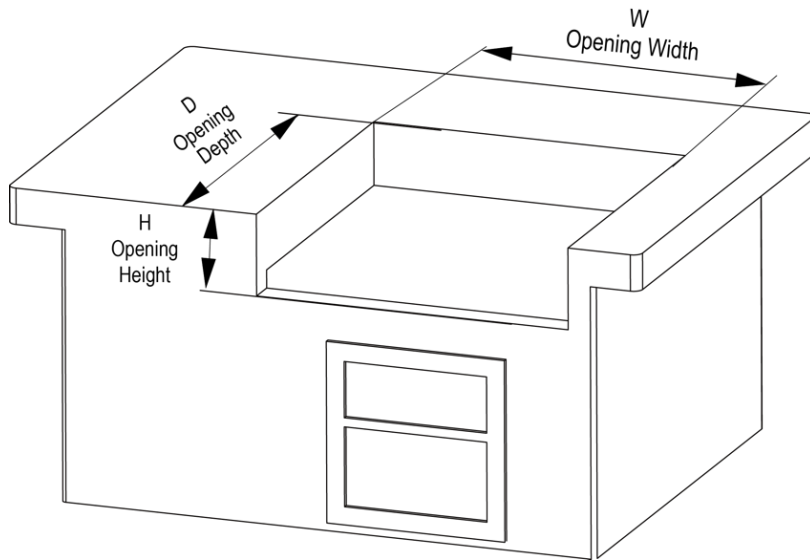

Model	Opening Width (W)	Opening Depth (D)	Opening Height (H)
ESB1 Series	10-7/8"	20-1/8"	10-3/8"
ESB2 Series	10-7/8"	20-1/8"	10-3/8"

## Maintaining Adequate Ventilation

When building a gas side burner into outdoor cabinetry or an island, it is important to maintain proper ventilation. Ventilation is required to prevent the build-up of gas, which could ultimately lead to improper performance of the gas side burner; damage to the side burner; fire, explosion, or injury to the user. Always make sure that there is proper ventilation and that all flammable materials are placed at least 24 inches away from the side burner on all side.

Be sure to clean the side burner vents of all dirt, debris, insects, and spider webs.

Additionally, the side burner functions best when protected from outdoor elements. The side burner should be placed in a location that does not get direct rainfall. Wind can greatly affect the performance of any gas side burner. Be advised that it can affect the ability of the side burner to maintain a flame. When substantial wind enters the rear exhaust of the side burner, it can create a gas build-up, which poses a fire risk.

## Unpacking the Gas Side Burner



**WARNING:** Use two more people to move and install the gas side burner. Failure to do so can result in back or other injury. Carefully remove the packaging materials. Remove any shipping tape and glue from your gas side burner before using. Do not use sharp instruments, rubbing alcohol, flammable fluids, or abrasive cleaners to remove tape or glue. These products can damage the surface of your gas side burner.



**IMPORTANT:** Do not remove any safety, warning, or product information labels from your gas side burner.

Check the rating label on your side burner to ensure that the fuel source is appropriate for your application *before* trying to connect any gas lines.

## Installing the Gas Side Burner



**Tip:** Gather the model and serial number from the product label and write them down before installing the gas side burner(s).

### Notes About Installation

- The gas side burner should be installed in accordance with all local code requirements in addition to the *National Fuel Gas Code*, ANSI Z223.1 / NFPA 54.
- **Installation by a professional is highly recommended** for proper placement and functionality.
  - In the state of Massachusetts, installation and repairs **MUST** be performed by a qualified or licensed contractor, plumber, or gas fitter qualified or licensed by the State of Massachusetts.
- This gas side burner is not intended to be installed in or on boats or recreational vehicles (RVs).
- Make sure that there are no kinks and no twisting in gas supply hoses.

## ***Installation Location***

- Ensure the gas side burner is positioned safely away from anything that can catch fire. Under no circumstances should this gas side burner be installed indoors or in a garage. Additionally, it should not be located under a carport, in a work shop, etc.
- The gas side burner should also be placed in a location that is strong enough to support its total weight. A firm level surface is required.
- Do not install the gas side burner within 24 inches of wood stockpiles, gyprock, paper, or plants. Place the side burner in an area where it can have a minimum of 24 inches clearance from combustible materials, including gasoline, flammable liquids or flammable vapors.
- Adequate ventilation must be maintained for the side burner to function properly. This will ensure gas does not build up.
- Keep the side burner protected from inclement weather conditions, including direct rain and high winds.
- Once the gas side burner is installed, you must still be able to access the gas supply line, regulator, gas cylinder, and shut off valves.

## ***Types of Installation***

This manual covers an EdgeStar gas side burner series that includes models using either a Liquid Propane (LP) or a Natural Gas (NG) fuel source. Select your appropriate fuel type and follow the relevant installation instructions, as follows.

In each case, there must be adequate ventilation and access for service.



**WARNING: Inspect all gas tanks, gas supply hoses, and regulators each time you connect or disconnect the fuel source. Always turn off the gas supply when the gas side burner is not in use.**



## Liquid Propane (LP) Installation and Requirements:

- Side burners operated with LP fuel must be installed with the supplied LP regulator.
- EdgeStar LP side burners are designed to be used with a standard 20 lb. Department of Transportation (DOT) approved LP tank. No tanks larger than 20 lbs. are to be used. The tank must be marked in accordance with the latest DOT specification for LP gas tanks: *Specifications for LP gas Cylinders* (DOT CFR49).
- LP tanks must come with a protective collar to guard the cylinder threads.
- The standard fitting connection for LP tanks is 3/8".
- LP tanks must be filled by a qualified professional and must not ever be overfilled.
- An Overfill Prevention Device (ODP) must be used at all times.
  - This side burner is to be used in residential applications only. Propane tank pressure should be 11 inches water column.
- When using an LP tank, pressure relief devices and valves shall be in direct contact with the vapor space of the cylinder when in normal use.
- LP tanks must always be secured and anchored in an upright position when in use. An LP tank base and retention bolt must be used (not included).

LP Gas Tank Retention  
(Top-down view)

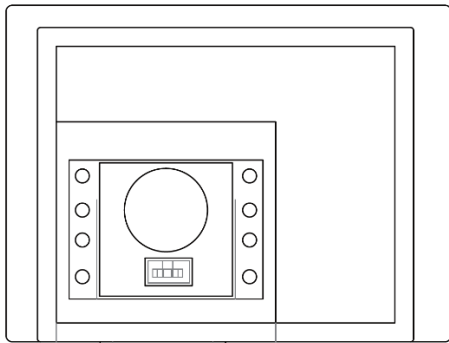

LP Tank Base

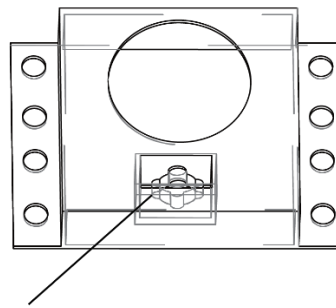

LP Tank Retention Bolt

The LP tank base should be fastened securely to the bottom of the island / cabinet using a combination of bolts, washers, and nuts. Ensure that a minimum of 2" of clearance is maintained between the floor and the LP cylinder. Once the LP tank base is secured, place the primary LP tank in place and tighten the retention bolt until the tank is snug.

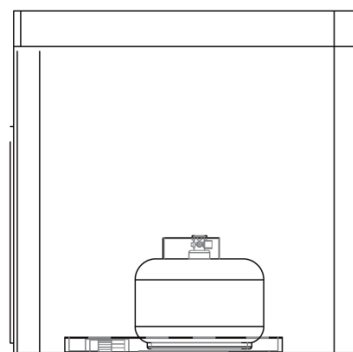
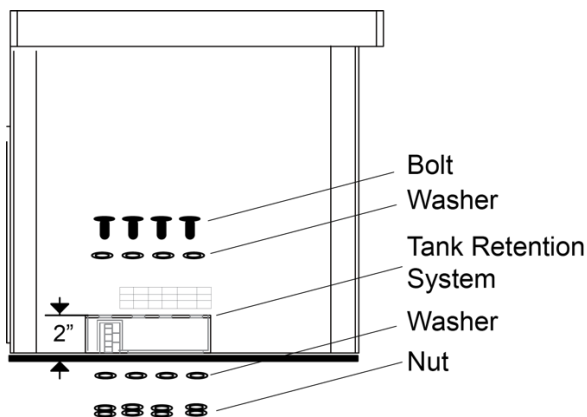

## To Connect the LP Gas Supply:

1. Ensure the 20 lb. LP tank valve is fully closed. To do so, make sure the tank handle is turned all the way clockwise. You should not hear a hissing noise or smell propane.
2. All gas control (burner) knobs must be in the off position.
3. Align the 3/8" brass coupling nut with the LP tank threads; turn the coupling nut clockwise by hand. Note that the fittings have flared ends and do not require any modifications or sealant. **Do not overtighten the coupling nut connection** as it may cause damage or strip the threading.

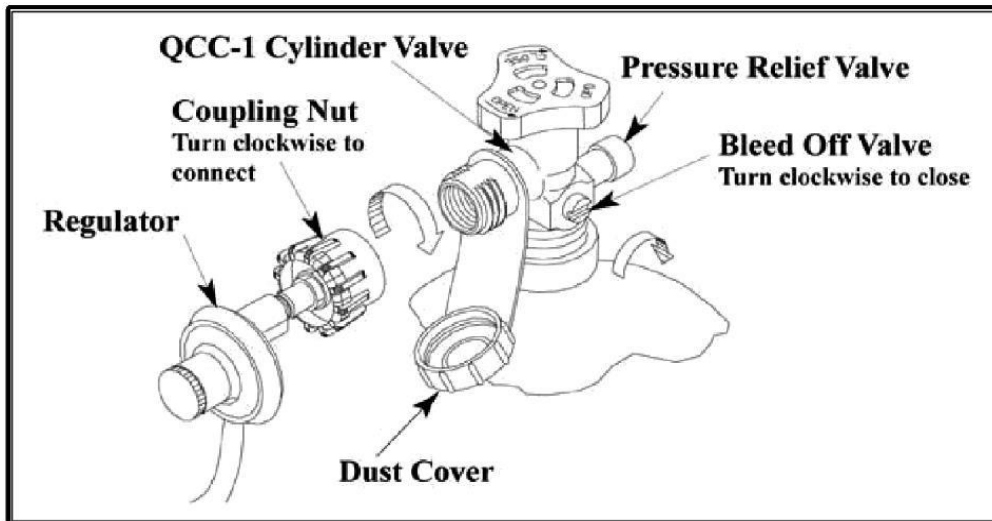

4. Open the LP tank valve by turning the handle counterclockwise.
5. Using a soapy water mixture in a spray bottle, check for leaks at all joints and connection points. Bubbles should not form in the soapy water mixture. See the section titled, "**Checking for Gas Leaks**" in this manual for further instructions and details.

Remember to test after every LP tank refill or replacement

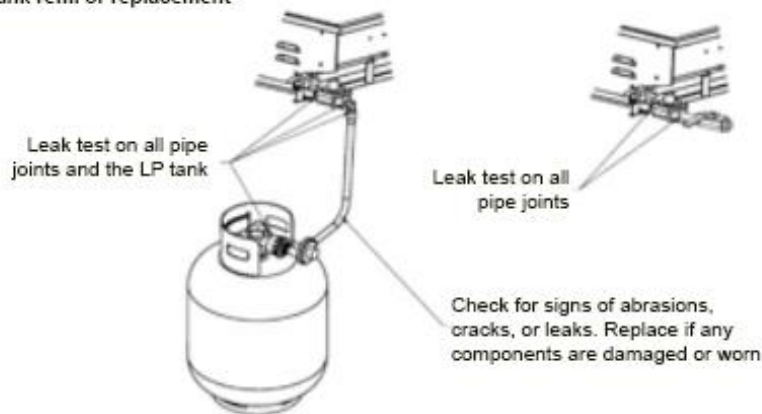

6. Once you have confirmed that all connections are secure and there are no gas leaks, you may proceed with normal use of your side burner. All connection points must be free from gas leaks before first use of the gas side burner.
7. A reminder to always close the LP tank valve [by turning the handle clockwise] when the side burner is not in use.

### Using an LP Gas Supply in an Enclosure:

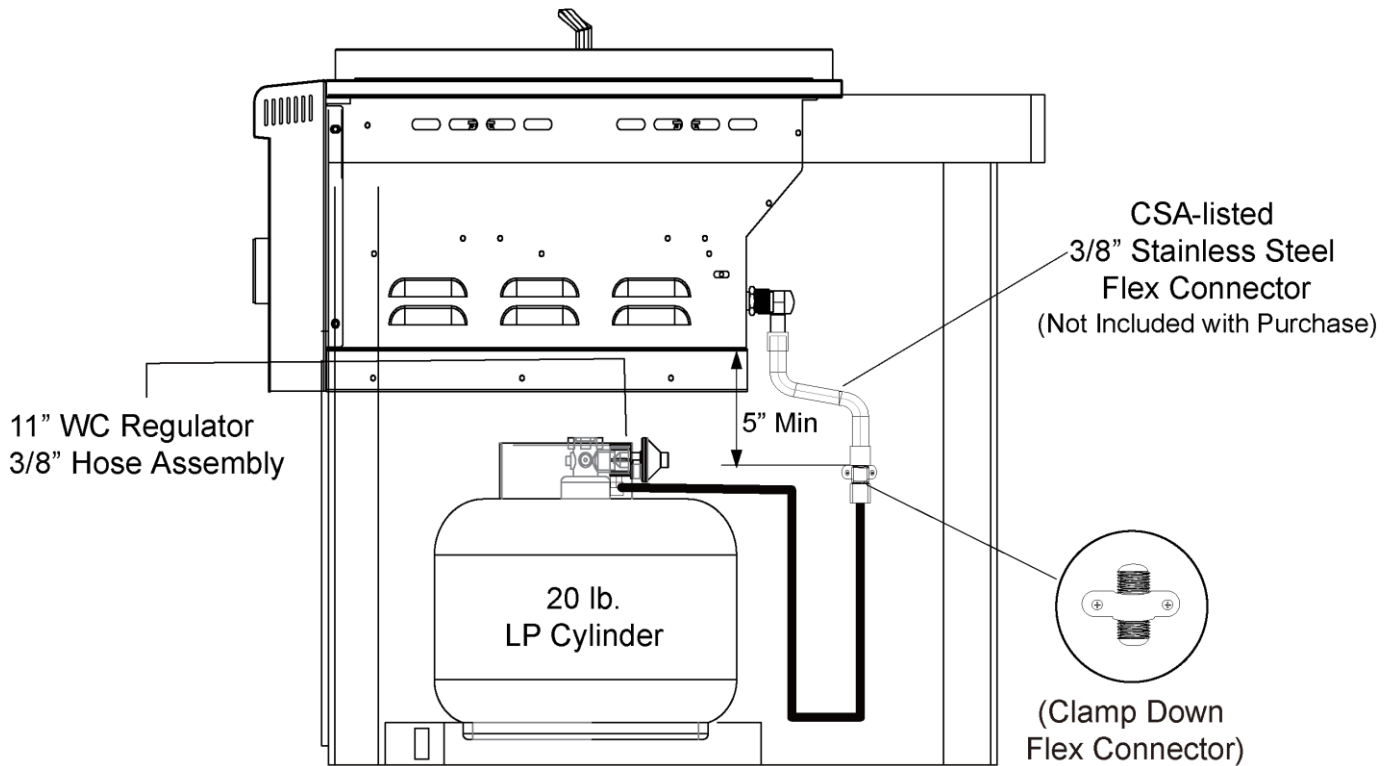

## ***Natural Gas (NG) Installation and Requirements:***

- Ensure that the natural gas supply line is fitted with a shut-off valve that can be easily accessed in the event that shutoff at the source is required.
- Side burners operated with NG fuel must be installed with the NG regulator supplied with your EdgeStar side burner.
- EdgeStar NG side burners are equipped with an NG regulator set to 4 inches water column. This regulator is for NG only.
- The standard fitting connector for an NG supply is 1/2".
- Use a quality natural gas flex connector (not included) to mate to the included NG regulator. CSA, UL, or ETL certified connecting lines are recommended. Stainless steel flex connectors are also recommended.
- The flex connector should be an appropriate length for your setup. Do not use a connector that is too short and requires you to stretch it too far to make the connection.
- Flex connectors should come with a standard 1/2" connection for NG fittings.
- Flex connectors should be placed carefully in a location where they are not at risk of being cut, punctured, or kinked.
- Yellow Teflon pipe thread sealant (PTFE tape) is recommended for use on all pipe thread connections with the exception of flared threads, which will have a secure connection.

### **To Connect the NG Gas Supply:**

1. Ensure the NG shut-off valve is fully closed. You should not hear a hissing noise or smell natural gas.
2. All gas control (burner) knobs must be in the off position.
3. Fasten the 1/2" flex connector – already installed to the NG supply shut-off valve – to the included NG regulator. Use Yellow Teflon pipe thread sealant (PTFE tape) for non-flared connections. No sealant is required for flared connections. **Do not overtighten the regulator connection** as it may cause damage or strip the threading.
4. Open the NG shut-off valve.
5. Using a soapy water mixture in a spray bottle, check for leaks at all joints and connection points. Bubbles should not form in the soapy water mixture. See the section titled, "**Checking for Gas Leaks**" in this manual for further instructions and details.
6. Once you have confirmed that all connections are secure and there are no gas leaks, you may proceed with normal use of your side burner. All connection points must be free from gas leaks before first use of the gas side burner.
7. A reminder to always close the shut-off valve when the side burner is not in use.

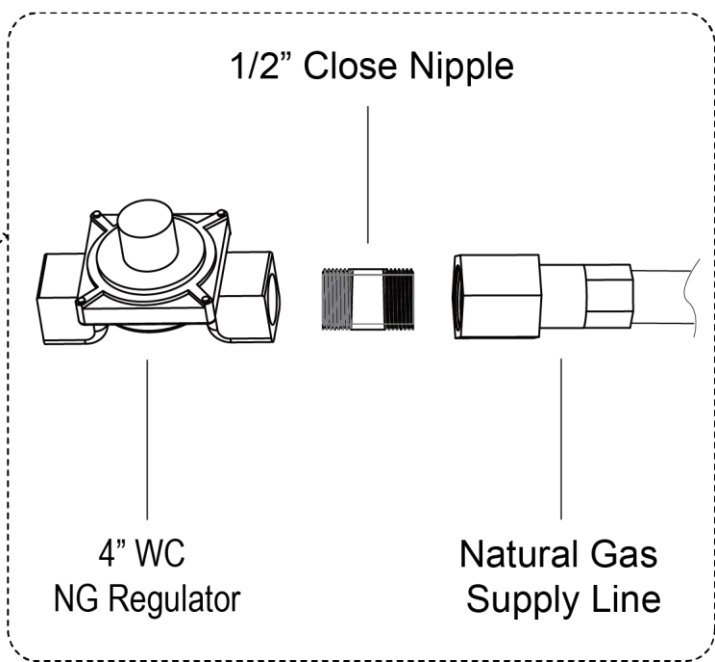
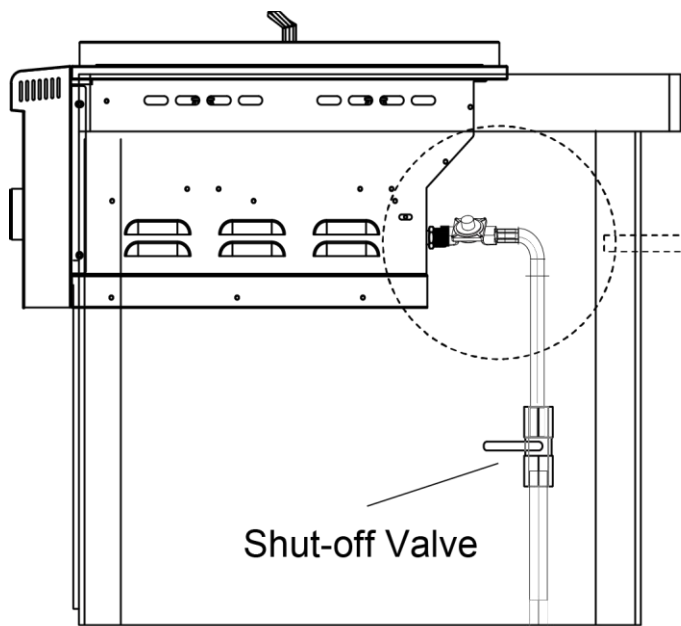
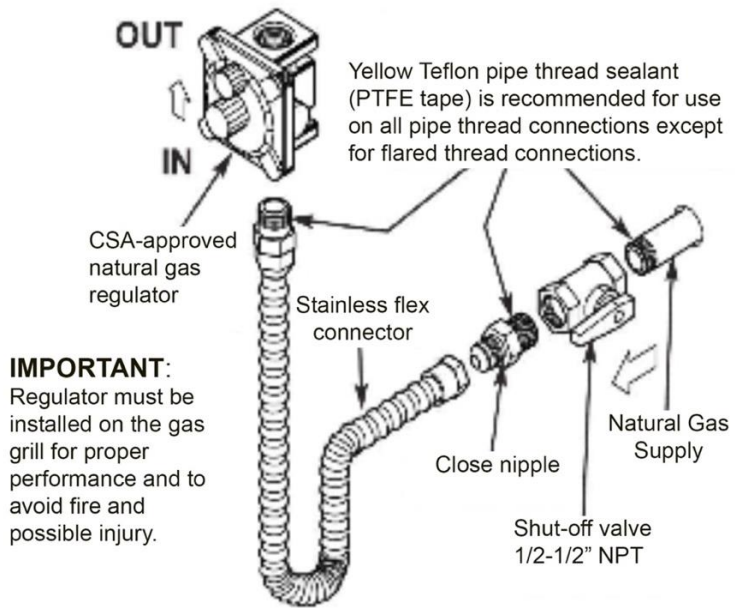

## Checking for Gas Leaks

At least once every six months, and any time a tank is disconnected and reconnected, perform a leak test. Additionally, any time any components including the gas supply lines or the regulator are replaced, perform a leak test. Never use the side burner without testing for gas leaks first.



**WARNING:** Do not test for gas leaks with an open flame. When testing for leaks, make sure all gas control knobs are in the off position.

To perform the leak test:

- Create a mixture of soapy water that is one part soap to one part water. Place the solution in a spray bottle.
- Turn the gas on – again, ensuring that the gas control knobs of your side burner are off.
  - On Natural Gas (NG) systems, turn the on the gas supply's main feed valve and make sure the shut-off valve is open.
  - On Liquid Propane (LP) systems, turn the cylinder knob counterclockwise to open.
- Spray the soapy water mixture on the joints of the gas delivery system. If you see blowing bubbles, there is a leak present, which needs to be fixed prior to operating your side burner.

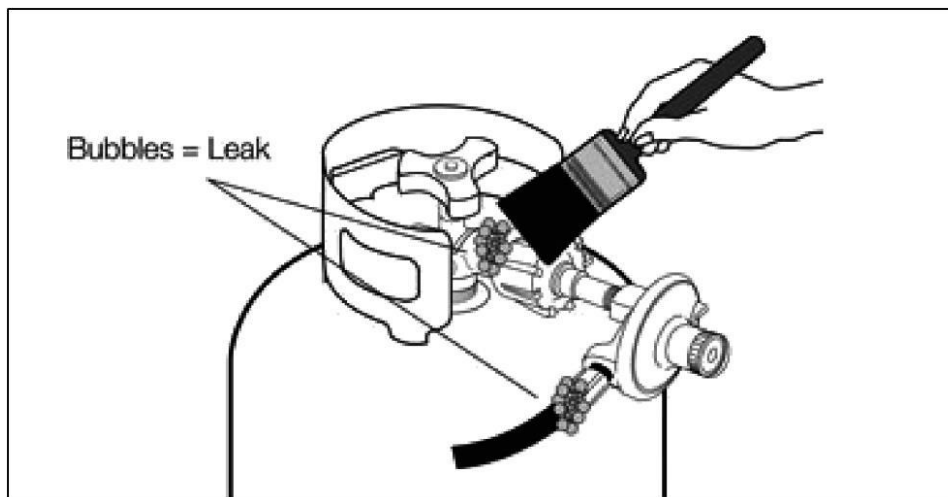

## ***Electrical Requirements***



### **ELECTRIC SHOCK HAZARD!**

- **Plug into a grounded 3-prong outlet.**
- **Never remove the grounding prong from the plug.**
- **Never use an adapter to bypass the grounding prong.**
- **DO NOT use an extension cord.**
- **Failure to follow these instructions can result in fire, electrical shock, or death.**

Before you install your gas grill into its final location, it is important to make sure you have the proper electrical connection. A standard electrical supply (115V AC, 60Hz), properly grounded in accordance with the National Electrical Code and local codes and ordinances, is required. Check with a qualified electrician if you are not sure whether or not your electrical connection is properly grounded.

The fuse (or circuit breaker) size must be 15 Amps. It should be a GFI breaker suitable for outdoor use. It is recommended that a separate circuit be provided. Use receptacles that cannot be turned off by a switch or pull chain.

If permitted by national and local codes, and the installation requires a separate ground wire, a qualified electrician must determine the appropriate ground path.

In addition to the above, always observe the below warnings:

- To protect against electric shock, do not immerse cord or plugs in water or other liquid.
- Unplug from the outlet when not in use and before cleaning. Allow to cool before putting on or taking off parts.
- Do not operate any outdoor cooking gas appliance with a damaged cord, damaged plug, or after the appliance malfunctions or has been damaged in any manner. Contact EdgeStar for repair.
- Do not let the cord hang over the edge of a table or touch hot surfaces.
- Do not use an outdoor cooking gas appliance for purposes other than intended.
- When connecting, first connect the plug to the outdoor cooking gas appliance. Then, plug the appliance into the outlet.
- Use only a Ground Fault Interrupter (GFI) protected circuit with this outdoor cooking gas appliance.
- Use extension cords with a 3-prong grounding plug rated for the power of the equipment and approved for outdoor use with a “W-A” marking.

## Recommended Grounding Method

For your personal safety, this appliance must be grounded. It is equipped with a power supply cord having a 3-prong grounding plug. To minimize possible shock hazard, the cord must be plugged into a mating 3-pronged wall socket, and grounded in accordance with the National Electrical Code and local codes and ordinances. If a mating wall socket is not available, it is the personal responsibility of the customer to have a properly grounded, 3-prong wall receptacle installed by a qualified electrician.

Disconnect the electrical components from the power supply by removing the power plug from the wall socket.



### **Warning:**

- Do not touch the power plug when your hands are wet.
- Never unplug the unit by pulling on the plug.

## Plugging in the Lights

This EdgeStar series of gas side burner includes stylish and functional backlighting for the knobs and switches. These lights require a 120V AC power supply to function. Please review the electrical requirements in this manual carefully.

Connecting the lights is a simply plug-and-play procedure. The included transformer (packed separately) comes with a 3-prong 120V AC plug. The side burner has a 2-prong connecting wire pre-attached (reference the *Parts Identification* section of this manual). Plug the 2-prong wire into the transformer. Ensure that the connection is secure.

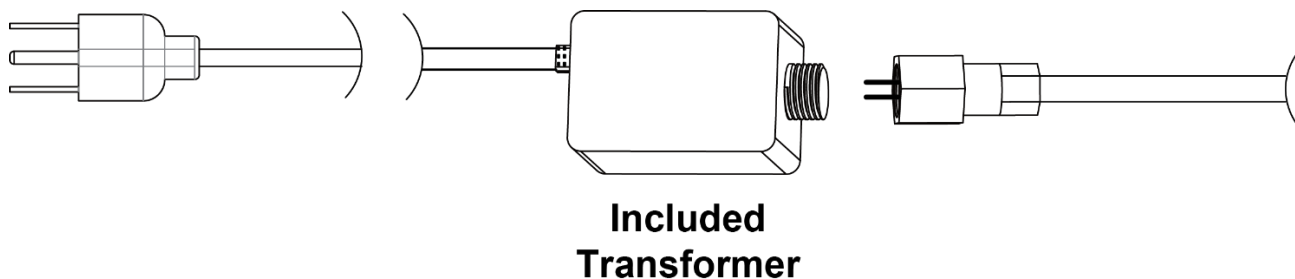



## Included Cooking Components

Before using the EdgeStar gas side burner for the first time, be sure to thoroughly wash [by hand] the included cooking griddle under hot water with soap. **Do not wash in your dishwasher.** Allow it to dry before reinstalling in the side burner.

## Operation



**Important:** You must always have the side burner lid removed when lighting the gas side burner. Otherwise, you risk build-up of gas and possible fire or explosion.



**Important:** To avoid risk of injury, always keep your face and body as far away as possible from the side burner when lighting. As you proceed to operate the side burner, note that surfaces may be hot and pose a burn hazard. Take care around the side burner and make sure to never leave it unattended. Children should not operate the side burner.

For an optimal grilling experience, this EdgeStar series of gas side burners includes a combination of infrared burners and cast burners, referred to hereafter as “main burner(s).” Additionally, this EdgeStar side burner series comes standard with a rotisserie burner. Instructions for using these burners are in the following sections.



**Important:** Once the burner(s) are lit, leave them on the “HIGH” setting for five minutes before cooking anything. This will allow the side burner to preheat and burn off any foreign matters or food objects left on the side burner.

### ***Checking the Igniter***

With gas turned off at the source, and with each of the burner control knobs in the “OFF” position, you can check to see that the igniter is working properly. Push the burner knob in fully and turn it counterclockwise a quarter turn to the “HIGH” position. You should see a blue spark at the end of the igniter pin. If you have a two burner side burner, repeat for the other burner. Once you confirm that the igniters work, turn the control knobs clockwise back to the “OFF” position.

## ***Lighting the Burner(s)***

**Tip: If you have never used the side burner before, or have not used the side burner for an extended period of time, it may take multiple attempts to light the burner(s).**

1. Make sure you have observed all safety warnings in this manual. Follow the instructions for connecting the gas supply. NEVER turn on the side burner without testing for leaks first. Keep all body parts as far away from the side burner as possible. Never smoke while lighting the side burner.
2. Remove the lid and place to the side.
3. With all gas control (burner) knobs in the “OFF” position, open the gas supply.
4. For each burner you wish to operate, push the gas control (burner) knob in, and rotate counterclockwise a quarter turn to the “HIGH” position marking on the knob. Turn the knob slowly so as to allow enough gas to reside in the lines to successfully ignite the burner.
5. The burner should ignite. Repeat for the other burner, if applicable.
6. Allow burners to run on “HIGH” for a few minutes so they can burn off extra gas and residue. Then, proceed to adjust the burner knobs to your desired cooking temperature.
7. Once you are done using the side burner, push the burner knob(s) in, and rotate clockwise to the “OFF” position. You may hear a popping sound when the burners are turned off, which is normal.
8. Immediately turn off your gas supply.

### *If a burner fails to light:*

1. If a burner does not light on the first try, repeat immediately. On your second attempt, if the burner does not light within five (5) seconds, turn the burner knob(s) completely off. Do not try again for a minimum of five (5) minutes as the gas dissipates.
2. After five (5) minutes, you may proceed to try to light the burner again using the procedures outlined above.
3. Once you successfully light the first burner, you may proceed to light the other burner(s), as needed.
4. If, after a few rounds of trying to light the burner, the burner still does not light turn all knobs to the “OFF” position and cut the gas supply at its source.
5. Inspect for proper setup and look for any obstructions to the gas supply that may be causing the issue. Additionally, inspect the burner ports for any blockages.

“Flashback” may occur in or around the burner tubes. Flashback is commonly recognized by a “whooshing” sound. If this occurs, immediately turn off all burners and shut off the gas supply to the side burner. Allow grilling components to cool fully before handling them. Remove the burners and brush them with a soapy water mixture to rid them of all foreign materials, dirt, debris, and food waste. Only reinstall them after they have been thoroughly cleaned. To mitigate flashback, clean the burners monthly and any time you use the side burner after an extended period of time.

## Manually Lighting the Burner(s)



**Important:** If you have tried lighting your burners to no avail, wait at least five (5) minutes before manually lighting the burners. Leave the lid off of the side burner to allow gas to dissipate to avoid a possible hazard.

1. Make sure you have observed all safety warnings in this manual. Follow the instructions for connecting the gas supply. NEVER turn on the grill without testing for leaks first. Keep all body parts as far away from the side burner as possible. Do not lean over the grill.
2. Follow steps 1-4 in the “*Lighting the Burner(s)*” section of the previous page.
3. Remove the griddle.
4. You may then use a long fireplace-style of match to manually light the burners. Place the flame near the burner ports and the burner should light immediately. Make sure to keep all body parts as far away from the side burner as possible during the process.
5. Replace the griddle and adjust the burner(s) to your desired cooking temperature.



### **Caution:**

- Do not leave the side burner unattended while it is in use.
- Do not attempt to move the side burner while it is in use.
- Do not disconnect the gas supply while the side burner is in use.
- Turn the gas supply off after you are done using the side burner.
- If you are unable to manually light your burners after several attempts, turn off the gas and contact EdgeStar service or an authorized technician.

## Flare-Ups

Flare-ups can occur when fats and oils drip from the contents being grilled down onto the burners. Flare-ups can be a good thing, imparting a fire/smoke-infused flavor into the contents being grilled. However, if flare-ups become excessive, turn the gas to a lower setting.



### **Caution:**

- If a grease fire occurs, do NOT use water to attempt to put it out. Turn all burners off and close the lid. If the fire persists, use an ABC extinguisher.
- If the burners go out during operation, turn off all burner knobs and shut the gas valve at its source. Keep the lid open for at least five minutes with the gas supply off before attempting to re-light the burners. Do not touch the cooking grates or any internal parts of the side burner as they may burn you.

# Cleaning and Maintenance



**Caution:** Always ensure that the gas supply is fully turned off prior to performing any cleaning and maintenance on your side burner. All burner knobs should also be in the “OFF” position. Never attempt to clean parts of the side burner while they are still hot.



**Caution:**

- For proper functionality, use pots that are between 4-3/4” and 8-3/4” in diameter.
- Allow the side burner to heat up to appropriate temperatures before attempting to cook foods, particularly those that are unsafe to consume unless they reach a minimum internal temperature.



**WARNING:**

- Do not line the drip tray with aluminum foil as this poses a fire risk.

Periodic cleaning and proper maintenance will ensure efficiency, top performance, and long life. Additionally, proper preventive maintenance is required for your own safety.

- Use a pipe cleaner or wire to clear any blockages in the tubes that lead into the burner(s). Examples of blockages include food grease, outdoor debris, and residue from insects.
- Keep your outdoor grill and side burner area clear and free from combustible materials, gasoline, and other flammable vapors and liquids.
- Do not obstruct the flow of combustion and ventilation air. Keep all objects away from vents.

## ***Cleaning the Burner(s)***



**Tip:** After every use of your side burner, once you are done, turn the burners to the HIGH setting for up to five (5) minutes to burn off food residue, drippings, and grease. Do NOT leave the burners on for more than five minutes and do not leave the side burner unattended during this time.

1. After ensuring that the gas is shut off and the burner is cool to handle, remove the burner from the firebox. First, make sure to disconnect the ignition wires.

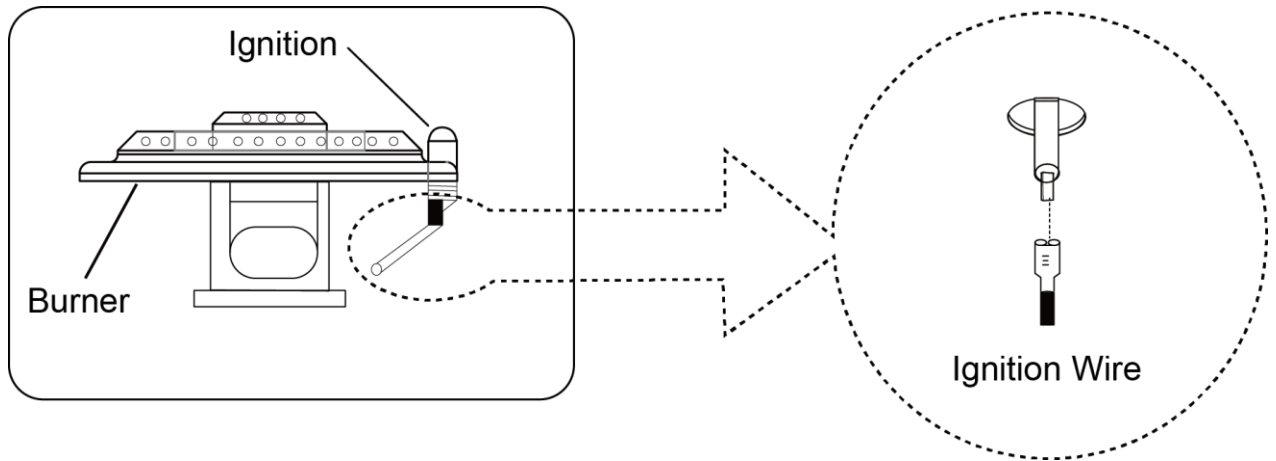

2. Use a bristled brush and run it through the orifices of the burner several times.
3. Go over the exterior of the burner with a wire brush several times to loosen debris and residue. You may also wipe it with a terry cloth or damp rag without using any chemicals. For stubborn scale, you may use a scraper.
4. Look at all burner ports (the small openings) and run a pipe cleaner or thin wire through them.

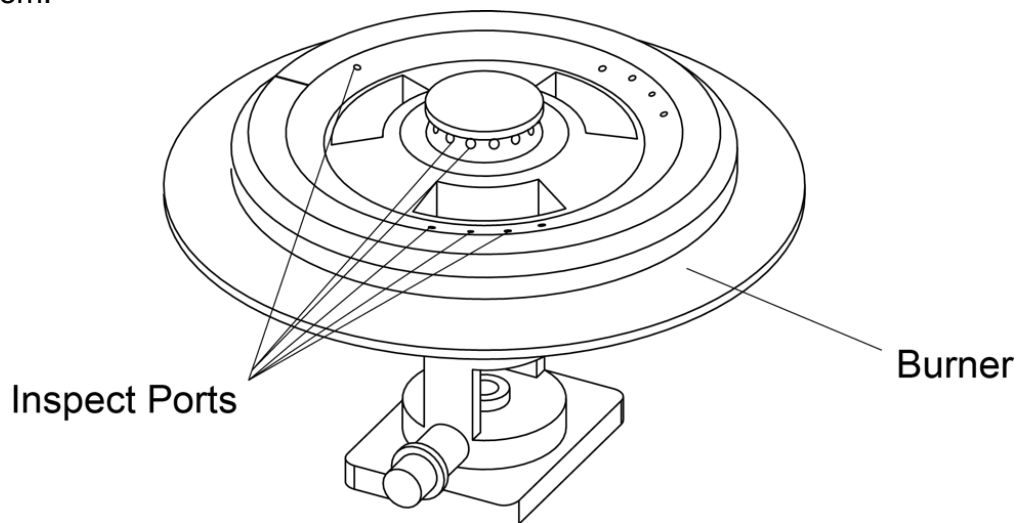

5. Analyze the burner for corrosion and any damage caused by corrosion.

### ***Reinstalling the Burner(s)***

1. Ensure that the gas is shut off prior to attempting to reinstall each burner.
2. Carefully reinstall the burner back into the firebox.
3. Check that the burner is firmly in place in its proper location after replacing. Make sure the tubes on the bottom of the burner are inside the venturi tube opening (see below). These tubes **MUST** be seated inside the venturi tube opening; if not, gas will escape and there is a risk for fire or explosion.
4. Reconnect the ignition wires.

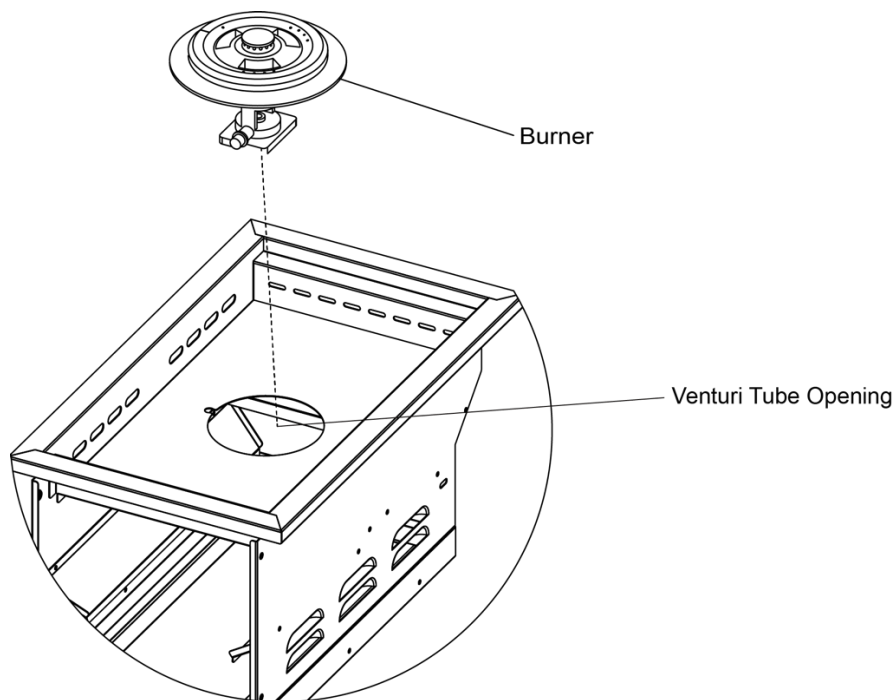

### ***Cleaning the Cooking Griddle***

After using the side burner, turn the burner knob(s) off and cut the gas at its source. Once the side burner and griddles have cooled down, remove the griddle and clean it with a soap and water mixture. You may use a terry cloth to wipe down the cooking griddle. Reinstall once the griddle is fully dry and cover with the side burner lid.

### ***Cleaning the Drip Tray***

The removable drip tray will collect grease as you use your side burner. Inspect the drip tray frequently to ensure that grease and debris do not build up. The drip tray can be wiped with a warm soapy water mixture and a terry cloth. Use a wire brush, if necessary, to loosen hardened grease.



**Warning: Grease build-up poses a fire hazard. Clean the drip tray regularly.**

### ***Exterior Cleaning***

The stainless steel side burner exterior may be cleaned with a mild detergent and lukewarm water solution such as two tablespoons of baking soda to one quart of water.

Do not use solvent based or abrasive cleaners. Use a soft sponge and rinse with clean water. Wipe with a soft clean towel to prevent water spotting. Stainless steel can discolor when exposed to chlorine gas and moisture. Clean stainless steel with a cloth dampened with a mild detergent and warm water solution. Never use an abrasive or caustic cleaning agent. Maintenance of your stainless steel side burner is important to extend the life of your side burner. Stainless steel can and will rust and corrode if not cleaned properly and regularly.

## ***Caring for Stainless Steel***

Side burners near swimming pools, high humidity areas, and coastal areas are particularly susceptible to stainless steel rusting. Moisture, high heat, salt / salt water, and chlorine in particular can cause damage. Your EdgeStar side burner is constructed using high quality stainless steel, but take extra precautions to maintain the quality aesthetic and well-being of your side burner. Additional steps for caring for your stainless steel side burner are below:

- Clean up all grease spills and foreign materials that adhere to your side burner as soon as possible.
- If using household cleaners made specifically for stainless steel, take care to wipe in the same direction as the graining / brushing of the stainless steel.
- When cleaning the area around your side burner – floors, cabinetry, other appliances – take care to protect your side burner when using other abrasive cleaning materials and sealants. Do not let these materials come into contact with your side burner. If they do, clean them immediately with a warm soapy water mixture.
- If possible, use a cover designed for side burners to shelter your side burner from the elements. However, make sure the side burner is not still hot or wet before covering the side burner.

# Specifications



Note: Technical data and performance information are provided for reference only.

Model Number	ESB1**	ESB2**
Total Input (Burner BTUs)	13,000	26,000
Number of Burners	1	2
Stainless Grade	304	304
Width (Inches)	13"	13"

Specifications are subject to change. Check the rating label on the gas side burner for the most accurate information.



# EdgeStar Limited Warranty

This product is warranted by EdgeStar to be free from defective workmanship and materials, subject to any conditions set forth as follows:

## WHAT IS COVERED:

**LABOR:** For a period of NINETY (90) DAYS from the date of original purchase, labor will be performed free of charge at an authorized EdgeStar repair facility. At its option, EdgeStar will repair the product with new or remanufactured parts, or exchange the defective product with a new, refurbished, or remanufactured product. If a product is replaced, it will carry the remaining warranty of the original product. After the ninety (90) day period, EdgeStar will no longer be responsible for labor charges incurred. All defective products and parts covered by this warranty will be repaired or replaced on a mail-in basis to an EdgeStar authorized repair facility.

## PARTS:

- Ignition: One (1) year
- Lighting, electronics, & wiring: One (1) year
- Main burner(s): Three (3) years
- Valves: One (1) year
- Body, including hood, drip tray, firebox, griddle, and main body of the side burner: Three (3) years

For the periods of time specified above following the date of original purchase, EdgeStar will supply new, rebuilt, or refurbished parts free of charge. EdgeStar may request a defective part be returned in exchange for the replacement part. All replacement parts or products will be new, remanufactured, or refurbished. All products and parts replaced by EdgeStar under warranty service become the property of EdgeStar. Discoloration and surface corrosion do not qualify as defects.

This warranty applies to the original purchaser only, and only covers defects in workmanship experienced during operation of the product under normal service, maintenance, and usage conditions. This warranty applies to the purchase and use of this product in residential settings within the United States of America.

## WHAT IS NOT COVERED:

The following limitations apply to the coverage of this warranty. This warranty does not cover:

- Labor charges for installation, setup, or training to use the product.
- Shipping damage, and any damage caused by improper packaging for shipment to an authorized service center, and any damaged caused by improper voltage or any other misuse, including abnormal service, handling, or usage.
- Cosmetic damage such as scratches and dents.
- Normal wear and tear on parts or replacement of parts designed to be replaced, e.g. filters, cartridges, batteries.
- Service trips to deliver, pick-up, or repair, install the product, or to instruct in proper usage of the product.
- Damages or operating problems resulting from misuse, abuse, operation outside environmental specifications, uses contrary to instructions provided in the owner's manual, accidents, acts of God, vermin, fire, flood, improper installation, unauthorized service, maintenance negligence, unauthorized installation or modification, or commercial use.
- Labor charges incurred 91 days or more after the date of original purchase.
- The use of EdgeStar products in commercial settings.
- Optional accessories, attachments, and appearance items.
- Products that have been modified to perform outside of specifications without the prior written permission of EdgeStar.
- Products lost in shipment, or theft.
- Products sold AS IS or from an unauthorized reseller.
- Products that have had their serial numbers removed or defaced. Products with serial numbers that have been invalidated.

**OBTAINING WARRANTY SERVICE:**

If you believe your product is defective, contact EdgeStar Customer Support for troubleshooting assistance and warranty service at 1-866-319-5473. Please have your serial number and proof of purchase available. Once an EdgeStar authorized representative has confirmed that your product is defective and eligible for warranty service, the product must be returned to an EdgeStar repair facility. The purchaser is solely responsible for prepaying all shipping related costs to and from the repair facility. EdgeStar is not responsible for damage resulting from shipper mishandling or improper packaging. Do not return a defective product to the place of purchase. Products received without a return authorization number will be refused.

THIS WARRANTY IS IN LIEU OF ANY OTHER WARRANTY, EXPRESSED OR IMPLIED, INCLUDING WITHOUT LIMITATION, ANY WARRANTY OF MERCHANTABILITY OR FITNESS FOR A PARTICULAR PURPOSE. TO THE EXTENT ANY IMPLIED WARRANTY IS REQUIRED BY LAW, IT IS LIMITED IN DURATION TO THE EXPRESS WARRANTY PERIOD ABOVE. NEITHER THE MANUFACTURER NOR ITS DISTRIBUTORS SHALL BE LIABLE FOR ANY INCIDENTAL, CONSEQUENTIAL, INDIRECT, SPECIAL, OR PUNITIVE DAMAGES OF ANY NATURE, INCLUDING WITHOUT LIMITATION, LOST REVENUES OR PROFITS, OR ANY OTHER DAMAGE WHETHER BASED IN CONTRACT, TORT, OR OTHERWISE. SOME STATES DO NOT ALLOW THE EXCLUSION OF INCIDENTAL OR CONSEQUENTIAL DAMAGES, SO THE ABOVE EXCLUSION MAY NOT APPLY TO YOU. THIS WARRANTY GIVES YOU SPECIFIC LEGAL RIGHTS. YOU MAY HAVE OTHER RIGHTS THAT VARY FROM STATE TO STATE.