

SH12-A-LP/NG

SH12-A MANUAL

WHOLE-HOME TANKLESS WATER HEATERS
INSTALLATION, USE AND CARE INSTRUCTIONS

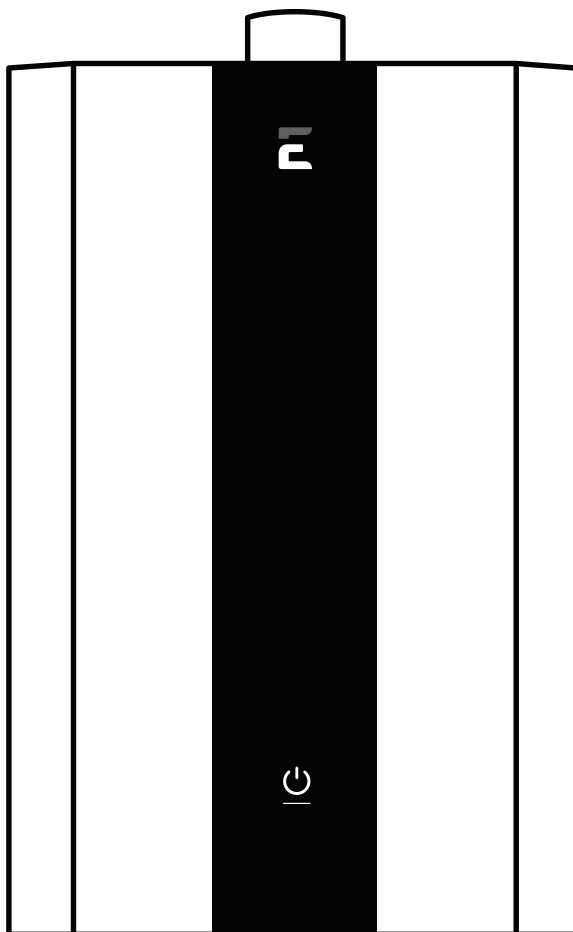

VOICE COMMANDS



REMOTE CONTROL



WIFI CONNECTED



SMART ON/OFF



SMART APP



SMARTHOME READY

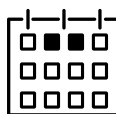

SCHEDULE & TIMER







ERROR DETECTION





WARNING! If the information in these instructions is not followed exactly, a fire or explosion may result causing property damage, personal injury or death.

- **Do not store or use gasoline or other flammable vapors and liquids in the vicinity of this or any other appliances.**
- **WHAT TO DO IF YOU SMELL GAS**
 - **Do not try to light any appliances.**
 - **Do not touch any electrical switch; do not use any phone in your building.**
 - **Immediately call your gas supplier from a neighbor's phone. Follow the gas supplier's instructions.**
 - **If you cannot reach your gas supplier, call the fire department.**
- **Installation and service must be performed by a qualified installer, service agency or the gas supplier.**



PLEASE NOTE: SH12-A IS FOR INDOOR PERMANENT INSTALLATIONS ONLY. THIS MANUAL AND ALL ECCOTEMP CONTENT IS SUBJECT TO CHANGE WITHOUT NOTICE. PLEASE VISIT SUPPORT.ECCOTEMP.COM FOR MORE INFORMATION.

 Eccotemp Systems, LLC 315-A Industrial Road Summerville, SC 29483 866-356-1992				  	
AUTOMATIC INSTANTANEOUS WATER HEATER					
MODEL #:	SH12-A-LP	Maximum Input Rating (Btu per hour):	80,000		
SERIAL #		Minimum Input Rating (Btu per hour):	25,000		
GAS TYPE:	LIQUID PROPANE ONLY	Minimum Inlet Gas Pressure:	9" w.c. (2.24 kPa)		
Voltage:	120 Volts	Maximum Inlet Gas Pressure:	12.9" w.c. (3.23 kPa)		
Frequency:	60 Hz	Manifold Pressure:	4.93" w.c. (1.22 kPa)		
Amps:	Less than 10 Amps	Maximum Working Pressure:	150 PSI		
Recovery Rating:	As used in this standard, the quantity of water obtained by multiplying the manufacturer's input rating in Btu per hour by the thermal efficiency and dividing the product by 8.25 Btu per gallon. This is based on a 100°F (37.8°C) temperature rise, and a nominal specific heat for water of 8.25 Btu per gallon per degree F.				
Not recommended in excess of 2,000 ft. above sea level.			Category III Water Heater		
CSA/ANSI Z21.10.3 - CSA 4.3-2019		SUITABLE FOR WATER (POTABLE) HEATING ONLY			
FOR YOUR SAFETY Do not store or use gasoline or other flammable vapors and liquids in the vicinity of this or any other appliance.		This appliance must be installed in accordance with local codes or, in the absence of local codes, the National Fuel Gas Code, ANSI Z223.1/NFPA 54, and CSA B149.1, Natural Gas and Propane Installation Code			
The unit must be installed on a fire retardant area, and must be away from all combustible materials. Minimum clearances from combustible construction, 6 inches sides, 0 inches back and 12 inches top.					
The temperature and pressure relief valve provided by the manufacturer shall be installed at the time of installation of the heater in the location specified by the manufacturer. Local codes shall govern installation of relief devices. For safe operation of the water heater, the relief valve must not be removed or plugged.					
This water heater requires a special venting system. Refer to the installation instructions for parts list and method of installation.					
INDOOR USE ONLY					

 Eccotemp Systems, LLC 315-A Industrial Road Summerville, SC 29483 866-356-1992				  	
AUTOMATIC INSTANTANEOUS WATER HEATER					
MODEL #:	SH12-A-NG	Maximum Input Rating (Btu per hour):	140,000		
SERIAL #		Minimum Input Rating (Btu per hour):	25,000		
GAS TYPE:	NATURAL GAS ONLY	Minimum Inlet Gas Pressure:	4" w.c. (1 kPa)		
Voltage:	120 Volts	Maximum Inlet Gas Pressure:	10.5" w.c. (3.23 kPa)		
Frequency:	60 Hz	Manifold Pressure:	3.05" w.c. (0.76 kPa)		
Amps:	Less than 10 Amps	Maximum Working Pressure:	150 PSI		
Recovery Rating:	As used in this standard, the quantity of water obtained by multiplying the manufacturer's input rating in Btu per hour by the thermal efficiency and dividing the product by 8.25 Btu per gallon. This is based on a 100°F (37.8°C) temperature rise, and a nominal specific heat for water of 8.25 Btu per gallon per degree F.				
Not recommended in excess of 2,000 ft. above sea level.			Category III Water Heater		
CSA/ANSI Z21.10.3 - CSA 4.3-2019		SUITABLE FOR WATER (POTABLE) HEATING ONLY			
FOR YOUR SAFETY Do not store or use gasoline or other flammable vapors and liquids in the vicinity of this or any other appliance.		This appliance must be installed in accordance with local codes or, in the absence of local codes, the National Fuel Gas Code, ANSI Z223.1/NFPA 54, and CSA B149.1, Natural Gas and Propane Installation Code			
The unit must be installed on a fire retardant area, and must be away from all combustible materials. Minimum clearances from combustible construction, 6 inches sides, 0 inches back and 12 inches top.					
The temperature and pressure relief valve provided by the manufacturer shall be installed at the time of installation of the heater in the location specified by the manufacturer. Local codes shall govern installation of relief devices. For safe operation of the water heater, the relief valve must not be removed or plugged.					
This water heater requires a special venting system. Refer to the installation instructions for parts list and method of installation.					
INDOOR USE ONLY					

PLEASE NOTE: SH12-A IS FOR INDOOR PERMANENT INSTALLATIONS ONLY. THIS MANUAL AND ALL ECCOTEMP CONTENT IS SUBJECT TO CHANGE WITHOUT NOTICE. PLEASE VISIT SUPPORT.ECCOTEMP.COM FOR MORE INFORMATION.



PLEASE VERIFY THIS WATER HEATER IS RIGHT FOR YOU

Congratulations on your purchase of an Eccotemp Gas Tankless Water Heater!
 THINGS YOU SHOULD KNOW ABOUT THIS WATER HEATER:

RECOMMENDED USES	HOUSEHOLD SIZE	TEMPERATURE CONTROLS
<ul style="list-style-type: none"> Whole Home, Residential Commercial All Zones (See map below) 	 OR 1-2 APPLICATIONS	APPLICATIONS TEMPERATURE CONTROLS The temperature can be set with the included remote control or by using the Eccotemp SMARTHOME app and automatically adjusted at your sink or shower.



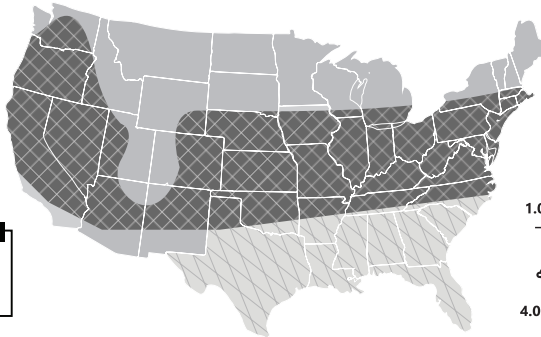
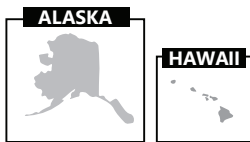

INCOMING WATER TEMPERATURE

ZONE 1	67 - 77° F
ZONE 2	52 - 62° F
ZONE 3	37 - 47° F
*ZONE 4	35 - 45

(*Alaska - only shown)



STANDARD APPLICATION FLOWS

	
1.0-2.0 GPM	1.5-2.0 GPM
	
4.0 - 5.0 GPM	1.0 - 1.5 GPM

MODEL	FLOW U/M	TEMPERATURE RISE (IN DEGREES)										
		80	75	70	65	60	55	50	45	40	35	30
SH12-A	gpm	0.7	1.0	1.4	1.7	2.1	2.4	2.8	3.1	3.4	3.8	4.1
SHLX	gpm	0.9	1.3	1.8	2.2	2.7	3.1	3.6	4.0	4.4	4.9	5.3
6GB	gpm	1.1	1.7	2.3	2.8	3.4	4.0	4.5	5.1	5.7	6.2	6.8
SH22	gpm	1.3	1.9	2.6	3.2	3.9	4.5	5.2	5.8	6.4	7.1	7.7
SH22-I	gpm	1.3	1.9	2.6	3.2	3.9	4.5	5.2	5.8	6.4	7.1	7.7
45H	gpm	1.3	1.9	2.6	3.2	3.9	4.5	5.2	5.8	6.4	7.1	7.7
45HI	gpm	1.3	1.9	2.6	3.2	3.9	4.5	5.2	5.8	6.4	7.1	7.7
6.8GB	gpm	1.3	1.9	2.6	3.2	3.9	4.5	5.2	5.8	6.4	7.1	7.7
6.8GB-I	gpm	1.3	1.9	2.6	3.2	3.9	4.5	5.2	5.8	6.4	7.1	7.7
7GB	gpm	1.8	2.6	3.6	4.4	5.4	6.2	7.2	8.0	8.8	9.8	10.6

Improper installation, adjustment, alteration, service or maintenance can cause property damage, personal injury, or death. Installation and service must be performed by a qualified installer or service technician.

PLEASE NOTE: SH12-A IS FOR INDOOR PERMANENT INSTALLATIONS ONLY. THIS MANUAL AND ALL ECCOTEMP CONTENT IS SUBJECT TO CHANGE WITHOUT NOTICE. PLEASE VISIT SUPPORT.ECCOTEMP.COM FOR MORE INFORMATION.

Use & Care Manual

With Installation Instructions for the Installer

APPLICATION Residential	INSTALLATION Indoor	BTU'S 80,000	SH12-A-LP 4.0 GPM	SH12-A-NG 4.0 GPM
-----------------------------------	-------------------------------	------------------------	-----------------------------	-----------------------------

SMARTHOME Tankless Water Heater

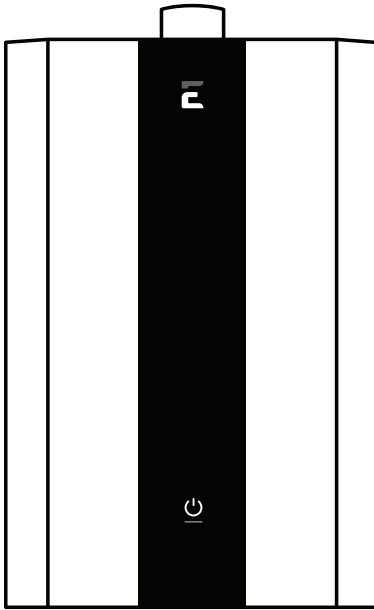

⚠ WARNING! This water heater may not be suitable for use in manufactured (mobile) homes! Please check local code restrictions pertaining to permanent/fixed installations in manufactured homes in your area.

The purpose of this manual is twofold: one, to provide the installer with the basic directions and requirements for the proper installation and adjustment of the water heater; and two, to the owner-operator, to explain the features, operation, safety precautions, maintenance and troubleshooting of the water heater. This manual also includes a parts list.

It is imperative that all persons who are expected to install, operate or adjust this water heater read the instructions carefully so they may understand how to perform these operations. If you don't understand these instructions or any terms within it, seek professional advice.

Any questions regarding the operation, maintenance, service or warranty of this water heater should be directed to the seller from whom it was purchased. If additional information is required, refer to the section on If You Need Service.

Do not destroy this manual. Please read carefully and keep in a safe place for future reference.

⚠ Recognize this symbol as an indication of Important Safety Information!

⚠ WARNING: California Proposition 65 Warning: This product contains chemicals known to the State of California to cause cancer, birth defects or other reproductive harm.

⚠ WARNING: If the information in these instructions is not followed exactly, a fire or explosion may result causing property damage, personal injury or death.

⚠ FOR YOUR SAFETY!

Improper installation, adjustment, alteration, service or maintenance can cause property damage, personal injury, or death. Refer to this manual. Installation and service must be performed by a qualified installer, service agency or the gas supplier.

DO NOT store or use gasoline or other flammable vapors or liquids or other combustible materials in the vicinity of this or any other appliance. To do so may result in an explosion or fire.

WHAT TO DO IF YOU SMELL GAS

- **DO NOT** try to light any appliances.
- **DO NOT** touch any electrical switch; do not use any phone in your building.
- **IMMEDIATELY** call your gas supplier from a neighbor's phone. Follow the gas supplier's instructions.
- If you cannot reach your gas supplier, call the fire department.
- **DO NOT** return to your home until authorized by the gas supplier or fire department.

PLEASE NOTE: SH12-A IS FOR INDOOR PERMANENT INSTALLATIONS ONLY. THIS MANUAL AND ALL ECCOTEMP CONTENT IS SUBJECT TO CHANGE WITHOUT NOTICE. PLEASE VISIT SUPPORT.ECCOTEMP.COM FOR MORE INFORMATION.

SAFETY INFORMATION

Safety Information

Safety Precautions 1-10

SH12-A Installation Instructions

Typical Installation 11-12
 Location 13-14
 Water Connections 16-17
 Gas Supply 17
 Relief Valve 18
 Leak Testing 18
 Venting 19-26
 Electrical Connection 27
 Pipe Insulation 28
 Mounting 29
 Installation Checklist 30

Operation Instructions

Start Instructions 31
 Lighting the Heater 31
 Water Temperature 32
 Remote Control 34
 Smart App 35-37

Maintenance

Housekeeping 38-39
 Extended Shut-Down 39
 Anti-Freezing 39
 Draining 40
 Parts 41

Troubleshooting

Before You Call For Service 42
 Error Code Guide 43

Customer Service

Warranty Info 44-45
 Notes 46-47

FOR YOUR RECORDS

Write your serial numbers here:

 # _____

You can find them on a label on the appliance and/or packaging.

Staple sales slip or canceled check here.

Proof of the original purchase date is needed to obtain service under the warranty.

READ THIS MANUAL

Inside you will find many useful tips on how to use and maintain your water heater correctly. A little preventative care on your part can save you time and money over the life of your water heater. You'll find many answers to common problems in the Troubleshooting Guide. If you check the Troubleshooting Tips table first, you may not need to call for service.

READ THE SAFETY INFORMATION

Your safety and the safety of others are very important. There are many important safety messages in this manual and on your water heater. Always read and obey all safety messages.

⚠ This is the safety alert symbol. Recognize this symbol as an indication of Important Safety Information! This symbol alerts you to potential hazards that can kill or hurt you and others.

All safety messages will follow the safety alert symbol and the words: **"DANGER", "WARNING", "CAUTION" or "NOTICE"**.

These words mean:

⚠ DANGER! An imminently hazardous situation that will result in death or serious injury.

⚠ WARNING! A potentially hazardous situation that could result in death or serious injury and/or damage to property.

⚠ CAUTION! A potentially hazardous situation that may result in minor or moderate injury.

⚠ NOTICE! Attention is called to observe a specified procedure or maintain a specific condition.

PLEASE NOTE: SH12-A IS FOR INDOOR PERMANENT INSTALLATIONS ONLY. THIS MANUAL AND ALL ECCOTEMP CONTENT IS SUBJECT TO CHANGE WITHOUT NOTICE. PLEASE VISIT SUPPORT.ECCOTEMP.COM FOR MORE INFORMATION.

IMPORTANT SAFETY INFORMATION: READ ALL INSTRUCTIONS BEFORE USE

Be sure to read and understand the entire Use and Care Manual before attempting to install or operate this water heater. It may save you time and money. Pay particular attention to the Safety Instructions. Failure to follow these warnings could result in serious bodily injury or death. Should you have problems understanding the instructions in this manual, or have any questions, **STOP**, and get help from a qualified service technician, or the local gas utility.

! DANGER!

Failure to properly install the water heater outdoors as outlined in the Installation Instructions in this manual can result in unsafe operation of the water heater. To avoid the risk of fire, explosion, or asphyxiation from carbon monoxide, never operate this water heater unless it is installed properly and has an adequate air supply for proper operation. Be sure to inspect the flue terminal for proper installation at initial start-up; and at least annually thereafter. Refer to the Care and Cleaning section of this manual for more information regarding flue terminal inspection.

! WARNING!

Gasoline, as well as other flammable materials and liquids (adhesives, solvents, paint thinners etc.), and the vapors they produce are extremely dangerous. **DO NOT** handle, use or store gasoline or other flammable or combustible materials anywhere near or in the vicinity of a water heater or any other appliance. Be sure to read and follow the labels on the water heater, as well as the warnings printed in this manual. Failure to do so can result in property damage, bodily injury or death.

DANGER



Flammable Vapor

<p>! Vapors from flammable liquids will explode and catch fire causing death or severe burns.</p>	
<p>DO NOT use or store flammable products such as gasoline, solvents or adhesive in the same room or area near the water heater.</p> <p>Keep flammable products:</p> <ol style="list-style-type: none"> 1. Far away from heater 2. In approved cont 3. Tightly closed 4. Out of children's reach 	<p>Water heater has a main burner flame.</p> <p>The main burner flame:</p> <ol style="list-style-type: none"> 1. Can come on at any time and 2. will ignite flammable vapors. <p>Vapors:</p> <ol style="list-style-type: none"> 1. Cannot be seen 2. Are heavier than air 3. Go a long way on the floor 4. Can be carried from other rooms to the main burner flame by air currents.
<p>Installation: Do not install water heater where flammable products will be stored or used unless the main burner flame is at least 18" above the floor. This will reduce, but not eliminate, the risk of vapors being ignited by the main burner flame.</p>	
<p>Read and follow water heater warnings and instructions. If owners manual is missing, contact the retailer or manufacturer.</p>	

PLEASE NOTE: SH12-A IS FOR INDOOR PERMANENT INSTALLATIONS ONLY. THIS MANUAL AND ALL ECCOTEMP CONTENT IS SUBJECT TO CHANGE WITHOUT NOTICE. PLEASE VISIT SUPPORT.ECCOTEMP.COM FOR MORE INFORMATION.

IMPORTANT SAFETY INFORMATION: READ ALL INSTRUCTIONS BEFORE USE

⚠ DANGER!

WATER TEMPERATURE SETTING

Safety and energy conservation are factors to be considered when selecting the water temperature setting. Water temperatures above 125°F can cause severe burns or death from scalding. The thermostat is adjusted to its lowest temperature position when shipped from the factory. Be sure to read and follow the warnings outlined on the label pictured below.



Water temperature over 125°F (51°C) can cause severe burns instantly or death scalds.

Children, disabled, and elderly are at highest risk of being scalded.

See instruction manual before setting temperature at water heater. Feel water before using. Temperature limiting valves are available.

Turn water heater ON/OFF

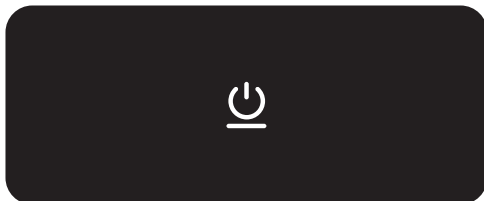

Hold the button down for 5 seconds to get into EZ connection mode (fast blink) and hold down for another 5 seconds to get into AP connection mode (slow blink) that produces a Wi-Fi hotspot to connect to.

Time / Temperature Relationship in Scales	
Water Temperature	Time to Product a serious Burn
120	More than 5 minutes
125	1 1/2 to 2 minutes
130	About 30 seconds
135	About 10 seconds
140	Less than 5 seconds
145	Less than 3 seconds
150	About 1 1/2 seconds
155	About 1 second
Table courtesy of Shriners Burn Institute	

The chart shown above may be used as a guide in determining the proper water temperature for your home.

⚠ DANGER! Households with small children, disabled, or elderly persons may require a 120°F or lower temperature setting to prevent contact with "HOT" water.

Maximum water temperature occurs while burner is on. To find water temperature being delivered, turn on a hot water faucet and place a thermometer in the water stream and read the thermometer.

The temperature of the water at the outlet of the water heater can be regulated by setting the temperature on the Remote Control. The remote control may have been set at 110°F before it was shipped from the factory.

⚠ NOTICE: When this water heater is supplying general purpose hot water requirements for use by individuals, a thermostatically controlled mixing valve for reducing point of use water temperature is recommended to reduce the risk of scald injury. Contact a licensed plumber or the local plumbing authority for further information.

⚠ NOTICE: The factory recommended operating temperatures are between 90°F and 140°F.

⚠ NOTICE! This is an automatic temperature controlled tankless water heater. This means that the temperature must be set from the Eccotemp app or remote control. You can restrict the flow of the incoming water using the built in flow restrictor in order to achieve a desired set temperature. This tankless water heater is flow activated and will adjust gas flames to heat water as necessary.

PLEASE NOTE: SH12-A IS FOR INDOOR PERMANENT INSTALLATIONS ONLY. THIS MANUAL AND ALL ECCOTEMP CONTENT IS SUBJECT TO CHANGE WITHOUT NOTICE. PLEASE VISIT SUPPORT.ECCOTEMP.COM FOR MORE INFORMATION.

IMPORTANT SAFETY INFORMATION: READ ALL INSTRUCTIONS BEFORE USE

WARNING!

For your safety, the information in this manual must be followed to minimize the risk of fire explosion, electric shock, or to prevent property damage, personal injury, or loss of life.

FOR INSTALLATIONS IN THE STATE OF CALIFORNIA

California Law requires that residential water heaters must be braced, anchored or strapped to resist falling or horizontal displacement due to earthquake motions. For residential water heaters up to 52 gallon capacity, a brochure with generic earthquake bracing instructions can be obtained from: Office of the State Architect, 400 P Street, Sacramento, CA 95814 or you may call 916-445-8100 or ask a water heater dealer.

However, applicable local codes shall govern installation. For residential water heaters of a capacity greater than 52 gallons or tankless style, consult the local building code for acceptable bracing procedures.

SAFETY PRECAUTIONS

Have the installer show you the location of the gas shut-off valve and how to shut it off if necessary. Turn off the manual shut-off valve if the water heater has been subjected to overheating, fire, flood, physical damage or if the gas supply fails to shut-off.

- Read this manual entirely before installing or operating the water heater.
- Use this water heater only for its intended purpose as described in this Use and Care Manual.
- Be sure your water heater is properly installed in accordance with federal, state, and local codes and the provided installation instructions.
- All installations and servicing should be referred to a qualified technician.

READ AND FOLLOW THIS SAFETY INFORMATION CAREFULLY SAVE THESE INSTRUCTIONS

This water heater must be installed in accordance with these local codes, utility company requirements, and/or in the absence of local codes, use the latest edition of the American National Standard/National Fuel Gas Code. A copy can be purchased from either the American Gas Association, 400 North Capitol Street NW, Washington, DC 20001 as ANSI standard z223.1 or National Fire Protection Association, 1 Batterymarch Park, Quincy, MA 02269 as NFPA 54. In Canada, the latest edition of the CSA B149.1 Natural Gas and Propane Installation, and the Canadian Electrical Code, CSA C22.1 Part 1, in the absence of local codes.

PLEASE NOTE: SH12-A IS FOR INDOOR PERMANENT INSTALLATIONS ONLY. THIS MANUAL AND ALL ECCOTEMP CONTENT IS SUBJECT TO CHANGE WITHOUT NOTICE. PLEASE VISIT SUPPORT.ECCOTEMP.COM FOR MORE INFORMATION.

IMPORTANT SAFETY INFORMATION: READ ALL INSTRUCTIONS BEFORE USE

DANGER!

NATURAL GAS AND LIQUEFIED PETROLEUM MODELS

Both liquid propane gas (LPG) and natural gas (NG) have an odorant added to aid in detecting a gas leak. Some people may not physically be able to smell or recognize this odorant. If you are unsure or unfamiliar with the smell of LPG or NG, ask the gas supplier. Other conditions, such as "odorant fade", which causes the odorant to diminish in intensity, can also hide or camouflage a gas leak. Always check with commercial leak detector or soapy water.

- Gas detectors are recommended in LPG and NG applications and their installation should be in accordance with the detector manufacturer's recommendations and/or local laws, rules, regulations or customs.
- Water heaters utilizing LPG are different from NG models. A NG water heater will not function safely on LPG and vice versa.
- No attempt should ever be made to convert the water heater from NG to LPG. To avoid possible equipment damage, personal injury or fire, do not connect the water heater to a fuel type not in accordance with the water heater data plate; liquid propane gas for LPG water heaters and natural gas for NG water heaters. These water heaters are not certified for any other fuel type.
- LPG water heaters should not be installed below grade (for example, in a basement) if such installation is prohibited by federal, state and/or local laws, rules, regulations or customs.
- LPG must be used with great caution. It is heavier than air and will collect first in lower areas making it hard to detect at nose level.
- Before attempting to light the water heater, make sure to look and smell for gas leaks. Use a soapy solution to check all gas fittings and connections. Bubbling at a connection indicates a leak that must be corrected. When smelling to detect a gas leak, be sure to sniff near the floor also.
- It is recommended that more than one method, such as soapy solution, gas detectors, etc., be used to detect leaks in gas applications.

NOTICE: If a gas leak is present or suspected:

- **DO NOT attempt to find the cause yourself.**
- **DO NOT try to light any appliances.**
- **DO NOT touch any electrical switches.**
- **DO NOT use any phones in your building.**
- **Leave the house immediately and make sure your family and pets leave also.**
- **Leave the doors open for ventilation and contact the gas supplier, a qualified service agency or the fire department.**
- **Stay away from the house (or building) until the service call has been made, the leak is corrected and qualified agency has determined the area to be safe.**

INSTALLING THE SH12-A

Typical Installation (Some Items May Not Apply)

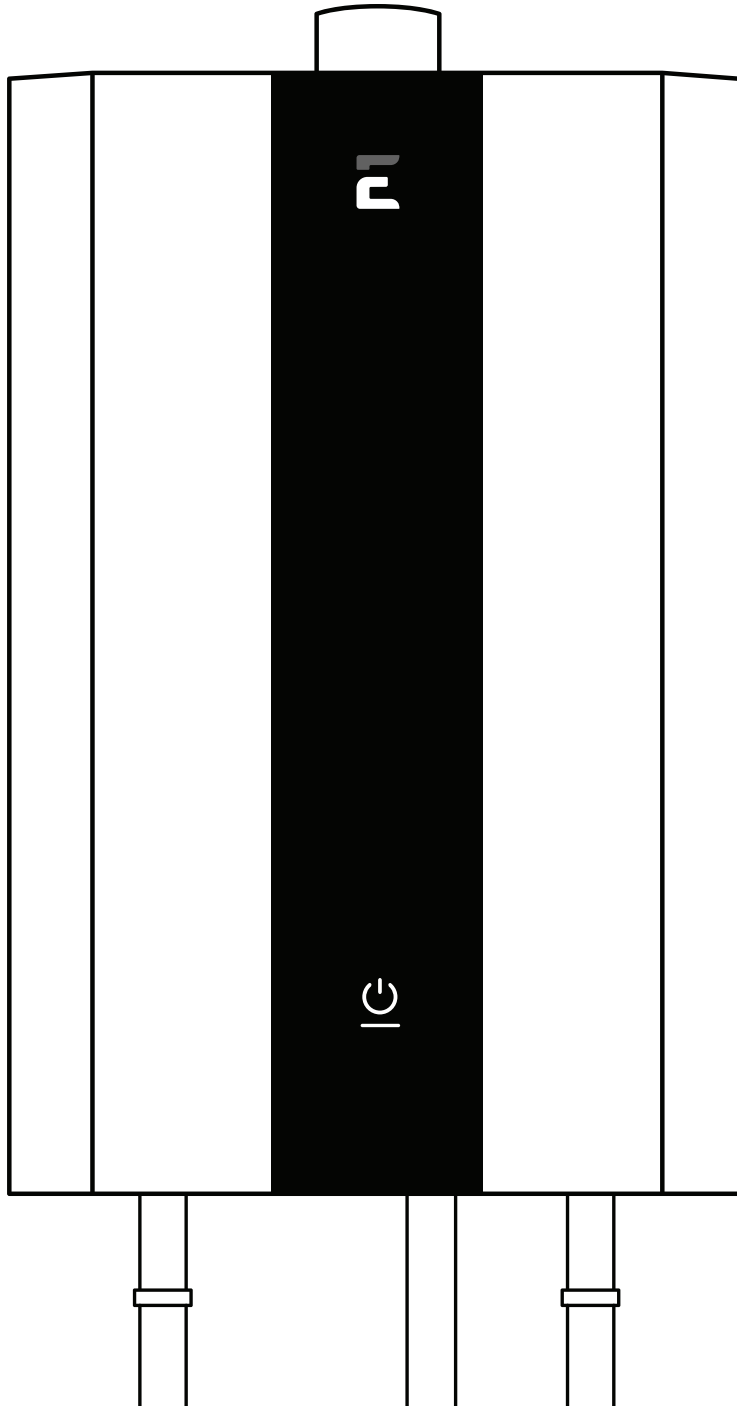

PLEASE NOTE: SH12-A IS FOR INDOOR PERMANENT INSTALLATIONS ONLY. THIS MANUAL AND ALL ECCOTEMP CONTENT IS SUBJECT TO CHANGE WITHOUT NOTICE. PLEASE VISIT SUPPORT.ECCOTEMP.COM FOR MORE INFORMATION.

INSTALLING THE SH12-A

Typical Installation (Some Items May Not Apply)

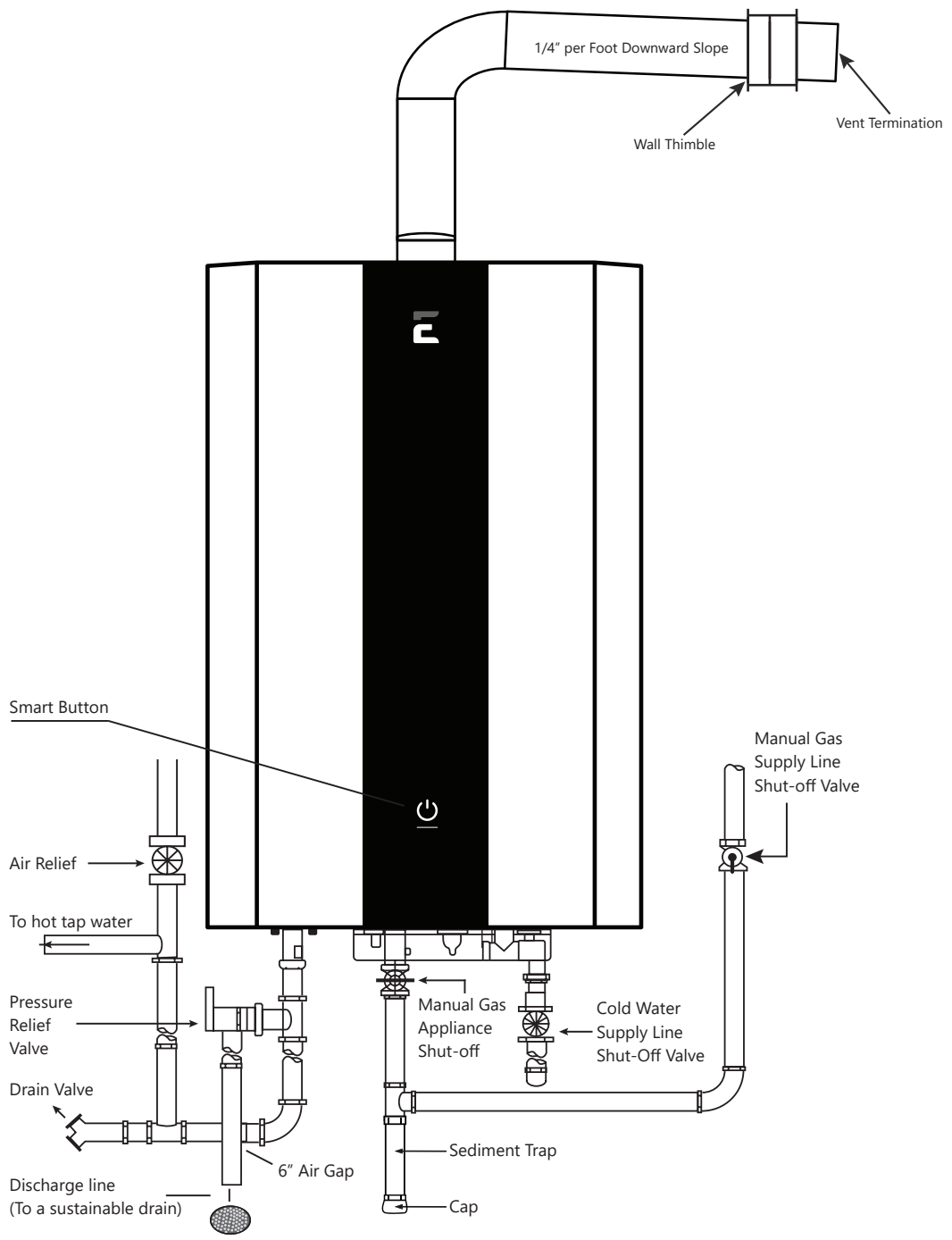

⚠ NOTICE: The National Fuel Gas Code (NFGC) mandates a manual gas shut-off valve: See (NFGC) for complete instructions. Local codes or plumbing authority requirements may vary from the instructions or diagrams provided and take precedent over these instructions.

PLEASE NOTE: SH12-A IS FOR INDOOR PERMANENT INSTALLATIONS ONLY. THIS MANUAL AND ALL ECCOTEMP CONTENT IS SUBJECT TO CHANGE WITHOUT NOTICE. PLEASE VISIT SUPPORT.ECCOTEMP.COM FOR MORE INFORMATION.

INSTALLING THE SH12-A

LOCATION

- Installation distances may vary by local code. It is the installer's responsibility to verify installation requirements.
- Make sure before installation that the gas type you will use is the same type on the data plate.
- The water heater should be installed by professionals. Improper installation may cause failure or dangerous conditions such as gas leaking or explosion.
- Failure to have the water heater installed by a professional will void your warranty.
- Water heater cannot be installed in an UN-VENTED bathroom, bedroom, basement, living room, closet, outdoor, stairway or an exit area. If installed in an exit area, it must be at least 16.5 ft. or more away from the exit.
- Vent pipe should extend from the wall at least 2". The terminal must be at least 1.64 ft. away from obstruction and must be well vented.
- Ensure a backflow preventer has been installed to the vent piping.
- Install a condensation trap and drain (as required).
- Vent pipe should slope 3° downward, to avoid condensing water and protect from rain entering.
- Vent pipe should avoid direct, strong wind because the downdraft will cause malfunction.
- The water heater should be installed far from any blockage, and with plenty of enough space for installation and maintenance. Adequate clearances for servicing must be provided.
- The water heater should not be installed in the same room with a gas stove.
- When determining the floor clearance, a clearance of 12 inches must be maintained between the vent pipe and combustible material. A side wall clearance of 10 inches and a top clearance of 16 inches must be maintained.
- The vent pipe can be up to 32ft in length with one elbow.
- The vent pipe should be installed with a flame retardant wall thimble. Owner must refer to vent manufacturer's instructions and specifications. Eccotemp information can be found at www.eccotemp.com, please refer to page 31 for additional links. Installation guidelines for venting provided by NovaFlex, who is solely responsible for venting installation accuracy.
- The power socket connecting the water heater should be grounded properly with a GFCI circuit protector.
- The water heater should not be located in an area where leakage of the heat exchanger or connections will result in damage to the area adjacent to it or to lower floors of the structure. When such areas cannot be avoided it is recommended that a suitable catch pan, adequately drained, must be installed under the water heater. The pan must not restrict combustion airflow.
- This water heater **MUST NOT** be installed in a laundry room or in the same room as the washer dryer. Installation of the water heater in a laundry room or in the vicinity of a washer/dryer will void the warranty.
- The water heater should be installed as close as practical to the vent termination to minimize vent length and the number of elbows required for venting.

PLEASE NOTE: SH12-A IS FOR INDOOR PERMANENT INSTALLATIONS ONLY. THIS MANUAL AND ALL ECCOTEMP CONTENT IS SUBJECT TO CHANGE WITHOUT NOTICE. PLEASE VISIT SUPPORT.ECCOTEMP.COM FOR MORE INFORMATION.

INSTALLING THE SH12-A

- Proper operation of the water heater requires air for combustion and ventilation. Provisions for combustion and ventilation air must comply with referenced codes and standards.
- A gas fired water heater, or any other appliances should not be installed in a space where liquids which give off flammable vapors are to be used or stored. Such liquids include gasoline, LPG (butane or propane), paint or adhesives and their thinners, solvents or removers.
- The water heater should be installed far from heat sources, flammable and dangerous materials. Because of natural air movement in a room or other enclosed space, flammable vapors can be carried some distance from where their liquids are being used or stored. The open flame of the water heater's main burner can ignite these vapors causing an explosion or fire which may result in severe burns, death or property damage.
- Raising the water heater will reduce BUT NOT eliminate the possibility of lighting the vapor of any flammable liquids which may be improperly stored or accidentally spilled.
- If the water heater is installed in a garage, it should be installed so that the direct ignition system and main burner are no less than 18" above the garage floor.
- Hot and cold water lines should be insulated to conserve water and energy.
- The water heater must be located so it is not subject to physical damage, for example, by moving vehicles, area flooding, etc.
- The water heater should be installed with the proper venting materials and termination suitable for Category III venting. Failure to install and properly vent the water heater to the outdoors as outlined in the Venting Section of this manual can result in unsafe operation. Owner must refer to vent manufacturer's instructions and specifications. Eccotemp information can be found at www.eccotemp.com. Please refer to page 34 for additional links.
- For other than a direct vent appliance, the appliance must be located as close as possible to a chimney or gas vent.
- **DO NOT** install the water heater near vents for heating or cooling. A minimum of 4 feet should be maintained.
- If your clearances differ from the stated clearances on the instruction warning label, located on the front panel of the heater, install the water heater according to the clearances stated on the label.

⚠ Combustible construction refers to adjacent walls and ceilings and should not be confused with combustible or flammable products and materials. Combustible and/or flammable products and materials should never be stored near this product or any other gas appliance.

The vent on this appliance must not terminate:

1. On public passages; Or
2. Near soffit vents or crawl space vents or other areas where condensation or steam could create a nuisance or hazard or cause property damage; Or
3. Where condensate steam could cause damage or impair the operation of regulators, relief valves or other equipment.

INSTALLING THE SH12-A

COMBUSTION AND VENTILATION AIR

Proper operation of the water heater requires air for combustion and ventilation. Provisions for combustion and ventilation air must comply with referenced codes and standards.

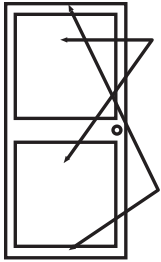

Air Openings
Min. 200 Sq. In.

Min. 4"

A confined space is one having a volume of less than 50 cubic feet per 1,000 BTUH of the aggregate input of all appliances within that space.

The air must be supplied through two permanent openings of equal area. One is to be located within 12" above the floor and the other is to be located within 12" below the ceiling.

The minimum net free area of each opening must not be less than one square inch per 1,000 BTUH of the total input rating of all the appliances in the enclosure (but not less than 100 square inches), if each opening communicates with other unconfined areas inside the building.

Buildings of unusually tight construction shall have the combustion and ventilation air supplied from outdoors, or a freely ventilated attic or crawl space. If air is supplied from outdoors, directly or through vertical ducts, there must be two openings located as specified above and each must have a minimum net free area of not less than one square inch per 4,000 BTUH of the total input rating of all the appliances in the enclosure.

If horizontal ducts are used to communicate with the outdoors, each opening must have a minimum net free area of not less than one square inch per 2,000 BTUH of the total input rating of all the appliances in the enclosure. If ducts are used, the minimum dimensions of rectangular air ducts shall not be less than 4".

⚠ NOTICE: If the water heater is installed in an unconfined space within a building of conventional frame, masonry or metal construction, infiltration air is normally adequate for proper combustion and ventilation. If the water heater is installed in a confined space, provisions for combustion and ventilation air must be made.

⚠ NOTICE: If the duct openings which supply combustion and ventilation air are to be covered with a protective screen or grill, the net free area (openings in the material) of the covering material must be used in determining the size of the openings. Protective screening for the openings MUST NOT be smaller than 1/4" to prevent clogging by lint or other debris.

CORROSIVE ATMOSPHERES

The air in beauty shops, dry cleaning establishments, photo processing labs, and storage areas for liquid and powdered bleaches or swimming pool chemicals often contain such halogenated hydrocarbons.

An air supply containing halogenated hydrocarbons may be safe to breathe, but when it passes through a gas flame corrosive elements are released that will shorten the life of any gas burning appliance.

Propellants from common spray cans or gas leaks from A/C and refrigeration equipment are highly corrosive after passing through a flame.

The water heater warranty is voided when failure of the heater is due to operation in a corrosive atmosphere.

⚠ NOTICE: The water heater should not be installed near an any air supply containing halogenated hydrocarbons.

INSPECT SHIPMENT

Inspect the water heater for possible damage. Check the markings on the rating plate of the water heater to be certain the type of gas supplied corresponds to the water heater requirements. Verify all included parts are present (see below).

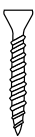

Wood Screw
x 2 pcs.



Remote Control
x 1 pcs.



Washer
x 2 pcs.



3/4" Pressure Relief
Valve 1 pcs. (Included in
Canada Shipments Only)



Expansion Screw
x 2 pcs.



Use and Care
Manual

PLEASE NOTE: SH12-A IS FOR INDOOR PERMANENT INSTALLATIONS ONLY. THIS MANUAL AND ALL ECCOTEMP CONTENT IS SUBJECT TO CHANGE WITHOUT NOTICE. PLEASE VISIT SUPPORT.ECCOTEMP.COM FOR MORE INFORMATION.

INSTALLING THE SH12-A

WATER SUPPLY CONNECTION

Plumbing should be carried out by a qualified plumber in accordance with local codes. Use approved plumbing materials and tools only. Install a check valve between the water heater and the water shutoff valve. (See illustration below).

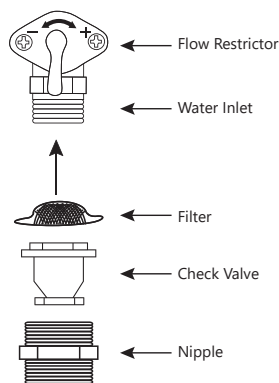

To conserve energy and to prevent freezing, insulate both cold and hot water supply lines. **DO NOT** cover the drain valves. Install a shutoff valve near the inlet of the water heater for service and draining purposes. Before connecting the water supply pipe to the water heater, open the shutoff valve and clean out sand, debris, air, caulking material, etc. inside the pipe. Connect to the water inlet, then check water flow. Close the shutoff valve and clean the water filter.

If a water heater is installed in a closed water supply system, such as one having a backflow preventer in the cold water supply line, means shall be provided to control thermal expansion. Contact the water supplier or local plumbing inspector on how to control this situation.

⚠ CAUTION! This water heater must only be used with the following water supply system conditions:

- With clean, potable water free of corrosive chemicals, sand, dirt, or other contaminants.
- With inlet water temperatures above 32°F, but not to exceed 120°F.
- Free of lime and scale deposits.
- DO NOT reverse the hot and cold water connections. The water heater will not operate.

To ensure proper operation of the water heater, the following water pressure guidelines should be followed:

- Operation of the SH12-A **SMARTHOME** Gas Tankless Water Heater requires a minimum water flow rate of 0.7 GP to activate and 0.6 GPM to maintain activation.
- Additional water pressure is required for long pipe runs and outlet fitting(s) water pressure drops.
- To maintain proper performance, ensure sufficient water supply pressure. The Required Water Flow Rate = Min. Operating Water Pressure (0.6 GPM) + Pipe Pressure Loss + Faucet and Shower Pressure Loss + Safety Margin (more than 5 psi).
- To supply hot water to upper floors, additional water pressure (0.44 psi/ft) must be ensured. The measurement should be calculated by the distance between the water inlet of the water heater (ground level) to the hot water faucet (upper floor level).
- Well water systems should be set at a range of 50-60 psi.
- When the water is supplied from a water supply tank, the height of the tank and the diameter of the pipes and their relation to water pressure, should be taken into consideration. Gravity water pressure is not recommended.

⚠ IMPORTANT! Do not apply heat to the HOT or COLD water connections. Any heat applied to the water supply fittings will permanently damage the internal components of the water heater.

⚠ NOTICE! If the water pressure resistance of a shower head is too high, the burner in the water heater will fail to ignite. Keep the shower head clean from debris that could cause additional pressure drop.

⚠ NOTICE! If using mixing valves on the outlet, choose one which prevents cold water pressure from overcoming hot water line pressure.

DO NOT use pipes with smaller diameters than the water supply connection of the water heater.

Be sure to connect the water inlet and the hot water outlet as shown on the water heater. If reversed, the water heater will not function.

Installation of unions or flexible copper connections are recommended on the **HOT** and **COLD** water lines, so that the water heater may disconnect easily for servicing if necessary.

INSTALLING THE SH12-A

WATER CONNECTION CONT.

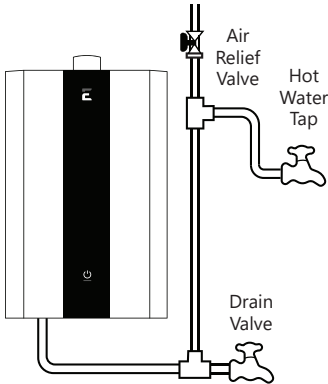

In regards to the HOT WATER OUTLET:

- Connections between the water heater and point(s) of use should be as short and direct as possible.
- **DO NOT** use lead or non-approved plastic pipe.
- To conserve energy and minimize heat loss, insulation of hot water piping is recommended.

⚠ NOTICE! The flow rate of hot water may vary when more than two faucets (appliances, fixtures, etc.) are being used simultaneously.

⚠ NOTICE! The pipes **MUST** be completely drainable. If hot water faucets are located at a point higher than the water heater, place a drain valve at the lowest point (see diagram to the left).

GAS SUPPLY

⚠ WARNING! Do not attempt to convert this water heater for use with a different type of gas other than the type shown on the rating plate. Such conversion could result in hazardous operating conditions. Please have a professional connect the gas pipe.

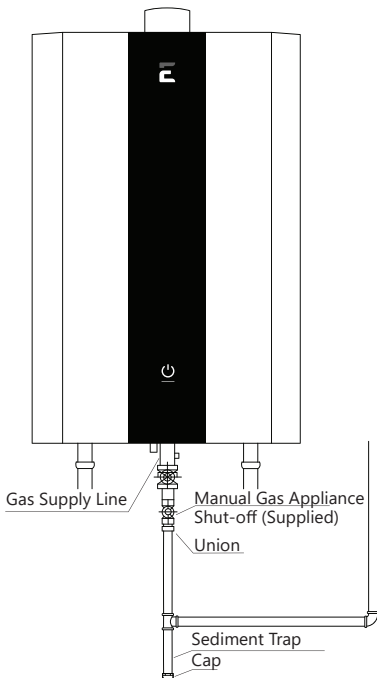

The supplied Manual Gas Appliance Shutoff Valve must be installed at the gas connection of the water heater at the time of installation (see diagram to the left).

The branch gas supply line to the water heater should be clean black steel pipe or other approved gas piping material. It is recommended that the flex gas line should be 3/4" to 1" black steel, with a minimum BTU rating of 160,000 BTUs.

A ground joint union or ANSI design certified semi-rigid or flexible gas appliance connector should be installed in the gas line close to the water heater.

The National Fuel Gas Code (NFGC) mandates a manual gas

shut off valve: See (NFGC) for complete instructions. A sediment trap should be installed at the bottom of the gas line. The inlet gas pressure to the water heater must not exceed 10.5 in. w.c. for natural or 13.5 in. w.c. for LPG. For purposes of input adjustment, the minimum inlet gas pressure (with main burner on) is shown on the water heater rating plate. If high or low gas pressures are present, contact your gas supplier for correction.

The water heater and its be disconnected from the gas supply piping system during any pressure testing of that system at test pressures in excess of 1/2 psi (3.5 kPa). The water heater must be isolated from the gas supply piping system by closing during any pressure testing of the gas supply piping system at test pressures equal to or less than 1/2 psi (3.5 kPa).

DO NOT use excessive force (over 31.5 ft lbs.) in tightening the pipe, particularly if pipe compound is used, as the water heater may be damaged. Compound used on the threaded joints of the gas piping must be of the type resistant to the action of LPG. Use compound sparingly and use on male threads only.

PLEASE NOTE: SH12-A IS FOR INDOOR PERMANENT INSTALLATIONS ONLY. THIS MANUAL AND ALL ECCOTEMP CONTENT IS SUBJECT TO CHANGE WITHOUT NOTICE. PLEASE VISIT SUPPORT.ECCOTEMP.COM FOR MORE INFORMATION.

INSTALLING THE SH12-A

RELIEF VALVE

A new pressure relief valve, complying with the standard for relief valves and automatic gas shut off devices for hot water supply systems, ANSI Z21.22, must be installed at the hot water outlet connection of the water heater at the time of installation. Local codes shall govern the installation of relief valves.

For safe operation of the water heater, be sure that:

- The pressure rating of the relief valve must not exceed 150 psi, the maximum working pressure of the water heater as marked on the rating plate.
- The BTUH rating of the relief valve must equal or exceed the BTUH input of the water heater as marked on its rating plate.
- No valve of any type should be installed between the relief valve and the water heater.
- Discharge from the relief valve should be piped to a suitable drain to eliminate potential water damage. Piping used should be of a type approved for the distribution of hot water.
- Hot and cold water lines should be insulated up to the water heater.
- The discharge line must be **NO SMALLER** than the outlet of the valve and must pitch downward to allow complete drainage (by gravity) of the relief valve and discharge line.
- The end of the discharge line should not be threaded or concealed and should be protected from freezing. No valve of any type, restriction or reducer coupling should be installed in discharge line.

⚠ NOTICE: The diagram below illustrates a pressure only relief valve. If local codes require a combination temperature and pressure relief valve be installed, an extension piece may be needed.

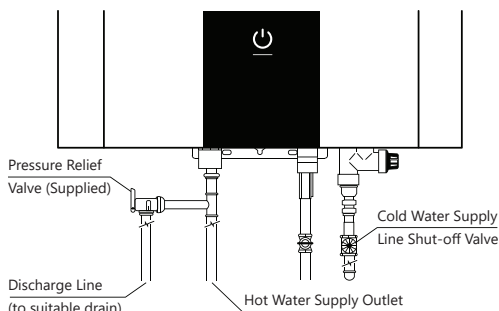

⚠ NOTICE: Local codes govern the installation of relief valves. If local codes require that a temperature and pressure relief valve should be installed the manufacturer recommends a type 40XL Watts T&P relief valve or an equivalent model be used.

⚠ NOTICE: Manual operation of relief valves should be performed at least once a year. Turn off the electrical power and gas shut off valve. Lift and release lever on the relief valve and check the manual operation of the relief valve. You should take precaution to avoid contact with the hot water coming out of the relief valve and to prevent water damage.

⚠ NOTICE: If the relief valve on the system discharges periodically, this may be due to thermal expansion in a closed water supply system. Contact the water supplier or local plumbing inspector on how to correct this situation. Do not plug the relief valve.

LEAK TESTING

⚠ WARNING: Never use an open flame to test for gas leaks, as property damage, personal injury, or death could result.

The water heater and its gas connections must be leak tested at normal operating pressures before it is placed in operation.

- Turn on the gas shut off valve(s) to the water heater.
- Use a commercial leak detector or soapy water solution to test for leaks at all connections and fittings. Bubbles indicate a gas leak that must be corrected.

All connections should also be leak tested after the water heater is placed in operation.

PRESSURE TESTING THE GAS SUPPLY SYSTEM

⚠ WARNING: Install a gas pressure regulator, in the gas supply line, which does not exceed the maximum supply pressure. DO NOT use an industrial type gas regulator.

The water heater must be isolated from the gas piping system by closing the manual gas shut off valve during any pressure testing of the gas supply piping at pressures equal to or less than 1/2 psi (14'w.c.).

HIGH ALTITUDE

The Eccotemp SH12-A SMARTHOME Indoor Gas Tankless Water Heater has been tested for use at elevations up to 2000 ft.

Installation and use of the Eccotemp SH12-A above 2000 ft. may effect overall efficiency and performance.

PLEASE NOTE: SH12-A IS FOR INDOOR PERMANENT INSTALLATIONS ONLY. THIS MANUAL AND ALL ECCOTEMP CONTENT IS SUBJECT TO CHANGE WITHOUT NOTICE. PLEASE VISIT SUPPORT.ECCOTEMP.COM FOR MORE INFORMATION.

INSTALLING THE SH12-A

VENTING

The installation of venting must comply with national codes, local codes, and the vent manufacturer's instructions. Owner must refer to vent manufacturer's instructions and specifications. Eccotemp information can be found at www.eccotemp.com.

The water heater must be vented to the outdoors as described in these instructions. **DO NOT** connect this water heater to an existing vent or chimney, it must be vented separately from all other appliances.

Eccotemp also recommends adding a backflow preventer to keep freezing outside air from reaching the water heater. Consult with an installation professional for proper installation.

All vent components (adapters, pipe, elbows, terminals, etc.) should be UL 1738 Certified Stainless Steel Venting material (e.g. AL29-4C).

The specified vent termination must be used. The termination should be a 90° elbow type with screen. (Refer to page 24). Use a vent pipe with an antidisconnection structure.

The use of a high temperature silicone (500° F) may be required to seal vent connections. To prevent accidental gas exhaust leakage, apply a 1/4" wide bead approximately 1/4" from the end and another bead against the joint side of the stop bead.

Follow vent manufacturer's installation instructions. The water heater can be vented either horizontally or vertically.

Vent pipe runs must be adequately supported along both horizontal and vertical runs.

The maximum recommended unsupported span should be no more than five (5) feet. Support isolation hanging bands should be used. **DO NOT** use wire. (See diagram below).

⚠ DANGER: Failure to install the vent adapter and properly vent the water heater to the outdoors as outlined in the Venting section of this manual will result in unsafe operation of the water heater causing death, serious injury, explosion, or fire. To avoid the risk of fire, explosion, or asphyxiation from carbon monoxide, **NEVER** operate the water heater unless it is properly vented and has adequate air supply for proper operation as outlined in the Venting section of this manual.

⚠ WARNING: Use UL approved Category III Stainless Steel vent material only. No other vent material is permitted. Owner must refer to vent manufacturer's instructions and specifications. Eccotemp information can be found at www.eccotemp.com.

⚠ WARNING: Refer to pages 13-15 for clearances to combustible material.

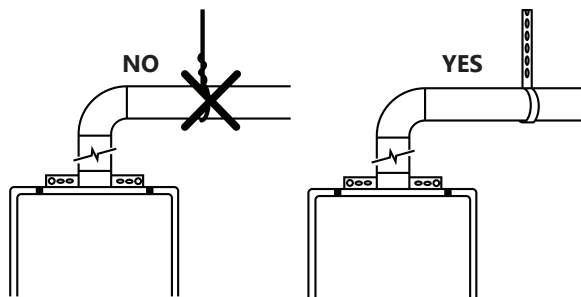

VENTING THROUGH CLOSED SPACES

If the vent piping passes through a closed space, wrap the vent pipe with inflammable insulation material that is at least 3/4" thick. **DO NOT** let the insulation material make contact with flammable materials. A minimum clearance of 6" between the vent pipe and ceiling should be maintained. Follow local codes.

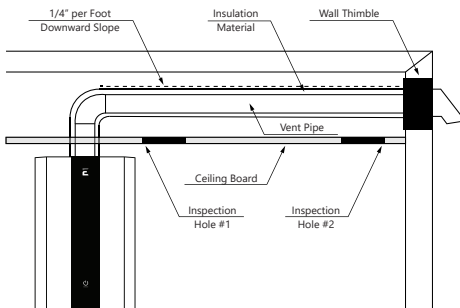

For maintenance and inspection purposes, the following holes are required to be made:

- Two (2) inspection openings that allow access to venting. One (1) of these openings should be close to where the vent pipe enters the ceiling. The other opening should never be near the vent termination.
- A ventilation hole with a 16 sq. in. opening should be made at least every 10 ft.

⚠ NOTICE: Vent pipes must be completely insulated with inflammable material when installed in alcoves, closets, and garages and must not touch any flammable material.

PLEASE NOTE: SH12-A IS FOR INDOOR PERMANENT INSTALLATIONS ONLY. THIS MANUAL AND ALL ECCOTEMP CONTENT IS SUBJECT TO CHANGE WITHOUT NOTICE. PLEASE VISIT SUPPORT.ECCOTEMP.COM FOR MORE INFORMATION.

INSTALLING THE SH12-A

VENTING LENGTHS

MAXIMUM VENT LENGTH

Owner must refer to vent manufacturer's instructions and specifications. Venting information can be found at www.eccotemp.com.

Number of 90° elbows (bends)	Maximum Length of Straight Pipe
1	32'
2	27'
3	22'

One (1) 90° Elbow is Equivalent to 5 Feet of Straight Pipe

The system will not operate if there is excessive restriction (pressure drop) in the venting system. A maximum of 32 feet of vent pipe may be used provided there is only one 90° elbow in the system. If additional elbows are required: two elbows can be used with 27 feet, and three elbows can be used with 22 feet of vent pipe.

A 90° elbow is equivalent to 5 feet of straight pipe. A 45° elbow is equivalent to 2 feet 6 inches of straight pipe. The termination elbow does not count as an elbow when determining total vent lengths.

The vent must be installed with a slight downward slope of 1/4" per foot of horizontal run toward the vent terminal (see diagram below). This ensures that any condensate formed during operation is evacuated from the water heater.

A 1/4" per foot upward slope is acceptable when it is not possible to vent with a downward slope, however, a UL approved Category III Stainless Steel condensate trap MUST be installed at the beginning of the horizontal run (See page 19 "Typical Horizontal Termination w/ 1/4" per foot UPWARD Slope" or page 24, "Standard Vertical Category III Stainless Steel" for examples).

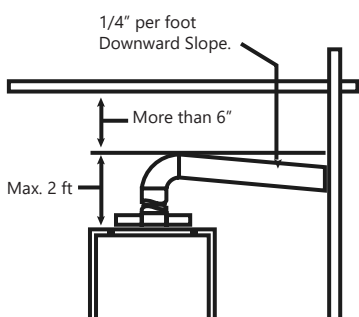
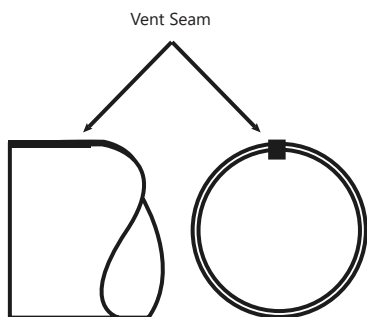

MINIMUM VENT LENGTH

The venting may be as short as 12", provided one vent termination is installed to the outdoors through a sidewall, one 90° elbow is included in the installation, and the wall thimble is installed.

▲ NOTICE: Make sure that the seam of the vent pipe in horizontal runs is toward the top of the installation (see illustration to the left).

DRAINING THE CONDENSATE

In certain conditions, installations in unconditioned space or having long horizontal or vertical runs may accumulate condensate.

Condensate is known to be acidic; refer to local, state (provincial) or federal codes for proper handling methods.

In order to prevent condensate from draining back into the water heater, we recommend a condensate trap and drain to be installed in a horizontal vent section as close as practical to the water heater vent connection.

Not following proper condensate procedures will void warranty.

Eccotemp also recommends adding a backflow preventer to keep freezing outside air from reaching the water heater. Consult with an installation professional for proper installation.

PLEASE NOTE: SH12-A IS FOR INDOOR PERMANENT INSTALLATIONS ONLY. THIS MANUAL AND ALL ECCOTEMP CONTENT IS SUBJECT TO CHANGE WITHOUT NOTICE. PLEASE VISIT SUPPORT.ECCOTEMP.COM FOR MORE INFORMATION.

INSTALLING THE SH12-A

SPECIAL NOTES, REGULATIONS, AND CAUTIONS REGARDING VENTING

For Category II, III and IV water heaters, the venting system shall be installed in accordance with the water heater manufacturer's instructions and, if applicable, the venting system manufacturer's instructions. The SH12-A is a Category III water heater. Please find detailed instructions for installation of the SH12-A and venting on pages 19-26.

The instructions for the installation of the venting system shall specify that the horizontal portions of the venting system shall be supported to prevent sagging; the methods of and intervals for support shall be specified. These instructions shall also specify that the venting system: ii) for Category III and IV appliances, slope of a horizontal venting system shall be as specified in the appliance manufacturer's instructions; These instructions can be found on page 24.

If an appliance is marked, "Category III", the installation manuals shall specify the venting system to be used on page 25-26.

When an existing Category III appliance is removed or replaced, the original venting system may no longer be sized to properly vent the attached appliances. Instructions shall also indicate effects of an improperly sized venting system (formation of condensate, leakage, spillage, etc.) All approved Installation Instructions for the SH12-A can be found on pages 19-26.

Be sure to periodically clean the screens in the vent terminal where applicable.

Before you begin installation, ensure that you have a vent port available that will terminate at least 12 inches above the ground and at least 12 inches above normal amounts of snow. Please ensure that the vent termination point is clear of debris, blockages, and snow before using the SH12-A.

INSTALLING THE SH12-A

VENTING

Vent Termination Clearances
for Non-Direct Vent Installations in the US and Canada

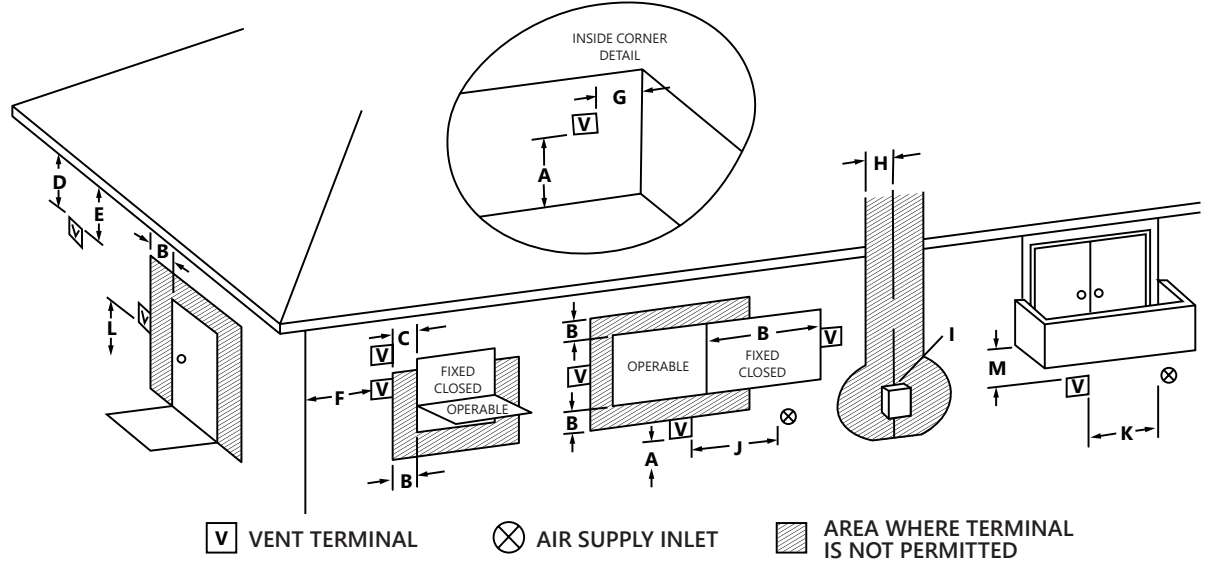

		US Installations	Canadian Installations
A =	Clearance above grade, veranda, porch, deck, or balcony.	12 in (30 cm)	12 in (30cm)
B =	Clearance to window or door that may be opened.	4 ft (1.2m) below or to the side of opening; 1 ft (300 mm) above opening.	6in (15cm) for appliances ≤ 10,000 BTUH (3 Kw), 12 in (30 cm) for appliances > 10,000 BTUH (3kW) and ≤ 100,000 BTUH (30kW), 36 in (91 cm) for appliance > 100,000 BTUH (30kW).
C =	Clearance to permanently closed window.	*	
D =	Vertical Clearance to ventilated soffit located above the terminal within a horizontal distance of 2 feet (61 cm) from the center line of the terminal.	*	
E =	Clearance to unventilated soffit.	*	

PLEASE NOTE: SH12-A IS FOR INDOOR PERMANENT INSTALLATIONS ONLY. THIS MANUAL AND ALL ECCOTEMP CONTENT IS SUBJECT TO CHANGE WITHOUT NOTICE. PLEASE VISIT SUPPORT.ECCOTEMP.COM FOR MORE INFORMATION.

INSTALLING THE SH12-A

VENTING

F =	Clearance to outside corner.	*	
G =	Clearance to inside corner.	*	
H =	Clearance to each side of center line extended above meter / regulator assembly.	*	3 ft (91 cm) within a height 15 ft above the meter / regulator assembly.
I =	Clearance to service regulator vent outlet.	*	3 ft (91 cm)
J =	Clearance to non mechanical air supply inlet to building or the combustion air inlet to any other appliance.	4 ft (1.2 m) below or to side of opening; 1 ft (300 mm) above opening.	6 in (15 cm) for appliances ≤ 10,000 BTUH (3kW), 12 in (30cm) for appliances > 10,000 BTUH (3kW) and ≤ 100,000 BTUH (30kW), 36 in (91 cm) for appliances > 100,000 BTUH (30kW).
K =	Clearance to a mechanical air supply inlet.	3 ft (91 cm) above if within 10 ft (3 cm) horizontally.	6 ft (1.83 m)
L =	Clearance above paved sidewalk or paved driveway located on public property.	*	7 ft (2.13 m)
M =	Clearance under veranda, porch, deck, or balcony.	*	12 in (30 cm)

* For clearances not specified in ANSI Z=Z223.1 / NFPA 54 or CSA-B149.1, one of the following shall be indicated;

- A) A minimum clearance value determined by testing in accordance with Clause 5.20, or;
- B) A reference to the following footnote:

“Clearance in accordance with local installation codes and the requirements of the gas supplier.”

- A vent shall not terminate directly above a sidewalk or paved driveway that is located between two single family dwellings and serves both dwellings.
- Permitted only if veranda, porch, deck, or balcony is fully open on a minimum of two sides beneath the floor.

Notes:

- In accordance with the current CSA B149.1 Natural Gas and Propane Installation Code.
- In accordance with the current ANSI Z223.1 / NFPA 54 National Fuel Gas Code.

INSTALLING THE SH12-A

VENTILATION PARTS

Owner must refer to vent manufacturer's instructions and specifications by visiting www.eccotemp.com. Installation guidelines for venting is provided by Eccotemp, who is solely responsible for venting installation accuracy.

Eccotemp parts are available for purchase by visiting www.eccotemp.com.

Eccotemp Installation Instructions:
www.support.eccotemp.com

Part #	Description	SKU#	Description
SH12-A 90 Degree Elbow	Stainless Steel 90 Elbow	1200031	90 Degree Elbow
Eccotemp 3" Horizontal Vent Kit	Stainless Steel Horizontal Vent Kit	V3HVK	3" Vent Kit Horizontal
Eccotemp 3" Vertical Vent Kit	Stainless Steel Vertical Vent Kit	V3VVK	3" Vent Kit Vertical
SH12-A TERMINATION PIPE	Stainless Steel Termination Pipe	1001029	SH12-A Termination Pipe
SH12-A Wall Thimble Replacement	Stainless Steel Wall Thimble	1200034	SH12-A Wall Thimble
SH12-A 18" Vent Extension	Stainless Steel Vent Extension 18"	12000300	SH12-A 18" Vent Extension

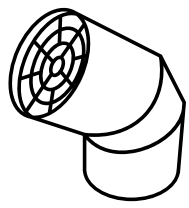

90° Termination
Part #1200031

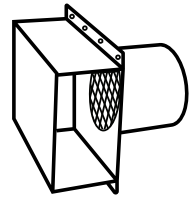

Termination Box
Part #2SVSTB03

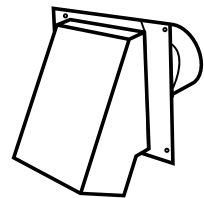

Termination Hood
Part #1200034

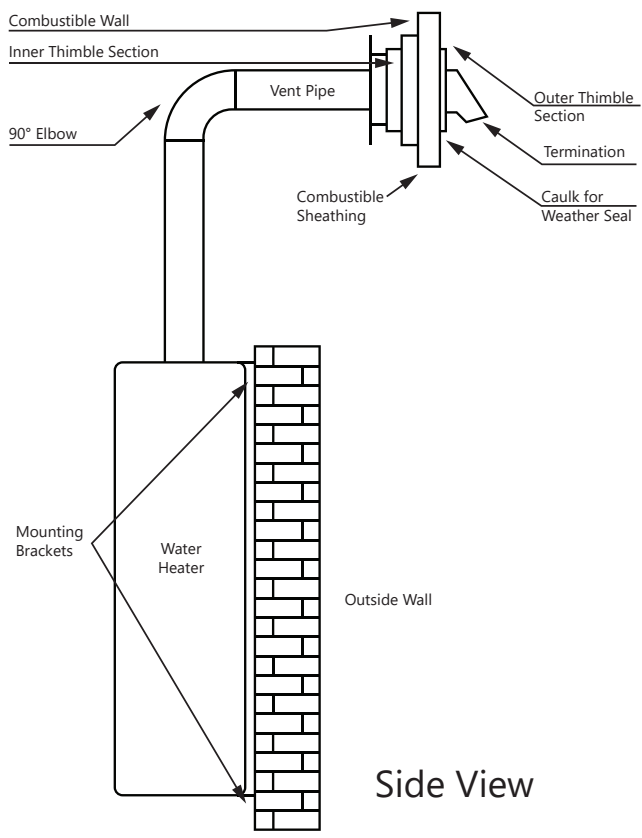

Side View

PLEASE NOTE: SH12-A IS FOR INDOOR PERMANENT INSTALLATIONS ONLY. THIS MANUAL AND ALL ECCOTEMP CONTENT IS SUBJECT TO CHANGE WITHOUT NOTICE. PLEASE VISIT SUPPORT.ECCOTEMP.COM FOR MORE INFORMATION.

INSTALLING THE SH12-A

VENTING

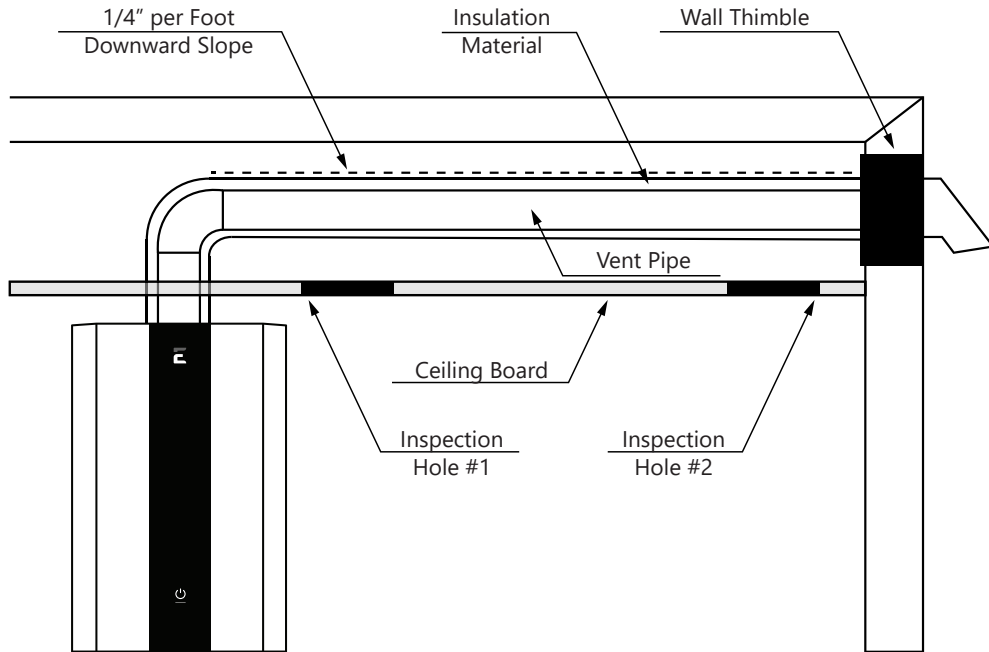

⚠ WARNING: Use UL approved Category III vent material only. No other vent material is permitted. Owner must refer to vent manufacturer's instructions and specifications. Venting information can be found at www.eccotemp.com.

⚠ CAUTION! Follow the vent manufacturer's installation instructions as design might vary from manufacturer to manufacturer.

COMPONENTS FOR LOW TEMPERATURE OPERATION

In Canada, all components and/or controls affecting the safety of the appliance shall be individually certified for the lower ambient operating temperature of the outdoor appliance, or enclosed in a supplementary heated compartment.

All operating components and or controls not affecting the safety of the appliance will be reviewed for their acceptance in the particular application, bearing in mind their certified temperature limitations and the affect that any malfunction may produce.

The heated compartment shall not rely solely on recirculating air for supplementary heat. It is not advised to operate the water heater if the ambient temperature is at or below 32°F/0°C to prevent damage to the water heater, to property, or to people.

PLEASE NOTE: SH12-A IS FOR INDOOR PERMANENT INSTALLATIONS ONLY. THIS MANUAL AND ALL ECCOTEMP CONTENT IS SUBJECT TO CHANGE WITHOUT NOTICE. PLEASE VISIT SUPPORT.ECCOTEMP.COM FOR MORE INFORMATION.

INSTALLING THE SH12-A

VENTING CONT.

Only the 3" vent kit (purchase separately) for the SH12-A or approved Ecotemp Stainless Steel venting should be used for installation. The wall thimble requires mechanical support from the wall sufficient to support any incidental loads on the system. If the wall is not sufficient enough to support the wall thimble, then appropriate additional framing and/or blocking is required.

INSTALLATION PROCEDURE:

Prepare an opening for the wall thimble in the wall. The opening must be 6.5" in diameter for a 3" vent system. The opening should be round.

The opening must be able to accommodate the 3" vent system and wall thimble (purchased separately). Consult manual or building codes for distance from flammable materials.

The wall thimble is designed to adapt to any wall thickness from 3.5" to 6" thick. If the wall is thicker than 6" the wall thimble may be extended using a piece of 6" diameter snaplock or welded seam galvanized pipe up to 6" long.

Select the larger diameter half of the wall thimble for the outside of the wall.

- Apply a continuous bead of high quality silicone or silicone/latex caulk on the inside of the outer flange. This will be the only weather seal to keep moisture outside the building. Ensure a sufficient seal is made.
- Position this portion of the wall thimble into the prepared hole from the outside. Secure the assembly into the prepared opening using fasteners as indicated by sheathing or structural members, sealing the screw heads with more caulking.
- Use 4 hollow wall anchors, at least 1/8" in diameter and of appropriate length for the thickness of the sheathing, if sheathing is particle board or other composite material. Use 4 #10x1-1/4" wood screws for plywood, solid wood sheathing or members. Use suitable masonry anchors when passing through solid masonry walls. Reinstall the decorative sheathing around the wall thimble. This assembly may be painted to match the exterior decor.
- Slide the interior portion of the thimble into the inside hole. Be certain the interior and exterior thimble halves overlap at least 1". If insufficient overlap exists, extend the interior portion with single wall galvanized pipe.
- Secure the vent section that protrudes through the wall thimble to the 90° elbow attached to the water heater.
- The exhaust pipe should be sloped downward at an approximate 3° grade in order to avoid rain (or condensation entering the heater) through the exhaust pipe.

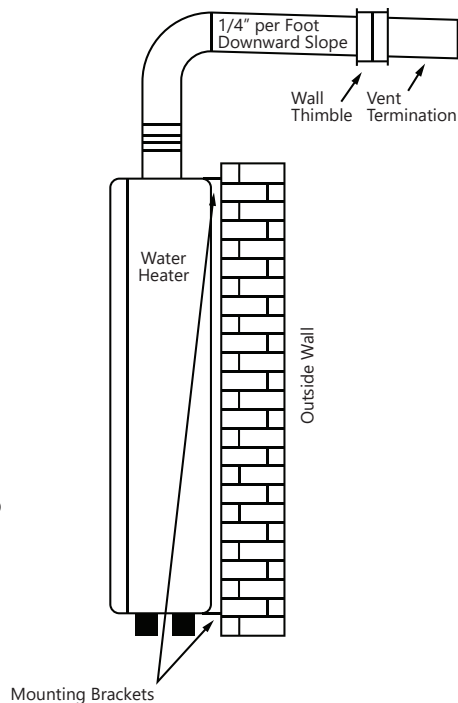

Side View

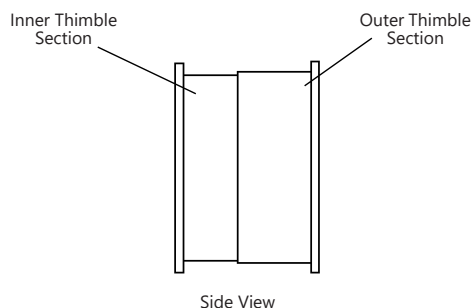

Side View

PLEASE NOTE: SH12-A IS FOR INDOOR PERMANENT INSTALLATIONS ONLY. THIS MANUAL AND ALL ECCOTEMP CONTENT IS SUBJECT TO CHANGE WITHOUT NOTICE. PLEASE VISIT SUPPORT.ECCOTEMP.COM FOR MORE INFORMATION.

INSTALLING THE SH12-A

ELECTRICAL CONNECTIONS

⚠ WARNING: Field wiring connections and electrical grounding must comply with local codes, or in the absence of local codes, with the latest edition of the National Electrical Code, ANSI/NFPA 70, or in Canada, Canadian Electrical Code, CSA C22.1Part1.

ELECTRICAL CONNECTION POWER CORD:

- The electric power supply requirement for this water heater is 120 VAC/60HZ, 2 Amps.
- The water heater comes with a three (3) pin power supply cord. Use only a power outlet with a ground terminal.
- Do NOT cut the power cord!

THIS WILL VOID THE WARRANTY!

- The installation of an electric leakage breaker is recommended. (GFCI)
- Keep any excess of the power supply cord on the outside of the water heater.

⚠ WARNING: Shock hazard line voltage is present. Before servicing the water heater, turn off the electrical power to the water heater at the main disconnect or circuit breaker. Failure to do so could result in severe personal injury or death.

⚠ CAUTION: Label all wires prior to disconnection when servicing controls. Wiring errors can cause improper and dangerous operation. Verify correct operation after servicing.

ELECTRIC WIRING DIAGRAM

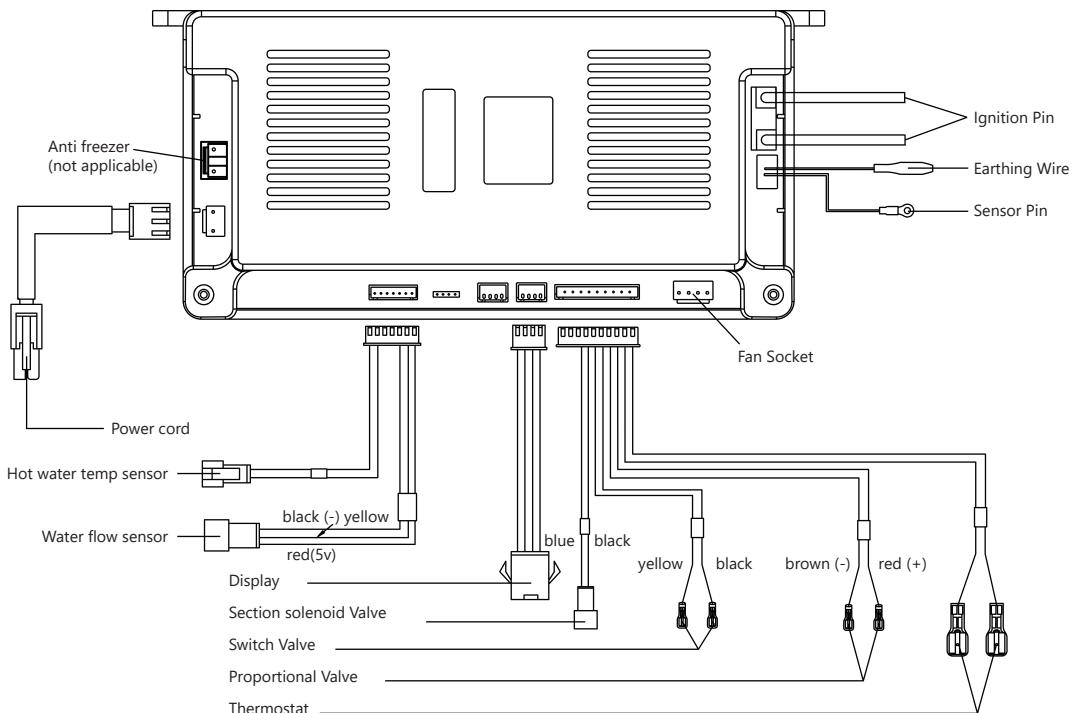

PLEASE NOTE: SH12-A IS FOR INDOOR PERMANENT INSTALLATIONS ONLY. THIS MANUAL AND ALL ECCOTEMP CONTENT IS SUBJECT TO CHANGE WITHOUT NOTICE. PLEASE VISIT SUPPORT.ECCOTEMP.COM FOR MORE INFORMATION.

INSTALLING THE SH12-A

INSULATION BLANKETS

Insulation blankets, available to the general public, for external use on gas water heaters are not necessary. The purpose of an insulation blanket is to reduce the standby heat loss encountered with storage tank heaters. This water heater does not store water making an insulation blanket unnecessary.

The manufacturer's warranty does not cover any damage or defect caused by installation, attachment or use of any type of energy saving or other unapproved devices (other than those authorized by the manufacturer) into, onto or in conjunction with the water heater. The use of unauthorized energy saving devices may shorten the life of the water heater and may endanger life and property. The manufacturer disclaims any responsibility for such loss or injury resulting from the use of such unauthorized devices.

⚠ WARNING: If local codes require external application of insulation blanket kits the manufacturer's instructions included with the kit must be carefully followed.

PIPE INSTALLATION

Inlet Pipe and Outlet Pipe Installation

Use pressure resistant pipe to connect the inlet and outlet water pipes of the water heater and the local water pipe (make sure to place the rubber ring). Before connecting the inlet water pipe, flush the inside of the pipe.

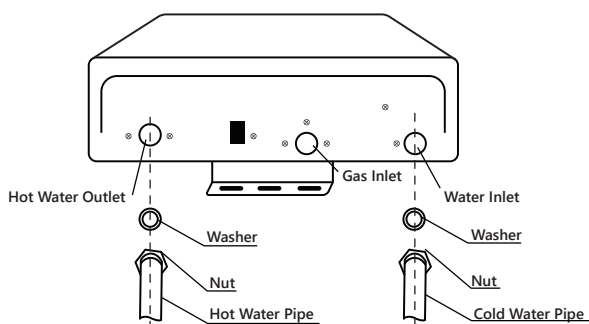

Hot and Cold Pipe Insulation Installation

For increased energy efficiency, use pipe insulation. Please install the insulation, according to the illustrations above, making sure to insulate all the way to the top. Do not cover any drain or pressure valve(s).

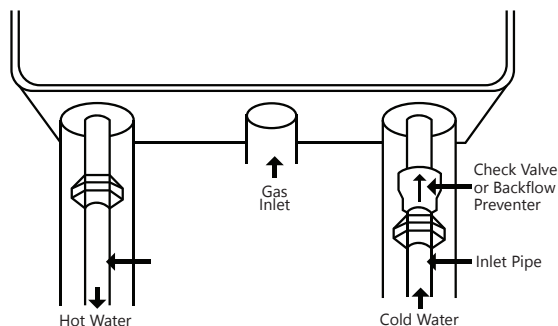

⚠ NOTICE: The hot and cold pipes should be insulated as shown to help provide additional freeze protection.

DURING INSTALLATION OF THIS WATER HEATER:

Do's

- **DO** check inlet gas pressure to ensure that it is within the range specified on the rating plate.
- **DO** provide adequate air for combustion and ventilation as discussed in the Use & Care Manual and the National Gas Code (CAN/CGA B 149 in Canada).
- **DO** maintain proper clearances to combustibles as specified by applicable code.
- **DO** ensure that the flue terminal location complies with the guidelines found in the Use & Care Manual and National Fuel Gas Code (CAN/CGA B 149 in Canada).

Dont's

- **DON'T** block or restrict air intake opening located on the back side of the water heater.
- **DON'T** remove the front cover unless absolutely necessary. This should only be done after being examined by a qualified service technician.
- **DON'T** install this product where standing water may occur.

PLEASE NOTE: SH12-A IS FOR INDOOR PERMANENT INSTALLATIONS ONLY. THIS MANUAL AND ALL ECCOTEMP CONTENT IS SUBJECT TO CHANGE WITHOUT NOTICE. PLEASE VISIT SUPPORT.ECCOTEMP.COM FOR MORE INFORMATION.

INSTALLING THE SH12-A

MOUNTING

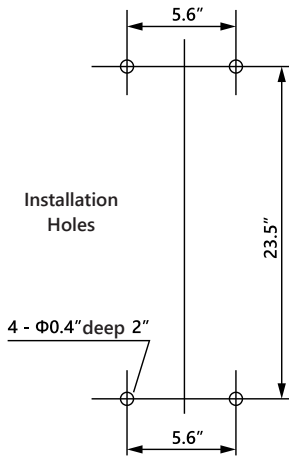

Make sure the location of the water heater allows for easy access and operation.

In case of dry wall, or concrete wall use dry wall anchors or lag bolts.

The water heater requires 120VAC/ 60Hz. Have a receptacle with ground terminal near the water heater. The length of the power supply cord is 5 feet.

Drill the holes as per the sizes in the figure to the left, put 2 expansion screws into the top holes, and 2 rubber screws into the bottom holes.

Hang up the water heater, tighten the expansion screws, and put 2 wood thread screws into the bottom holes.

⚠ CAUTION: Reinforcement of the wall is required in case the wall is not strong enough to hold the water heater.

Indoor water heater must be installed with CAT 3 vent pipe in accordance with vent supplier/manufacturer in accordance with local code.

Owner must refer to vent manufacturer's instructions and specifications. Ecotemp information can be found at www.ecotemp.com.

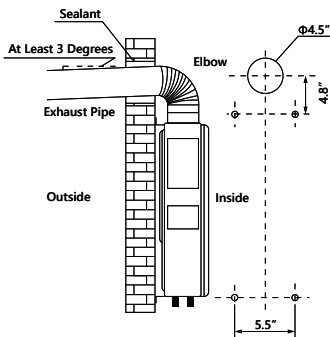

Back Installation

A. BACK INSTALLATION

1. Insert the vent pipe through the installation holes in the wall with the terminal sticking out.
2. Connect the elbow to the vent pipe and water heater, moving straight backwards until the expansion screws go into the holes of the water heater. Screw the nuts tight (pay attention to the direction of the elbow).

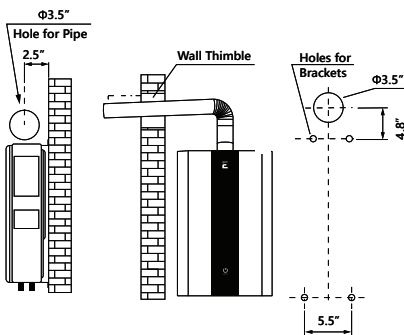

Side Installation

B. SIDE INSTALLATION

1. Aim the holes in the water heater onto the expansion screws, hang it up and screw the nuts tightly.
2. Put the vent pipe through the holes in the wall, and connect the elbow with the water heater and vent pipe.

C. VERTICAL INSTALLATION

1. Please refer to local installation professional or venting manufacturer.
2. The installation hole in the wall needs to be sealed by fire-retardant material or wall thimble, making sure the water heater is tight and will not come off.

PLEASE NOTE: SH12-A IS FOR INDOOR PERMANENT INSTALLATIONS ONLY. THIS MANUAL AND ALL ECOTEMP CONTENT IS SUBJECT TO CHANGE WITHOUT NOTICE. PLEASE VISIT SUPPORT.ECOTEMP.COM FOR MORE INFORMATION.

INSTALLING THE SH12-A

CHECKLIST

Water Heater Location

- Installed **INDOORS**.
- Close to area of mostly used outlet.
- Protected from freezing temperatures.
- Proper clearance from combustible surfaces observed.
- Sufficient fresh air supply for proper operation of water heater.
- Air supply free of corrosive elements and flammable vapors.
- Provisions made to protect area from water damage.
- Sufficient room to service heater.
- Combustible materials, such as clothing, cleaning materials, rags, etc. clear of the heater and vent piping.
- Water heater is properly attached to the wall.

Water Supply

- Water supply has sufficient pressure.
- Air purged from water heater and piping.
- Water connections tight and free of leaks.
- Water filter is clean and in place.
- Materials are used as instructed in this manual.
- Water pipes are insulated.

Gas Supply

- Gas type matches rating plate.
- Gas supply pressure is sufficient for the water heater.
- Gas line equipped with shut-off valve, union and sediment trap.
- Approved pipe joint compound used.
- Commercial leak detector or soap and water solution used to check all connections and fittings for possible gas leak.
- Gas company inspected installation (if required).

Relief Valve

- Pressure Relief Valve properly installed and discharge line run to open drain.
- Discharge line protected from freezing.

Electrical Wiring

- Voltage matches rating plate.
- Water heater is properly grounded.
- Wiring meets all local codes.
- GFCI Protection where required.

OPERATING INSTRUCTIONS

START INSTRUCTIONS

Before operating this water heater, be sure to read and follow the instructions on the label pictured below and all other labels on the water heater, as well as the warnings printed in this manual. Failure to do so can result in unsafe operation of the water heater resulting in property damage, personal injury, or death. Should you have any problems reading or following the instructions in this manual. **STOP**, and get help from a qualified person.

BEFORE USING THE WATER HEATER FOR YOUR SAFETY

Warning: If you do not follow these instructions exactly, A FIRE OR EXPLOSION MAY RESULT CAUSING PROPERTY DAMAGE, PERSONAL INJURY OR LOSS OF LIFE.



FOR YOUR SAFETY

- Not to be used as a pool heater
 - Suitable only for outdoor installation
 - **DO NOT** operate this appliance before leak checking hoses and gas cylinder connection
 - To be installed on non-combustible base
1. This water heater does not have a pilot. It is equipped with an ignition device which automatically lights the burner. Do not try to light the burner by hand.
 2. **BEFORE OPERATING** smell all around the water heater area for gas. Be sure to smell next to the floor because some floor because some gas is heavier than air and will settle on the floor. Test all connections with a commercial leak detector or soapy water.

WHAT TO DO IF YOU SMELL GAS:

- **DO NOT** try to light any appliance
 - **DO NOT** touch any electric switch
 - **DO NOT** use any phone in your building
 - Immediately call your gas supplier from a neighbor's phone
 - Follow the gas supplier's instructions
 - If you cannot reach your gas supplier or fire department **DO NOT** return to your home
 - **ONLY** return to your home once your gas supplier or fire department authorized it.
3. Use only your hand to push or turn the gas control knob. Never use tools. If the knob will not push in or turn by hand, don't try to repair it, call a qualified technician. Force or attempt to repair may result in a fire or explosions.
 4. **DO NOT** use this water heater if any part has been under water. Immediately call a qualified service technician to inspect the water heater and to replace any part of the control system and any gas control which has been under water.

OPERATING INSTRUCTIONS

1. **STOP!** Read the safety information above on this label.
2. Turn off all electric power to the appliance.
3. Set the thermostat to lowest setting.
4. **DO NOT** attempt to light the burner by hand.
5. Turn the Gas Shut-Off Valve located on the outside of the unit clockwise  to the "OFF" position.
6. Wait five (5) minutes to clear out any gas. If you smell gas, **STOP!** Follow "B" in the safety information above on this label. If you don't smell gas, go to the next step.
7. Turn the Gas Shut-Off Valve located on the outside of unit counterclockwise  to the "ON" position.
8. Turn on all electric power to the appliance.
9. Set thermostat to desired setting.
10. If the appliance will not operate, follow the instructions "To Turn Off Gas To Appliance" and call your service technician or gas supplier.

GAS SHUT-OFF VALVE

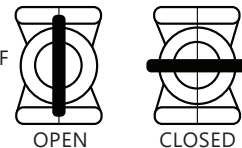

OPEN

CLOSED

TO TURN OFF GAS TO APPLIANCE

1. Turn off all electric power to the appliance if service is to be performed.
2. Turn the Gas Shut-Off Valve located on the outside of the unit clockwise  to the "OFF" position.

PLEASE NOTE: SH12-A IS FOR INDOOR PERMANENT INSTALLATIONS ONLY. THIS MANUAL AND ALL ECCOTEMP CONTENT IS SUBJECT TO CHANGE WITHOUT NOTICE. PLEASE VISIT SUPPORT.ECCOTEMP.COM FOR MORE INFORMATION.

OPERATING INSTRUCTIONS

TURNING ON THE WATER HEATER

1. Make sure the gas type you will use is same as the type on the data plate.
2. Turn on the main gas valve, plug in the power cord (be sure the socket is well grounded), and press the "ON/OFF" button on the control panel. Set temperature to 120°F.
3. Turn on the faucet, and the fan will begin working. You will hear the ignition sound after a few seconds. The burner will ignite, and hot water will come out. If the burner is not ignited successfully, the ignition sound will last a few seconds. If the burner still fails to ignite, turn off the faucet and wait for 10-20 seconds, and repeat the above procedures.

For the first use and/or if the water heater has not been used for a considerable period of time, the repeat of the above procedures may be required, due to accumulated air inside the gas pipe.

SAFETY PRECAUTIONS

If there is any difficulty in understanding or following the Operating Instructions or the Care and Cleaning section, it is required that a licensed professional perform the work.

- Turn off manual gas shut off valve if water heater has been subjected to over heating, fire, flood, physical damage or if the gas supply fails to shut off.
- **DO NOT** turn on water heater unless water and gas supplies are fully opened.
- **DO NOT** turn on water heater if cold water supply shut off valve is closed.
- **DO NOT** allow combustible materials such as newspaper, rags or mops to accumulate near water heater.
- **DO NOT** store or use gasoline or other flammable vapors and liquids, such as adhesives or paint thinner, in vicinity of this or any other appliance. If such flammables must be used, open doors and windows for ventilation, and all gas burning appliances in the vicinity should be shut off including their pilot lights, to avoid vapors lighting.

▲ NOTICE: Flammable vapors can be drawn by air currents from surrounding areas to the water heater.

POWER SURGE/NO NETWORK

If you experience a power surge or have network connectivity issues that are enabling connection to the Ecotemp **SMARTHOME** App, you can manually reset the water heater to the factory settings by following these steps below:

- Make sure your water heater is plugged in and has power to it.
- Turn on your water heater by touching the power icon on the front, the icon should illuminate to red.
- While the power icon is still red, press the icon for 15 seconds until the power icon turns blue.
- The water heater has now reset to the original factory settings. NO timer is set, NO schedule is set, water heater is set to 118°F
- Turn on your water heater by touching the power icon on the front, the icon should illuminate to red and you can use the water heater at it's factory preset.

OPERATING INSTRUCTIONS

WATER TEMPERATURE SETTING

Output temperature of water can be regulated by the following options: Remote control and Ecotemp **SMARTHOME** mobile APP.

Safety factors should be considered when selecting the water temperature setting of the water heater. The water heater was set at 118°F before it was shipped from the factory. This is the recommended starting point.

Water temperatures above 120°F can cause severe burns or death from scalding. The thermostat is adjusted to its lowest temperature position when shipped from the factory.

Time / Temperature Relationship in Scales	
Water Temperature	Time to Product a serious Burn
120	More than 5 minutes
125	1 1/2 to 2 minutes
130	About 30 seconds
135	About 10 seconds
140	Less than 5 seconds
145	Less than 3 seconds
150	About 1 1/2 seconds
155	About 1 second
Table courtesy of Shriners Burn Institute	

Be sure to read and follow the warnings outlined in this manual and on the label located on the water heater.

Mixing valves are available for reducing point of use water temperature by mixing hot and cold water in branch water lines.

Procedures for adjusting the thermostat for energy efficient operation at the minimum water temperature setting consistent with the consumer's needs.

Contact a licensed plumber or the local plumbing authority for further information. See page 8 for details.

⚠ DANGER: There is a hot water scald potential if the temperature is set too high. Households with small children, disabled, or elderly persons may require a 120°F or lower temperature setting to prevent contact with HOT water.

PRESET TEMPERATURE:

The Ecotemp SH12-A-LP/NG models are AUTOMATIC TEMPERATURE CONTROLLED water heaters. Select one of the preset temperatures on the SH12-As by using the Ecotemp SMARTHOME mobile app, and then adjust your sink/shower water temperature at the source/faucet. The following preset temperatures are:

LOW - 95°F **COMFORT** - 110°F
HIGH - 120°F **COMMERCIAL** - 130°F

The SH12-A Series is a flow activated water heater and should maintain at least 0.7 GPM to activate and 0.6 GPM to maintain activation.

AUTOMATIC VS. MANUAL TEMPERATURE CONTROL

The SH12-A Series is an automatic temperature controlled tankless water heater. Below explains the differences between an automatic and manual temperature controlled tankless water heater. For additional questions please visit support.ecotemp.com.

Turn water heater ON/OFF

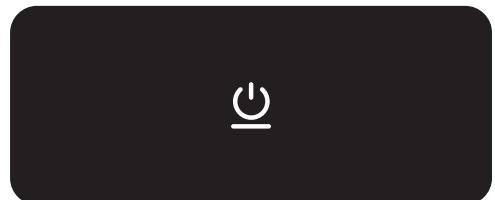

Hold the button down for 5 seconds to get into EZ connection mode (fast blink) and hold down for another 5 seconds to get into AP connection mode (slow blink) that produces a Wi-Fi hotspot to connect to.

AUTOMATIC TEMPERATURE CONTROL:

The water heater will self-adjust temperature according to what is being requested at the output water source (sink or shower). It also will regulate the temperature automatically according to how many applications are being used at the same time. Temperature doesn't have to be reset after each use.

MANUAL TEMPERATURE CONTROL:

You must adjust the temperature manually each time you use the water heater. The temperature must be adjusted according to the amount of applications being used at the same time due to the fluctuation of pressure.

⚠ NOTICE! If inlet water temperature is too high, and set temperature is low, the actual temperature might be higher than the set temperature, and vice versa.

PLEASE NOTE: SH12-A IS FOR INDOOR PERMANENT INSTALLATIONS ONLY. THIS MANUAL AND ALL ECOTEMP CONTENT IS SUBJECT TO CHANGE WITHOUT NOTICE. PLEASE VISIT SUPPORT.ECOTEMP.COM FOR MORE INFORMATION.

OPERATING INSTRUCTIONS

SH12-A REMOTE

Control your Eccotemp **SMARTHOME** water heater using the included remote.

The **SMARTHOME** remote has an easy to use control panel that allows you to control functions such as ON/OFF, temperature settings and connection modes. The remote control is compatible with your SH12-A **SMARTHOME** water heater and gives you the ability to change settings from a distance.

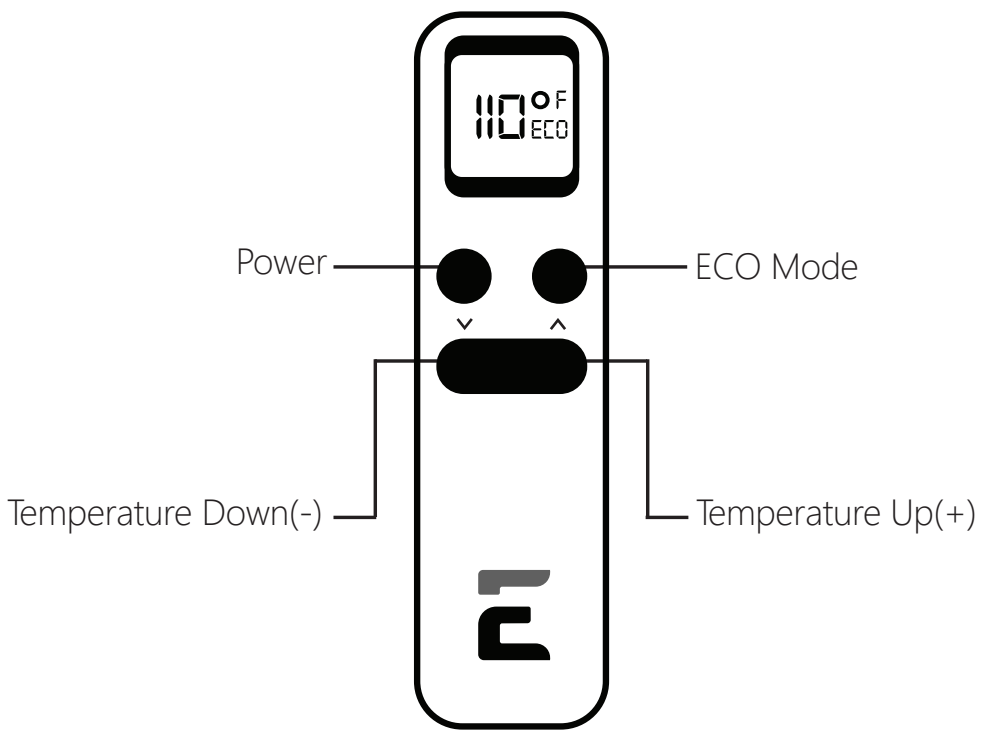

PLEASE NOTE: SH12-A IS FOR INDOOR PERMANENT INSTALLATIONS ONLY. THIS MANUAL AND ALL ECCOTEMP CONTENT IS SUBJECT TO CHANGE WITHOUT NOTICE. PLEASE VISIT SUPPORT.ECCOTEMP.COM FOR MORE INFORMATION.

OPERATING INSTRUCTIONS

ECCOTEMP SMARTHOME MOBILE APP

Connect your Eccotemp SMARTHOME tankless water heater to your Smart Devices

The Eccotemp SMARTHOME tankless water heater app lets you adjust temperature, turn Eccotemp water heaters ON/OFF, set timers and schedules, and view usage statistics. You can also connect SMARTHOME tankless water heater to technology such as Amazon Alexa and Google Assistant to use voice commands.

Once connected with Google Assistant and Amazon Alexa you will be able to use voice commands to adjust your SMARTHOME tankless water heater. A broad range of commands can be used to control water temperature, check heater status, and to set schedules and timers. Let our Eccotemp SMARTHOME app tell you exactly how much money you save heating water.



ECO Mode

This mode allows for up to 25% less gas usage when using the device.



Temperature

The temperature of the SMARTHOME water heater can be remotely changed from the Eccotemp app.



Instant Statistics

Observe water and electricity usage easily by checking the statistics page. Here you can see how much it costs to use your SMARTHOME water heater, and how much you are saving.

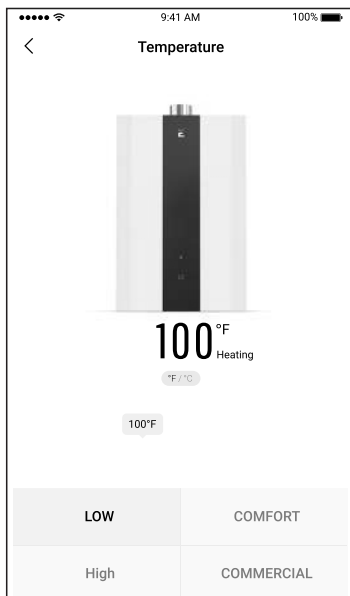
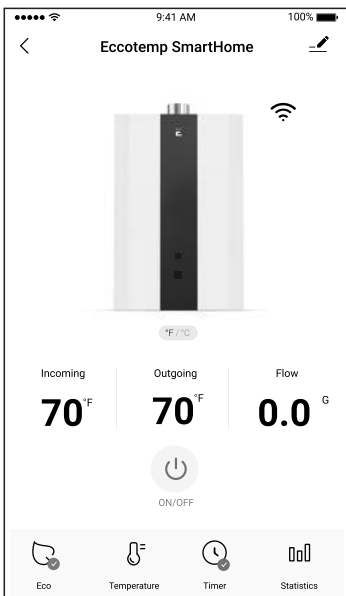

PLEASE NOTE: SH12-A IS FOR INDOOR PERMANENT INSTALLATIONS ONLY. THIS MANUAL AND ALL ECCOTEMP CONTENT IS SUBJECT TO CHANGE WITHOUT NOTICE. PLEASE VISIT SUPPORT.ECCOTEMP.COM FOR MORE INFORMATION.

OPERATING INSTRUCTIONS

SMARTHOME MOBILE APP CONT.



Timer

The timer can be used to allow hot water for set time periods, each time your **SMARTHOME** water heater is turned ON/OFF. With the scheduler, you are also able to set schedules for specific days and times to allow hot water usage.



Scheduler

When a timer and a schedule are both set, the scheduler function takes priority. Hot water is produced only during the selected schedule, regardless of the timer that is set. For example, if a timer is set to allow 15 minutes of hot water, but a schedule is also set to only allow 10 minutes of hot water on a specific day, your **SMARTHOME** water heater will stop heating water after 10 minutes on that specific day. The user can then turn the **SMARTHOME** water heater **OFF** and back **ON** again, but the water will not warm because the scheduled time to allow hot water has passed. There is a 30 second delay when setting a timer/schedule.



Error Codes

The Eccotemp **SMARTHOME** water heater app has a troubleshooter to diagnose any device errors, which will help keep your **SMARTHOME** water heater running in top shape.



Network Error

The built in network troubleshooter will tell you if there is a wifi problem.

Have a problem with your Eccotemp water heater? The Eccotemp **SMARTHOME** app can tell you exactly what the problem is. Download it today to unlock your **SMARTHOME** water heater's full capabilities. Simply search for "Eccotemp" on the Apple App Store, Google Play or scan one of the QR codes on the previous page.

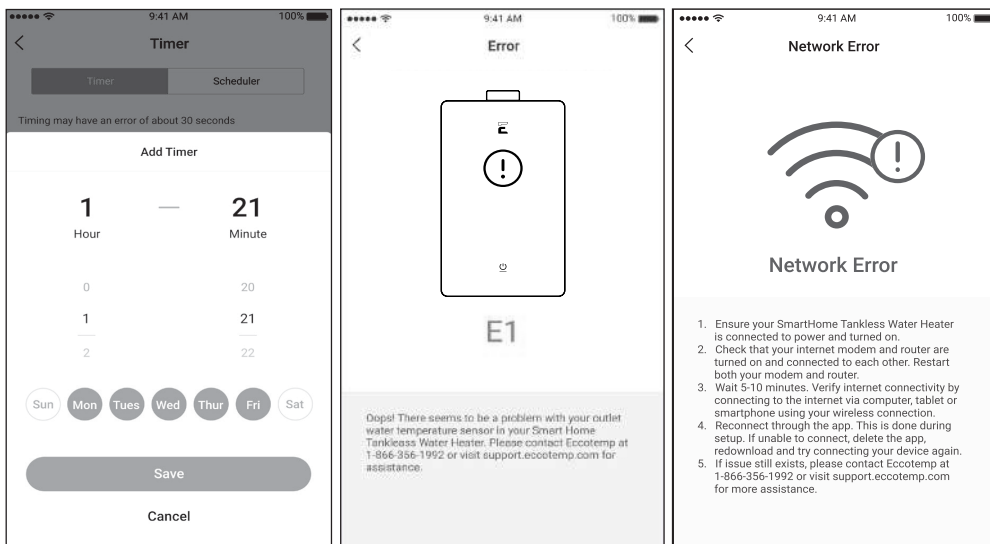

PLEASE NOTE: SH12-A IS FOR INDOOR PERMANENT INSTALLATIONS ONLY. THIS MANUAL AND ALL ECCOTEMP CONTENT IS SUBJECT TO CHANGE WITHOUT NOTICE. PLEASE VISIT SUPPORT.ECCOTEMP.COM FOR MORE INFORMATION.

OPERATING INSTRUCTIONS

SMARTHOME MOBILE APP CONT.

1. Download the App to get Started

Find and download the Eccotemp smart phone app on the Apple App Store or the Google Play Store by typing "Eccotemp" into search panel.

2. Setup and Login

Once the app is installed, create a login and connect the app to the water heater. Follow the directions on screen.

3. Using the App

After connecting the **SMARTHOME** app to your water heater, you will be able to remotely control the temperature and on/off status of the gas tankless water heater. There is an energy statistics screen that will allow you to track your usage and help you manage your water heater's energy consumption. Regularly using and reviewing the app will help you fine tune your water heating needs, while helping you use less resources to do so, ultimately saving you money.

4. Getting Connected

Connect your Eccotemp **SMARTHOME** Tankless Water Heater to other **SMARTHOME** devices like Amazon Alexa and Google Home. Once connected, the Eccotemp **SMARTHOME** Tankless Water Heater can accept voice commands such as, "Ok Google, turn on my water heater."

5. Other Button Functions

Button blinking rapidly for 120 seconds: This is when the **SMARTHOME** Tankless Water Heater is in WiFi connection mode. To start or repeat connection mode press the on/off button for 10 seconds.

6. Voice Commands

- Alexa/Hey Google, turn <device name> ON/OFF
- Alexa/Hey Google, turn <device name> temperature to <#temp>
- Alexa/Hey Google, what is my current turn <device name> temperature?
- Alexa/Hey Google, set <device name> temperature to <Low, Comfort, High, Commercial>
- Alexa/Hey Google, change <device name> to Celcius/Fahrenheit
- Alexa/Hey Google, turn <device name> Ecco Mode ON/OFF

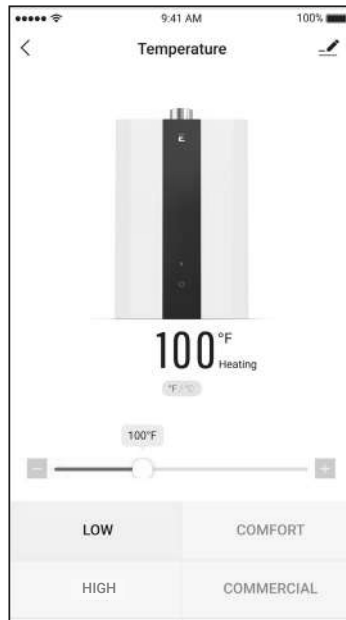

- Current Temperature
- Unit of Measure Toggle (Degrees)
- Temperature Slider
- Quick Set Buttons



- Current Monthly Cost
- Visual History of Cost
- Yearly Breakdown
- Monthly Breakdown (Select month for daily breakdown)

PLEASE NOTE: SH12-A IS FOR INDOOR PERMANENT INSTALLATIONS ONLY. THIS MANUAL AND ALL ECCOTEMP CONTENT IS SUBJECT TO CHANGE WITHOUT NOTICE. PLEASE VISIT SUPPORT.ECCOTEMP.COM FOR MORE INFORMATION.

OPERATING INSTRUCTIONS

HOUSEKEEPING

⚠ DANGER: Before manually operating the relief valve, make certain no one will be exposed to the danger of the hot water released by the valve. The water may be hot enough to create a scald hazard. The water should be released into a suitable drain to prevent injury or property damage.

⚠ DANGER: Hotter water increases the potential for hot water scalds.

⚠ DANGER: Failure to perform the recommended routine preventative maintenance can harm the proper operation of this water heater, which can cause carbon monoxide dangers, excessive hot water temperatures and other potentially hazardous conditions.

⚠ NOTICE: If the pressure relief valve on the hot water heater discharges periodically, this may be due to a problem in the water system. Contact the water supplier or your plumbing contractor on how to correct this. **DO NOT** plug the relief valve outlet.

⚠ NOTICE: After inspection, maintenance, and/ or cleaning, ensure proper operation by turning on a hot water faucet.

Before performing any housekeeping tasks to this water heater, be sure to turn the water heater off and disconnect the power supply.

Vacuum around the water heater for dust, dirt and lint on a regular basis. Clean the water heater and remote control by using a damp soft cloth with a few drops of mild detergent and gently wipe the surfaces. Wipe any remaining moisture with a dry soft cloth.

To ensure sufficient ventilation and combustion air supply, proper clearances must be maintained. The water filters should be cleaned on a monthly basis. Combustion system is fan-assisted.

CLEANING THE WATER HEATER:

- Make sure the water heater is **OFF** and the electrical power supply has been disconnected.
- **DO NOT** scrub the appliance with a brush.
- Use only mild soapy water, other cleaners may damage the surface of the water heater.
- **DO NOT** remove any label including the rating plate while cleaning or servicing.

⚠ DANGER: Shock Hazard. Make sure the electrical power to the water heater is off to avoid potential serious injury or damage to components.

⚠ DANGER: Combustible materials, such as clothing, cleaning materials, or flammable liquids, etc, must not be placed against or next to the water heater.

Properly maintained, your water heater will provide years of dependable trouble-free service. It is recommended that a periodic inspection of the burner, relief valve, water filter and venting system should be made by service personnel qualified in gas appliance repair.

It is suggested that a routine preventive maintenance program be established and followed by the user.

At least once a year, lift and release the lever handle on the pressure relief valve, located in the hot outlet piping of the water heater, to make certain the valve operates freely. Allow several gallons to flush through the discharge line to an open drain.

Rapid closing of faucets or solenoid valves in automatic water using appliances can cause a banging noise heard in a water pipe. Strategically located risers in the water pipe system or water hammer arresting devices can be used to minimize the problem.

Inspect the area around the water heater to ensure a safe operating environment. Keep water heater area clear and free from combustible materials, gasoline, and other flammable vapors and liquids. Ensure the water heater has not been damaged. If damage or denting is present, contact a service personnel to verify proper operation.

Check for any abnormal sounds during normal operation of the water heater.

All piping should be checked for gas and/or water leaks. Refer to page 14 of this manual for instructions on leak testing.

The air intake and cold water supply filters should be cleaned monthly. Refer to the "Housekeeping" section for further information.

DO NOT operate the water heater if you feel something is wrong with it.

DO NOT allow children to operate or otherwise handle the water heater.

OPERATING INSTRUCTIONS

HOUSEKEEPING CONT.

HOW TO CLEAN THE WATER FILTER:

1. Make sure the water heater is **OFF** and the electrical power supply has been disconnected.
2. Turn the water supply **OFF** to the heater.
3. Unscrew the water filter, and slide the filter out.
4. **DO NOT** tap the filter as it may deform and/or damage the filter.
5. **DO** remove severe dust, use a soft brush and wash with running water.
6. Return the filter to the water heater and screw in the filter.
7. Turn the electrical power supply and cold water supply **ON** to the water heater. Repeat the above procedures.

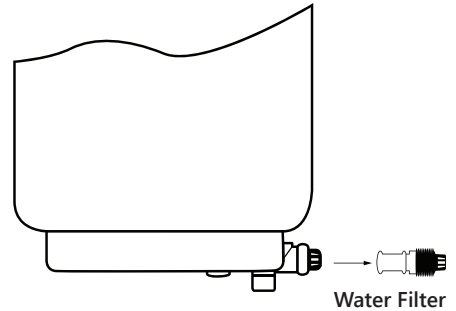

VACATION AND EXTENDED SHUT-DOWN

If the water heater is to remain idle for an extended period of time, the power and water to the appliance should be turned off. If there is no power to the water heater, freeze protection does NOT work.

The water heater and piping should be drained if they might be subjected to freezing temperatures. When freezing temps persists consult with a license installation professional for winterization of your product.

During power outages built in freeze protection will not be activated. Take proper steps to ensure your water heater doesn't freeze.

After a long shut-down period, the water heater's operation and controls should be checked by a qualified service personnel.

ANTI-FREEZING

While the Anti-Freezers will help to protect from cold temperatures, they will in no way guarantee protection from freeze damage. DO NOT rely on the Anti-Freezers to fully protect the water heater from freezing, take all precautions to prevent cold damage.

⚠ NOTICE! The anti-freezing device works for the water heater only, and not for the inlet and outlet water pipes.

***Freezing anywhere in the plumbing system can result in damage to the water heater, such as a rupture in your Heat Exchanger. All pipes must be adequately protected from freezing.**

Water heaters with Anti-Freezers have an automatic heating device and will help to avoid freeze damage, but the power must be kept on. Freezing will occur with no power. In very cold areas and when the temperature is under 32°F, or in event of an ice storm, freezing will occur as the heating power limit is exceeded. If these conditions take place, please follow the procedures explained below.

When the temperature falls below 32°F, water in your plumbing system or water heater can turn to ice and then expand causing damage to the water heater. This damage is not covered under your manufacturer's warranty. If these conditions are anticipated, please drain the water heater as follows to help but not guarantee from freezing:

1. Shut off the main gas valve and power
2. Shut off the inlet water valve
3. Open all faucets
4. Take off the drain valve, and allow water to drain for 3 minutes or until the water heater is empty.
5. Making sure all water is out, replace the drain valve, and shut off the faucets.

⚠ NOTICE! When freezing temperatures persist consult with a licensed installation professional for winterization of your product.

⚠ NOTICE! Eccotemp also recommends adding a backflow preventer to keep freezing outside air from reaching the water heater. Consult with an installation professional for proper installation.

⚠ NOTICE! During power outages built in freeze protection will not be activated. Take proper steps to ensure your water heater doesn't freeze.

PLEASE NOTE: SH12-A IS FOR INDOOR PERMANENT INSTALLATIONS ONLY. THIS MANUAL AND ALL ECCOTEMP CONTENT IS SUBJECT TO CHANGE WITHOUT NOTICE. PLEASE VISIT SUPPORT.ECCOTEMP.COM FOR MORE INFORMATION.

MAINTENANCE

DRAINING THE SH12-A

ENGLISH

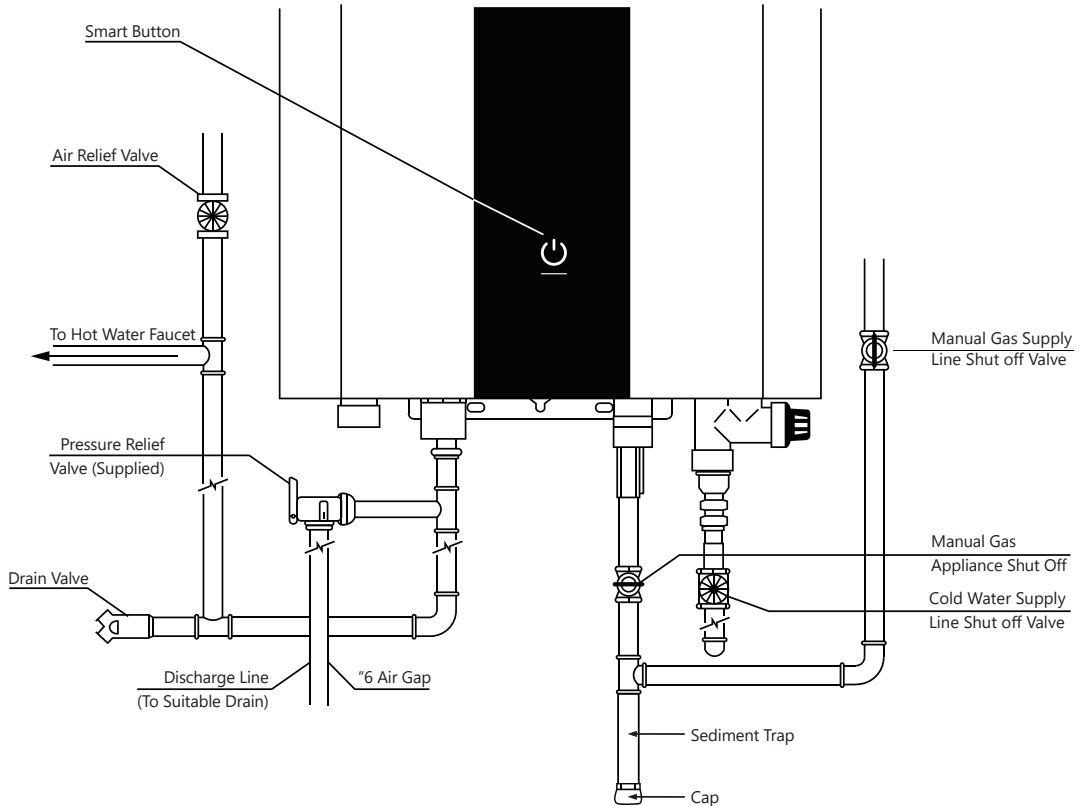

Below are instructions for draining water out of the water heater.

1. Turn off the water heater manually, by using the remote or with the Ecotemp **SMARTHOME** App.
2. Close the gas shut off valve(s).
3. Close the water shut off valve.
4. Turn the on/off switch to the OFF position and disconnect breaker at least 10 seconds after step #1.
5. Open drain valve.
6. Open all hot water faucets. Before proceeding to the next step, make sure that **COLD** water is coming out of all hot water faucets.
7. To put the water heater back into operation after draining, follow the steps below.
8. Reinstall the water filter. Close the hot water outlet drain valve.
9. Open the water shut off valve and close again after making sure that water comes out from hot water faucets. (This step is to remove air from the water lines.)
10. Reconnect the breaker and turn the on/off switch to the **ON** position, fully open the gas shut off valve and the water shut off valve.

⚠ NOTICE: The water heater may not operate unless the above procedure is followed correctly.

PLEASE NOTE: SH12-A IS FOR INDOOR PERMANENT INSTALLATIONS ONLY. THIS MANUAL AND ALL ECCOTEMP CONTENT IS SUBJECT TO CHANGE WITHOUT NOTICE. PLEASE VISIT SUPPORT.ECCOTEMP.COM FOR MORE INFORMATION.

MAINTENANCE

PARTS LIST FOR SH12-A

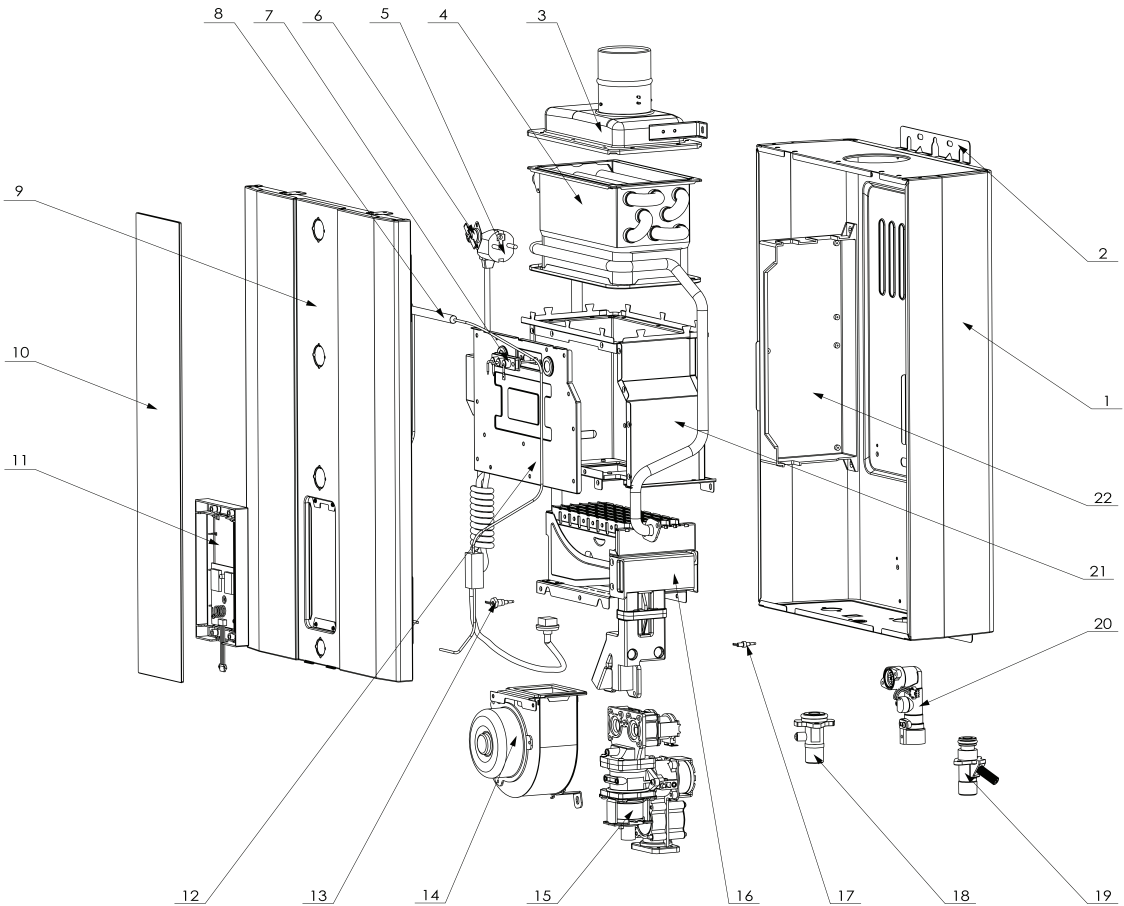

1	Rear Panel	12	Combustion Chamber Cover
2	Panel Hanging Bracket	13	Outlet Water Temp. Sensor
3	Chimney	14	Motor Vent Assembly
4	Heat Exchanger	15	Gas Valve
5	Power Cord	16	Burner Assembly
6	Thermostat	17	Inlet Water Sensor
7	Ignition Sensor Pin	18	Gas Inlet Connector
8	Anti-Freeze Device	19	Water Inlet Connector
9	Front Panel	20	Flow Sensor Assembly
10	Glass	21	Combustion Chamber
11	Display Cover	22	PCB Box

PLEASE NOTE: SH12-A IS FOR INDOOR PERMANENT INSTALLATIONS ONLY. THIS MANUAL AND ALL ECCOTEMP CONTENT IS SUBJECT TO CHANGE WITHOUT NOTICE. PLEASE VISIT SUPPORT.ECCOTEMP.COM FOR MORE INFORMATION.

TROUBLESHOOTING

BEFORE YOU CALL

Save time and money! Review the charts on the following pages first and you may not need to call for service.

This water heater incorporates a variety of shut off devices that prevents the operation of the water heater down if undesirable combustion conditions occur. Such as the presence of a blockage of the combustion air vent insufficient gas or pressure which can impact the safe operation of the water heater. Please contact a qualified service technician if this occurs.

Problem	Possible Cause	What to do
Not hot enough or no hot water.	Water shut-off valve is not fully opened.	Check shut-off valve and open fully.
	Hot water faucet is not fully opened.	Open hot water faucet completely. (The main burner goes off when incoming water volume is inadequate.)
	Water piping is frozen.	Allow piping to thaw.
	No electricity or water supply is cut off.	Check that proper power is being supplied and/or water supply is adequate.
	Water heater is not "ON".	Turn the water heater "ON" by the button on the remote control.
	The temperature may be set too low.	Increase the temperature setting.
	Mixing Valve malfunction (if applicable).	Check and replace if necessary.
	Error code displayed on remote control panel.	See instructions for Error Code and if required, contact a dealer for service.
Water not hot enough.	The temperature may be set too low.	Increase the temperature setting.
	The gas valve is not fully opened.	Check and open the gas valve fully.
Water too hot.	The temperature is set too opened.	Decrease the temperature setting.
	Water shut-off valve is not fully opened.	Check the shut-off valve and open fully.
	Small amount of water has been heated.	Allow more water to flow.
	Water filter is clogged.	Clean the filter with a tooth brush.
Fan continues to rotate after hot water faucet is closed.	This function is to purge unburned gas 10-15 seconds.	Normal operation. There is no need to call for service. Check for error code.

PLEASE NOTE: SH12-A IS FOR INDOOR PERMANENT INSTALLATIONS ONLY. THIS MANUAL AND ALL ECCOTEMP CONTENT IS SUBJECT TO CHANGE WITHOUT NOTICE. PLEASE VISIT SUPPORT.ECCOTEMP.COM FOR MORE INFORMATION.

TROUBLESHOOTING

ERROR CODES

When an error code is displayed:

- Close the hot water faucet, turn off the switch on the remote control.
- Wait for about 5 minutes before turning the switch on again.
- Open the hot water faucet.

▲ NOTICE! If an error code other than those listed below is displayed, immediately turn off the hot water faucet, take note of the error code, turn off the switch on the remote control and call the customer assistance number.

If the error code remains shown:

- Close the hot water faucet and turn off the water heater with the remote control or through the Ecotemp **SMARTHOME** App.
- Take the proper action shown below and attempt operation of the water heater again.
- Turn off the water faucet and turn off the water heater with the remote control or through the Ecotemp **SMARTHOME** App.
- Take note of the error code displayed and call the customer service assistance number in the "If You Need Service".

Error Code	Error Description	Blink Pattern	Possible Cause	What To Do
E1	Outlet Temperature Sensor	BLUE light blinks 1 time, pauses for 2 seconds, then repeats.	Junction port loose, Short circuit.	Call for Service.
E2	Ignition Flame Failure	BLUE light blinks 2 times, pauses for 2 seconds, then repeats.	The gas valve is not opened or fully opened, Water shut-off valve is not open, Junction port loose.	Check and open gas fully, Check and open water valve, Call for service.
E3	Thermostat Sensor	BLUE light blinks 3 times, pauses for 2 seconds, then repeats.	There is flame, but no water is coming in.	Check & open water valve fully, Call for service.
E4	Over Heating Protection	BLUE light blinks 4 times, pauses 2 seconds, then repeats.	Over temperature sensor shuts the water heater off. Outlet water temperature sensor detects the outlet water temperature is over the limit and sends a signal to the main controller to shut off the water heater.	Lower the outlet water temperature, Call for service.
E5	Inlet Temperature Sensor Failure	BLUE light blinks 5 times, pauses 2 seconds, then repeats.	Problem with sensor, problem with sensor's plug or socket, none of the above.	Replace the sensor, fix it, replace the computer board.
E6	Fan Motor Voltage Error	BLUE light blinks 6 time, pauses for 2 seconds, then repeats.	Motor problem, voltage of power supply is too low.	Call for Service.
E7	Solenoid Valve Error	BLUE light blinks 7 time, pauses for 2 seconds, then repeats.	Open circuit of the valve, short circuit of the valve, none of the above.	Connect the valve, replace the valve, replace the computer board.
E8	Vent Pipe Block	BLUE light blinks 8 time, pauses for 2 seconds, then repeats.	Open circuit of the valve, Short circuit of the valve, None of the above.	Clean the pipe.

▲ CAUTION! For your safety DO NOT attempt repair of gas piping, remote control, burners, vent connectors or other safety devices. Refer repairs to qualified service personnel.

▲ CAUTION! Make certain power to water heater is "OFF" before removing protective cover FOR ANY REASON.

▲ CAUTION! Label all wires prior to disconnection when servicing controls. Wiring errors can cause improper and dangerous operation. VERIFY PROPER OPERATION AFTER SERVICING.

PLEASE NOTE: SH12-A IS FOR INDOOR PERMANENT INSTALLATIONS ONLY. THIS MANUAL AND ALL ECOTEMP CONTENT IS SUBJECT TO CHANGE WITHOUT NOTICE. PLEASE VISIT SUPPORT.ECOTEMP.COM FOR MORE INFORMATION.

Eccotemp Systems, LLC

Limited Warranty Information

MODEL(S): SH12-A: LP/NG SMART HOME TANKLESS WHOLE HOME WATER HEATER

I. LIMITED WARRANTY

Subject to the terms below, Eccotemp Systems, LLC ("Eccotemp") provides this limited warranty (the "Limited Warranty") to cover the following Products and Covered Components:

PRODUCT NAME	COVERED COMPONENTS
SH12-A: LP/NG Smart Home Tankless Whole Home Water Heater	SH12-A: LP/NG Smart Home Tankless Whole Home Water Heater: fittings, accessories, and mounting hardware

This Limited Warranty is being provided to the original purchaser and subsequent owners (the "Owner"), but only while the Product remains as the site of the original installation.

II. LIMITED WARRANTY PERIOD

The term of this Limited Warranty (the "Warranty Period") begins on the date of purchase and ends as set forth below:

2 YEAR WARRANTY

The covered components, except for the Heat Element, in the Product are warranted by Eccotemp for a period of two (2) years from the date of purchase when installed according to Eccotemp's Installation and Operating Instructions.

3 YEAR WARRANTY

The Heat Element in the Product is warranted by Eccotemp for a period of three (3) years from the date of purchase when installed according to Eccotemp's Installation and Operating Instructions.

30 DAY WARRANTY

All accessories that have been provided with the Product at no cost are warranted by Eccotemp for a period of thirty (30) days from the date of purchase when installed according to Eccotemp's Installation and Operating Instructions.

III. WARRANTY COVERAGE

If, during the Warranty Period, a component in the Product fails because of a manufacturing defect, Eccotemp will repair, replace, or refund the Product to the Owner at Eccotemp's sole discretion and as determined to be appropriate by the Eccotemp Support Team. As set forth in Section IV, the Owner may be responsible for all shipping, freight, and handling charges, as well as all fees and costs associated with the warranty service, including, but not limited to, all labor and other costs involved in diagnostic calls or in removing, repairing, servicing, or replacing any component. Eccotemp's sole responsibility under this Limited Warranty is to repair, replace, or refund the cost of the Product at Eccotemp's sole discretion. In the event that an exact replacement component is no longer available, Eccotemp will, at its option, provide a substitute component that Eccotemp deems suitable for the Product. If the Owner reports a subsequent issue with any covered component in the Product, the Owner may be responsible for retaining the failed component(s) for 90 days after a warranty claim is filed and must surrender the component(s) at the request of Eccotemp.

Both Eccotemp and the Owner of the Product are bound by this Limited Warranty.

IV. MAKING A WARRANTY CLAIM

To make a warranty claim through this Limited Warranty, the Owner must contact Eccotemp's Customer Service team at support@eccotemp.com, schedule a call or live chat on the Eccotemp support page at <http://support.eccotemp.com>. It is within Eccotemp's sole discretion when a repair, replacement, or refund will be issued. Any return for refund must be approved by Eccotemp's Customer Service team prior to shipping the Product back to Eccotemp. Please refer to Returning Your Product For Repair or Refund Policy provided with the Product.

Within the first 45 days of purchase, Eccotemp will cover all ground shipping costs for warranty related issues in the US and Canada, excluding Alaska, Hawaii and any location outside of the continental US and Canada. After the first 45 days of purchase, the Owner is responsible for all shipping to Eccotemp, regardless of reason or circumstance. Eccotemp will cover the warranty related shipping costs when returning the Product to the Owner after repair/inspection. The method for warranty related shipping will be ground equivalent with the provider within Eccotemp's sole discretion.

What information you will need for processing of your warranty claim:

- Proof of purchase
- Serial number
- Photos of the installation
- Photos of the damage point (if there is one)

All shipments of any type of product coming to Eccotemp for any reason must have a Return Goods Authorization ("RGA") number for any repairs to be made. Please contact Eccotemp to obtain an RGA number prior to shipping anything to Eccotemp. Failure to do so could result in loss of Product. Eccotemp will not be responsible for replacement due to loss or damage if these steps are not properly followed.

Any returns to Eccotemp must be sent in the original packaging. If your returned product does not have the original packaging and/or is missing any of the components that came with the product, there will be a nonnegotiable 15% restock fee.

PLEASE NOTE: SH12-A IS FOR INDOOR PERMANENT INSTALLATIONS ONLY. THIS MANUAL AND ALL ECCOTEMP CONTENT IS SUBJECT TO CHANGE WITHOUT NOTICE. PLEASE VISIT SUPPORT.ECCOTEMP.COM FOR MORE INFORMATION.

Eccotemp Systems, LLC

Limited Warranty Information

MODEL(S): SH12-A: LP/NG SMART HOME TANKLESS WHOLE HOME WATER HEATER

V. DISCLAIMER OF WARRANTIES AND RESPONSIBILITY FOR DAMAGES

EXCEPT AS PROVIDED IN THIS LIMITED WARRANTY, ECCOTEMP MAKES NO WARRANTY, EXPRESS OR IMPLIED, TO ANYONE AS TO FITNESS FOR ANY PURPOSE, MERCHANTABILITY, DESIGN, CONDITION, CAPACITY, PERFORMANCE, OR ANY OTHER ASPECT OF THE PRODUCT OR ITS MATERIAL OR WORKMANSHIP. ALL IMPLIED WARRANTIES WHICH MAY EXIST, NOT WITHSTANDING THIS DISCLAIMER, ARE LIMITED TO THE DURATION OF THIS LIMITED WARRANTY. THIS LIMITED WARRANTY IS MADE IN LIEU OF ALL OTHER GUARANTEES, WARRANTIES, REPRESENTATIONS, CONDITIONS, OBLIGATIONS, OR LIABILITIES, EXPRESS OR IMPLIED.

ECCOTEMP SHALL NOT BE LIABLE, EITHER IN CONTRACT OR TORT, FOR ANY DIRECT, INDIRECT, INCIDENTAL OR CONSEQUENTIAL DAMAGES, OR ANY LOSS, DAMAGE, OR INJURY TO PERSONS, INCLUDING DEATH, PROPERTY, OR THINGS, OR FOR DAMAGES OF ANY KIND OR NATURE INCLUDING BUSINESS INTERRUPTION, INCONVENIENCE OR LOSS OF ANTICIPATED PROFITS OR SAVINGS OCCASIONED BY OR ARISING OUT OF THE USE, MISUSE, NON-USE, REPAIR, REPLACEMENT OR DELAY IN DELIVERY OF THE PRODUCT. ECCOTEMP SHALL NOT BE LIABLE FOR THE COST OF ANY WORK DONE BY PURCHASER OR OTHERS TO THE PRODUCT.

This Limited Warranty gives specific legal rights. Some jurisdictions do not allow the exclusion or limitation of implied warranties or incidental or consequential damages. In such jurisdictions, the limitations or exclusions do not apply to the Owner. The Owner may also have other rights that may vary by jurisdiction.

VI. EXCLUSIONS

The following exclusions apply to this Limited Warranty:

1. A repair, replacement, or refund will not be provided under this Limited Warranty unless the Product containing the defective component is properly installed and maintained according to Eccotemp's Installation Manual and Use & Care Manual and in compliance with all applicable federal, state/province, and local laws, regulations, codes, policies, and licensing requirements. Any abuse, misuse, alteration, neglect, or misapplication of the Product will render this Limited Warranty null and void.
2. A repair, replacement, or refund will not be provided if the Product is damaged by services performed by third party service providers other than Eccotemp Systems.
3. Eccotemp systems is not responsible for any expenses arising from labor services, including but not limited to, installation or removal services due to a warranty claim.
4. A repair, replacement, or refund will not be provided if the Product is used in a hot water circulation loop, in series with a circulation system, where an on-demand recirculation system is incorporated, or in any other corrosive or otherwise destructive environment where the Product is not intended to be used as set forth in Eccotemp's Installation Manual and Use & Care Manual.
5. A repair, replacement, or refund will not be provided if the Product is damaged as a result of improper installation, including improper ventilation materials, sizing, length, elevation, condensation drainage, or inadequate airflow.
6. A repair, replacement, or refund will not be provided if the Product is damaged as a result of improper use, including freezing within the unit or surrounding piping, incorrect sizing for the application, scale build up, or incorrect gas and/or water pressure.
7. This Product shall not be used as a pool or spa heater. Use of the Product as a pool or spa heater shall be considered misuse and will render this Limited Warranty null and void.
8. A repair, replacement, or refund will not be provided if the Product is damaged by the use of non-potable, untreated or poorly treated well water, or water with high PH levels or hardness levels in excess of 12 grains per gallon (200 mg/L).
9. A repair, replacement, or refund will not be provided under this Limited Warranty if the original serial number on the Product has been removed or altered in a way that causes the serial number to not be readily determined.
10. Eccotemp will not pay electricity or fuel costs, or increases in electricity or fuel costs, for any reason whatsoever, including additional or unusual use of supplemental electrical heat.
11. Eccotemp will not be responsible for any default or delay in performance under this Limited Warranty caused by any factor or contingency outside of its control.

VII. MISCELLANEOUS

No agent, employee or representative of Eccotemp has any authority to bind Eccotemp to any representation or warranty concerning the Product not contained in this Limited Warranty. Eccotemp reserves the right and authority to change, modify or alter this warranty at any given time.

VIII. FOR CUSTOMERS WITH A HOME WARRANTY

Often your home warranty will assist in covering some of the fees related to your home appliances, such as your water heater. Be sure to check with your home warranty company for assistance prior to reaching out to Eccotemp.

PLEASE NOTE: SH12-A IS FOR INDOOR PERMANENT INSTALLATIONS ONLY. THIS MANUAL AND ALL ECCOTEMP CONTENT IS SUBJECT TO CHANGE WITHOUT NOTICE. PLEASE VISIT SUPPORT.ECCOTEMP.COM FOR MORE INFORMATION.

Notes

PLEASE NOTE: SH12-A IS FOR INDOOR PERMANENT INSTALLATIONS ONLY. THIS MANUAL AND ALL ECCOTEMP CONTENT IS SUBJECT TO CHANGE WITHOUT NOTICE. PLEASE VISIT [SUPPORT.ECCOTEMP.COM](https://support.eccotemp.com) FOR MORE INFORMATION.



ECCOTEMP[®]

HEATING WATER SMARTER

315-A INDUSTRIAL ROAD, SUMMERVILLE, SC 29483 | 1-866-356-1992

© Eccotemp 2024 All Rights Reserved | Printing Version 1.0