



ESH 2.5 / 4.0

# SMARTHOME

## Mini Tank Water Heater INSTALLATION, USE AND CARE MANUAL



SMART ON/OFF  
BUTTON



SMART VOICE  
COMMANDS



SMARTHOME  
READY

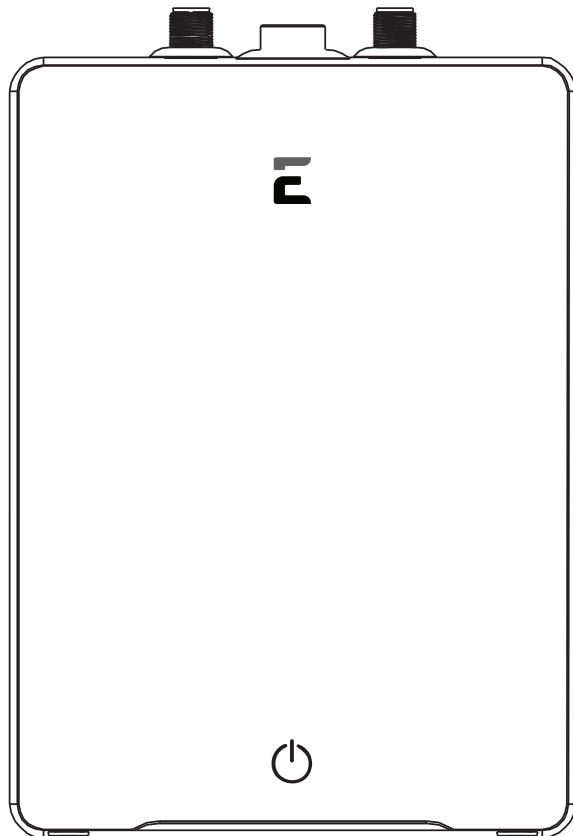

ADVANCED ERROR  
DETECTION



DIGITAL PRECISION  
HEATING



INTELLIGENT  
CONTROL BOARD

## HEATING WATER **SMARTER**

"Alexa,  
turn on my Mini Water Heater."



"Ok Google,  
set my Mini Water Heater to 110°"





315-A Industrial Road  
 Summerville, SC 29483  
 1-866-356-1992  
 support@eccotemp.com



**SMARTHOME MINI TANK WATER HEATER  
 SMARTHOME MINI RESERVOIR CHAUFFE-EAU**

<b>MODEL / le modèle:</b>	<b>ESH-2.5</b>
<b>RATED POWER / Puissance nominale:</b>	<b>1440W</b>
<b>RATED VOLTAGE / Tension Nominale:</b>	<b>120V ~ 60Hz</b>
<b>TANK CAPACITY / Capacité du réservoir:</b>	<b>2.5 gal</b>
<b>MAX RATED PRESSURE / Pression Maximale Nominale:</b>	<b>150 psi</b>

Conforms To UL STD. 174  
 Certified To CSA STD. C22.2 NO. 110

SERIAL NO /  
 Numéro de  
 Série:

**SMARTHOME MINI TANK WATER HEATER  
 SMARTHOME MINI RESERVOIR CHAUFFE-EAU**

<b>MODEL / le modèle:</b>	<b>ESH-4.0</b>
<b>RATED POWER / Puissance nominale:</b>	<b>1440W</b>
<b>RATED VOLTAGE / Tension Nominale:</b>	<b>120V ~ 60Hz</b>
<b>TANK CAPACITY / Capacité du réservoir:</b>	<b>4.0 gal</b>
<b>MAX RATED PRESSURE / Pression Maximale Nominale:</b>	<b>150 psi</b>

Conforms To UL STD. 174  
 Certified To CSA STD. C22.2 NO. 110

SERIAL NO /  
 Numéro de  
 Série:

**⚠ DANGER**

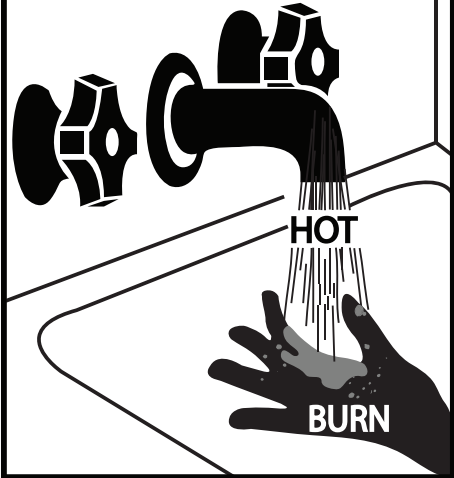

Water temperature over 125 °F (52 °C) can cause severe burns instantly or death scalds. Children, disabled and elderly are at the highest risk of being scalded. See instruction manual before setting temperature at water heater. Feel water before bathing or showering. Temperature limiting values are available, see manual.

PLEASE NOTE: MINI TANKS ARE FOR INDOOR PERMANENT INSTALLATIONS ONLY. BEFORE POWERING THE WATER HEATER, BE SURE THAT THE SYSTEM IS COMPLETELY FILLED WITH WATER AND ALL AIR IS REMOVED. THIS MANUAL AND ALL ECCOTEMP CONTENT IS SUBJECT TO CHANGE WITHOUT NOTICE. PLEASE VISIT SUPPORT.ECCOTEMP.COM FOR MORE INFORMATION.



**⚠ CAUTION!** A damaged power supply cord must be replaced with one supplied by the unit manufacturer and not repaired.

**⚠ CAUTION!** When a supplemental heat source is connected to the Certified Household Electric Storage Tank Water Heater, provisions must be made to limit the heat source temperature not to exceed that of the water heater thermostat setting.

**⚠ CAUTION!** If the water heater has been retrofitted with supplemental heating equipment, you must adjust both the thermostat controlling the supplemental heat source located in the water piping and the thermostat on the water heater behind the access panel to the same temperature. Failure to adjust both thermostats to the same temperature can cause loss of proper temperature control.

**⚠ CAUTION!** To reduce the risk of electric shock or fire, use only on a utility supply having a maximum 125/250 volt, three wire system.

**⚠ CAUTION!** To reduce the risk of electrical shock, connect ground to water heater. For detailed information refer to instructions.

**⚠ CAUTION!** Install temperature and pressure protective equipment required by local codes, but no less than a combination temperature and pressure relief valve certified as meeting the requirements for relief valves, ANSI 21.22, by a nationally recognized testing laboratory that maintains periodic inspection of production of listed equipment or materials. The valve must be oriented, provided with tubing, or otherwise installed so that discharge can exit only within 6 inches above, or at any distance below, the structural floor, and cannot contact any live electrical part.

**⚠ DANGER!** To reduce the risk of electric shock, disconnect from power supply before replacing temperature-limiting device.

**⚠ CAUTION!** To reduce the risk of excessive pressures and temperatures in this water heater, install temperature and pressure protective equipment required by local codes and no less than a combination temperature and pressure relief valve certified by a nationally recognized testing laboratory that maintains periodic inspection of production of listed equipment or materials, as meeting the requirements for Relief Valves and Automatic Gas Shutoff Devices for Hot Water Supply Systems, ANSIZ21.22. This valve must be marked with a maximum set pressure not to exceed the marked maximum working pressure of the water heater. Install the valve into an opening provided and marked for this purpose in the water heater, and orient it or provide tubing so that any discharge from the valve fits only within 6 inches above, or at any distance below, the structural floor, and does not contact any live electrical part. The discharge opening must not be blocked or reduced in size under any circumstances.

PLEASE NOTE: MINI TANKS ARE FOR INDOOR PERMANENT INSTALLATIONS ONLY. BEFORE POWERING THE WATER HEATER, BE SURE THAT THE SYSTEM IS COMPLETELY FILLED WITH WATER AND ALL AIR IS REMOVED. THIS MANUAL AND ALL ECCOTEMP CONTENT IS SUBJECT TO CHANGE WITHOUT NOTICE. PLEASE VISIT [SUPPORT.ECCOTEMP.COM](http://SUPPORT.ECCOTEMP.COM) FOR MORE INFORMATION.

# ECCOTEMP SMARHTHOME MINI TANK WATER HEATER

## Safety Information

Safety Precautions .....4

## General Information

Introduction .....5

## Technical Specifications

Model Specific information .....6

Wiring Diagram .....7

Installation Instructions .....8

Water Connections .....9

Pressure Relief Valve .....10-11

## Getting Started

Filling the Water Heater .....12

Using the Mobile App .....13-14

Setting the Temperature .....15-17

Voice Commands .....18

## Maintenance

Housekeeping .....19

Blow Out Diagram .....20-21

Troubleshooting .....22-23

## Warranty Information

Warranty .....24-25

Product Comparison .....26

## Use & Care Manual

With Installation Instructions for the Installer

APPLICATION

Point Of Use

INSTALLATION

Indoor

CAPACITY

2.5 gal / 4 gal

## CONGRATULATIONS!

You have just purchased a new Eccotemp Mini Tank Water Heater. This will open a world of possibilities where you can enjoy hot water!

We highly suggest you take the time to read through all of the safety and installation procedures in this manual before attempting to install your new Mini Tank Water Heater.

Should you have any questions, please feel free to visit our help-desk located at: [support.eccotemp.com](http://support.eccotemp.com)

— PLEASE RETAIN THE INSTRUCTION MANUAL FOR FUTURE REFERENCE —

## FOR YOUR RECORDS

Write your serial number here: # \_\_\_\_\_

You can find them on a label on the appliance and/or packaging. Staple sales slip or canceled check here. Proof of the original purchase date is needed to obtain service under the warranty.

## READ THIS MANUAL

Inside you will find many helpful hints on how to use and maintain your water heater properly. A little preventive care on your part can save you time and money over the life of your water heater. You will find many answers to common problems in the Troubleshooting Guide. If you review the chart of Troubleshooting Tips first, you may not need to call for service.

## READ THE SAFETY INFORMATION

Your safety and the safety of others are very important. There are many important safety messages in this manual and on your water heater. Always read and obey all safety messages. This is the safety alert symbol. Recognize this symbol as an indication of Important Safety Information! This symbol alerts you to potential hazards that can kill or hurt you and others.

All safety messages will follow the safety alert symbol and the words: **“DANGER”**, **“WARNING”**, **“CAUTION”** or **“NOTICE”**. These words mean:

**⚠ WARNING! A potentially hazardous situation that could result in death or serious injury and/or damage to property.**

**⚠ DANGER! An imminently hazardous situation that will result in death or serious injury.**

**⚠ CAUTION! A potentially hazardous situation that may result in minor or moderate injury.**

**⚠ NOTICE! Attention is called to observe a specified procedure or maintain a specific condition.**

PLEASE NOTE: MINI TANKS ARE FOR INDOOR PERMANENT INSTALLATIONS ONLY. BEFORE POWERING THE WATER HEATER, BE SURE THAT THE SYSTEM IS COMPLETELY FILLED WITH WATER AND ALL AIR IS REMOVED. THIS MANUAL AND ALL ECCOTEMP CONTENT IS SUBJECT TO CHANGE WITHOUT NOTICE. PLEASE VISIT [SUPPORT.ECCOTEMP.COM](http://SUPPORT.ECCOTEMP.COM) FOR MORE INFORMATION.

## IMPORTANT SAFETY INSTRUCTIONS

---

**⚠ WARNING!** When using electrical appliances, safety precautions to reduce the risk of fire, electric shock or injury to persons should be followed, including:

1. READ ALL INSTRUCTIONS BEFORE USING THIS WATER HEATER.
2. This water heater must be grounded. Connect only to properly grounded outlet. See POWERING THE WATER HEATER found on page 13.
3. Install or locate this water heater only in accordance with the provided installation instructions.
4. Use this water heater only for its intended use as described in this manual.
5. Do not use an extension cord with this water heater. If power is not available adjacent to the water heater, contact a qualified electrician to have a receptacle properly installed.
6. As with any appliance, close supervision is necessary when used by children.
7. Do not operate this water heater if it has a damaged cord or plug, if it is not working properly, or if it has been damaged or dropped.
8. Only qualified service personnel should service this water heater. Contact nearest authorized service facility when questions arise or service is required.
9. Do not use surge protectors or multi-outlet adapters with this water heater.

## SAVE THESE INSTRUCTIONS

The manufacturer and/or distributor is not responsible for damages caused by improper installation, or failure to follow the instructions in this manual.

A QUALIFIED, LICENSED TECHNICIAN IS RECOMMENDED TO INSTALL THE WATER HEATER AND CONDUCT ALL SUBSEQUENT SERVICE WORK AND/OR MAINTENANCE.

## IMPORTANT!

FILL THE TANK COMPLETELY FULL WITH WATER AND HAVE WATER FLOWING FROM THE HOT WATER FAUCET BEFORE ACTIVATING POWER TO THE HEATER FOR THE FIRST TIME OR DAMAGE WILL RESULT.

## ⚠ CAUTION!

Hydrogen gas can be produced in a hot water system served by this heater that has not been used for a long period of time (generally 2 weeks or more). Hydrogen gas is extremely flammable. To reduce the risk of injury under these conditions, it is recommended that the hot water faucet be opened for several minutes at the nearest and most distant sink being served by this water heater before using any electrical appliance connected to the hot water system (i.e. Dishwasher). If hydrogen gas is present, there will probably be an unusual sound such as air escaping through the faucet as the water begins to flow. There should be no smoking or open flame near the faucet at this time.

PLEASE NOTE: MINI TANKS ARE FOR INDOOR PERMANENT INSTALLATIONS ONLY. BEFORE POWERING THE WATER HEATER, BE SURE THAT THE SYSTEM IS COMPLETELY FILLED WITH WATER AND ALL AIR IS REMOVED. THIS MANUAL AND ALL ECCOTEMP CONTENT IS SUBJECT TO CHANGE WITHOUT NOTICE. PLEASE VISIT [SUPPORT.ECCOTEMP.COM](http://SUPPORT.ECCOTEMP.COM) FOR MORE INFORMATION.

# General Information

The Eccotemp **SMARTHOME** Mini Tank Water Heater can be used in most boats, campers, tiny homes, RV's, homes, under the sink, offices, cottages, kitchens, utility rooms, apartments, and food trucks. Eccotemp **SMARTHOME** Mini Tank models are designed to supply hot water for all hand wash and kitchen sinks in a residential environment.

Eccotemp **SMARTHOME** Mini Tank models can replace traditional central hot water heaters, thereby conserving water and reducing energy waste.

The Eccotemp **SMARTHOME** Mini Tank Water Heaters are lightweight, compact, and manufactured for easy installation. Eccotemp **SMARTHOME** Mini Tank models can be mounted on the wall with included hardware, or they can be placed freestanding.

Eccotemp **SMARTHOME** Mini Tank models are designed to operate at 150-psi maximum water pressure. Install a pressure-reducing valve if your water pressure is greater than 150-psi.

Eccotemp **SMARTHOME** Mini Tank Water Heaters also come with an app for your mobile device that can be downloaded from the Apple App Store and the Google Play Store. Search for "Eccotemp" to easily find the app, download it, install it, and begin using the app to complete your setup. Once you have the app set up, you can use it to adjust the temperature through your smart phone, or **SMARTHOME** devices, to increase the energy efficiency of your home.

**⚠ CAUTION! The manufacturer cannot be responsible for the damage caused by improper installation or by failure to follow instructions in this manual. Comply with the Installation Instructions before connecting to electrical outlet.**

**⚠ CAUTION! The thermostat has been pre-set at the factory to 125°F (51.7°C) or lower to reduce the risk of scalding injuries.**

**⚠ WARNING! Installer should review the contents of this manual with the owner upon completion of the installation, and the manual should remain with the owner and placed in a location close to the water heater.**

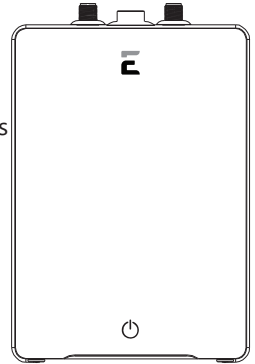

## Technical Specifications

### Models: Eccotemp SMARTHOME Mini Tank ESH 2.5 and ESH 4.0

There are currently two Eccotemp **SMARTHOME** Mini Tank models, a 2.5-gallon and 4-gallon. The pressure vessel (water tank) is welded, glass-lined steel and is equipped with an anode rod.

The water heater is equipped with a thermostat and a high limit temperature switch that can be controlled by the Eccotemp **SMARTHOME** app or by the manual controls. Also, a pressure relief valve is supplied with your water heater.

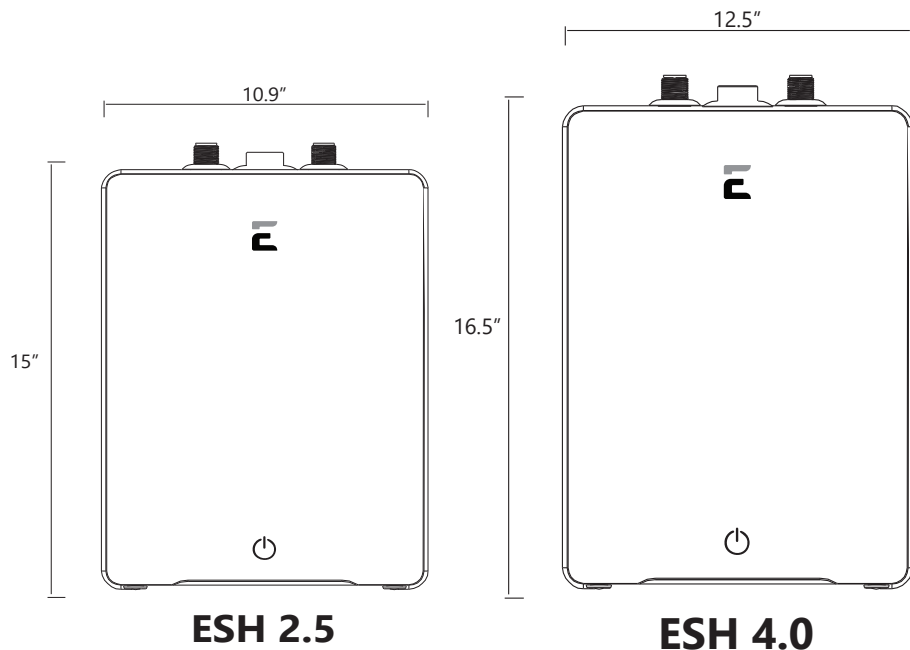

**⚠ NOTICE!** To use wifi settings you must ensure the manual temperature control knob is in wifi mode.

### INCLUDED ACCESSORIES

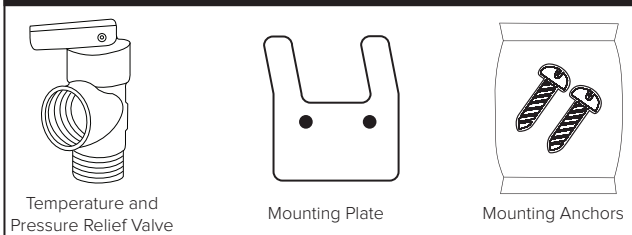

PLEASE NOTE: MINI TANKS ARE FOR INDOOR PERMANENT INSTALLATIONS ONLY. BEFORE POWERING THE WATER HEATER, BE SURE THAT THE SYSTEM IS COMPLETELY FILLED WITH WATER AND ALL AIR IS REMOVED. THIS MANUAL AND ALL ECCOTEMP CONTENT IS SUBJECT TO CHANGE WITHOUT NOTICE. PLEASE VISIT [SUPPORT.ECCOTEMP.COM](http://SUPPORT.ECCOTEMP.COM) FOR MORE INFORMATION.

# Technical Specifications

## Wiring Diagram

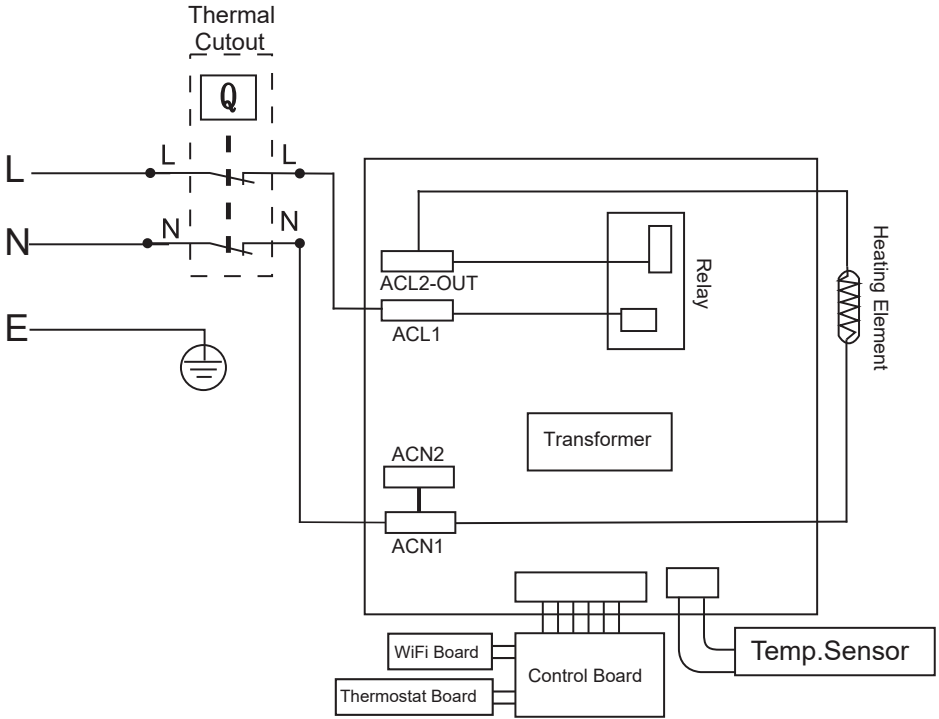

## Electrical, Pressure and Recovery Specifications

Technical Data			
MODEL	Unit	ESH-2.5	ESH-4.0
Capacity	Gallons	2.5	4.0
Voltage	VAC	110-120	110-120
Power @ 120 VAC	Watts	1440	1440
Max. Water Pressure	Psi	150	150
Weight (empty)	Lbs.	20	25
Amperage	Amps	12	12
Phases		1	1

PLEASE NOTE: MINI TANKS ARE FOR INDOOR PERMANENT INSTALLATIONS ONLY. BEFORE POWERING THE WATER HEATER, BE SURE THAT THE SYSTEM IS COMPLETELY FILLED WITH WATER AND ALL AIR IS REMOVED. THIS MANUAL AND ALL ECCOTEMP CONTENT IS SUBJECT TO CHANGE WITHOUT NOTICE. PLEASE VISIT SUPPORT.ECCOTEMP.COM FOR MORE INFORMATION.



# Installation Instructions

A licensed professional should complete the installation adhering to all state and local codes. The manufacturer will not be liable for any damages because of failure to comply with these installation instructions or because of improper installation performed by an unqualified installer.

## CHOOSE A LOCATION

Select a location that allows ease of access for maintenance, ideally with at least 9 inches of clearance at the top from any ceiling or cabinet interior.

**Note:** Only install in a vertical position.

### Free Standing

Sit on the floor under a sink or in a cabinet, upright, as pictured in the diagram below and on the front cover of this manual.

**Note:** Make sure to leave at least nine (9) inches of clearance above your water heater.

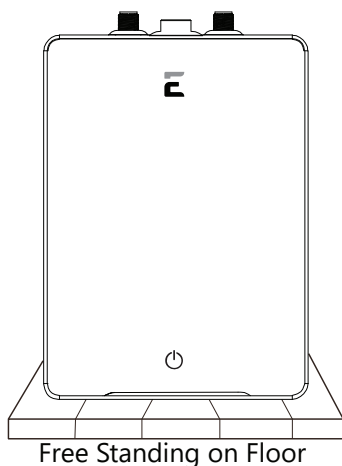

### Wall Mounted

Fasten the supplied mounting bracket to the wall. Use screws that are suitable for the wall material and the weight of the water heater filled to capacity (ESH-2.5-41 lbs.; ESH-4.0-57 lbs.). Hang the water heater on the bracket and pull downwards on the water heater to ensure that both fingers of the bracket are seated in the mounting slots.

**Note:** Confirm your water piping orientation (hot and cold) before wall mounting.

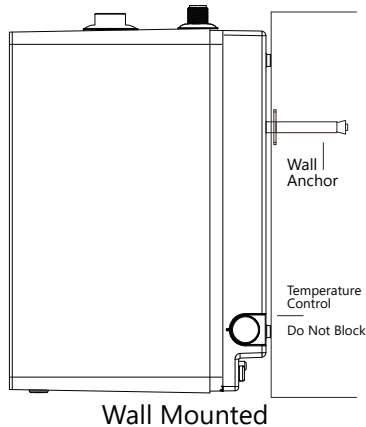

PLEASE NOTE: MINI TANKS ARE FOR INDOOR PERMANENT INSTALLATIONS ONLY. BEFORE POWERING THE WATER HEATER, BE SURE THAT THE SYSTEM IS COMPLETELY FILLED WITH WATER AND ALL AIR IS REMOVED. THIS MANUAL AND ALL ECCOTEMP CONTENT IS SUBJECT TO CHANGE WITHOUT NOTICE. PLEASE VISIT [SUPPORT.ECCOTEMP.COM](http://SUPPORT.ECCOTEMP.COM) FOR MORE INFORMATION.

# Installation Instructions

## WATER CONNECTIONS

Water connections should be in close orientation to the install site. Confirm there is enough allowance for the water intake and outtake hoses to reach the water heater.

**Note:** If your water pipes are copper or bronze be sure to use dielectric connections to prevent corrosion. Failure to do so may cause damage to your tank and void your warranty. In order to protect the water heater from heat damage due to soldering, solder a piece of tubing to a threaded union fitting before screwing the union to the tank.

1. Install a shut off valve in line with the cold-water pipe.
2. Connect the cold water pipe to the inlet nipple, marked with a blue ring.
3. Connect the hot water pipe to the outlet nipple, marked with a red ring.

**⚠ NOTICE: Do not attempt to remove rubber washer.**

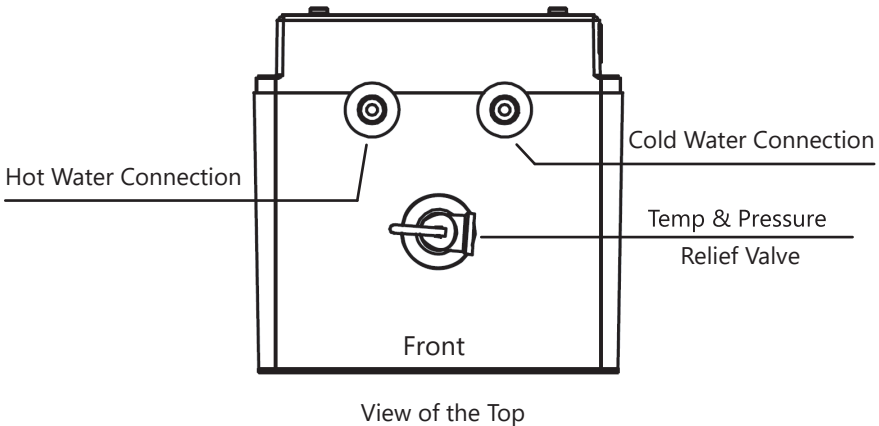

**IMPORTANT:** Failure to provide dielectric insulation may result in premature tank or nipple failure and may void your warranty. The Temperature & Pressure Relief valve (T&P valve) is for servicing and the valve should be in the open position when the water heater is in operation. **DO NOT APPLY HEAT DIRECTLY TO INLET OR OUTLET CONNECTIONS.**

PLEASE NOTE: MINI TANKS ARE FOR INDOOR PERMANENT INSTALLATIONS ONLY. BEFORE POWERING THE WATER HEATER, BE SURE THAT THE SYSTEM IS COMPLETELY FILLED WITH WATER AND ALL AIR IS REMOVED. THIS MANUAL AND ALL ECCOTEMP CONTENT IS SUBJECT TO CHANGE WITHOUT NOTICE. PLEASE VISIT SUPPORT.ECCOTEMP.COM FOR MORE INFORMATION.

# Installation Instructions

## TEMPERATURE & PRESSURE RELIEF VALVE

CLOSED SYSTEM THERMAL EXPANSION: Periodic discharge of the relief valve or failure of the element gasket may be due to thermal expansion in a closed water supply system. The water utility supply meter may contain a check valve, backflow preventer or water pressure-reducing valve that will create a closed water system. During the heating cycle of the water heater, the heated water expands causing pressure inside the water heater to increase. The T&P relief valve may discharge hot water under these conditions that result in a loss of energy and a build up of lime on the relief valve seat. To prevent this from happening, there are two recommendations:

1. Install a diaphragm-type domestic hot water expansion tank (suitable for potable water) on the cold water supply line. The expansion tank must have a minimum capacity of 1.5 U.S. gallons for every 50 gallons of stored water.
2. Install a 125-PSI pressure relief valve in the cold water supply line. Make sure the discharge of this valve is directed to an open drain and protected from freezing.

Included with your water heater is a temperature and pressure relief (T&P valve) valve that is certified by a nationally recognized laboratory. This is designed to reduce the risk of excessive pressures and temperatures in this water heater and should be installed as directed by local codes. The T&P valve is marked with a maximum pressure, which does not exceed the maximum working pressure of the water heater (150 psi).

**Note:** If using a different temperature and pressure relief valve other than the one provided with your purchase, please ensure that the maximum PSI marking on the valve DOES NOT exceed the marked maximum working pressure of the water heater.

1. Install the T&P valve supplied with the water heater into the threaded opening at the top of the water heater.
2. Attach a discharge pipe from the T&P valve terminating at a sink or drain. Do not cap or plug the end of the discharge pipe.

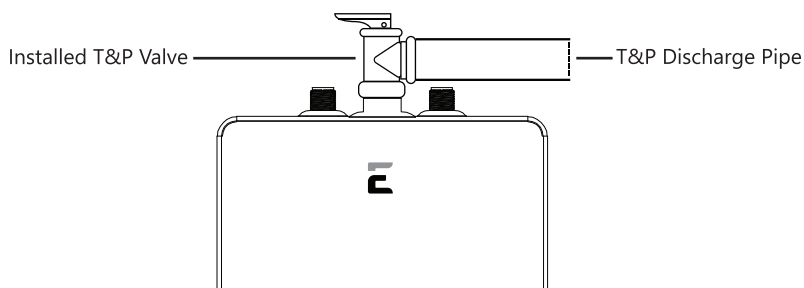

PLEASE NOTE: MINI TANKS ARE FOR INDOOR PERMANENT INSTALLATIONS ONLY. BEFORE POWERING THE WATER HEATER, BE SURE THAT THE SYSTEM IS COMPLETELY FILLED WITH WATER AND ALL AIR IS REMOVED. THIS MANUAL AND ALL ECCOTEMP CONTENT IS SUBJECT TO CHANGE WITHOUT NOTICE. PLEASE VISIT [SUPPORT.ECCOTEMP.COM](http://SUPPORT.ECCOTEMP.COM) FOR MORE INFORMATION.

# Installation Instructions

## TEMPERATURE & PRESSURE RELIEF VALVE

A discharge line should be installed and exit only 6 inches above, or at any distance below, and should not come in contact with any live electrical part. The T&P discharge opening must not be blocked or reduced in size under any circumstances.

**IMPORTANT: Failure to provide dielectric insulation may result in premature tank or nipple failure and may void your warranty. The T&P valve is for servicing and the valve should be in the open position when the water heater is in operation. DO NOT APPLY HEAT DIRECTLY TO INLET OR OUTLET CONNECTIONS.**

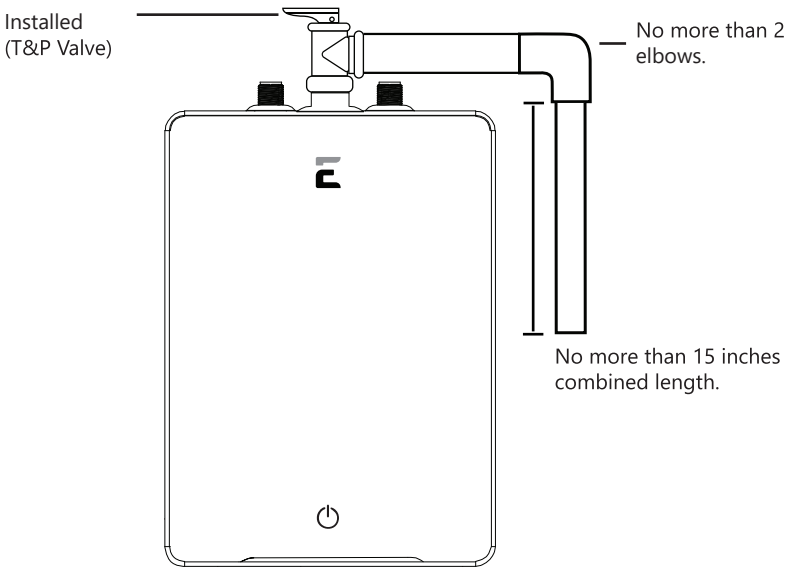

### Installing the T&P Valve Discharge Pipe:

1. Must NOT be smaller in diameter than the outlet diameter of the valve, or have any reducing couplings.
2. Must NOT be plugged or blocked.
3. Must be made of suitable material for hot water.
4. Must not be over 15 inches in length.
5. Must not have more than two elbows.
6. Must terminate at an adequate drain.
7. Must not have a shut off valve between relief valve and tank or relief valve and termination of discharge.

PLEASE NOTE: MINI TANKS ARE FOR INDOOR PERMANENT INSTALLATIONS ONLY. BEFORE POWERING THE WATER HEATER, BE SURE THAT THE SYSTEM IS COMPLETELY FILLED WITH WATER AND ALL AIR IS REMOVED. THIS MANUAL AND ALL ECCOTEMP CONTENT IS SUBJECT TO CHANGE WITHOUT NOTICE. PLEASE VISIT [SUPPORT.ECCOTEMP.COM](http://SUPPORT.ECCOTEMP.COM) FOR MORE INFORMATION.

# Getting Started

## FILLING THE WATER HEATER

Before connecting the power, fill the tank and system with water and check for leaks. To be sure that all remaining air is out of the water system, open the hot water faucets on your fixtures until constant water flows. Any air remaining in the tank will cause the water heater element to fail.

1. Open the hot water faucet.
2. Open the cold water supply valve.
3. When continuous water flows out of the faucet, the tank is filled.
4. Close the hot water faucet.
5. Check entire system for leaks.

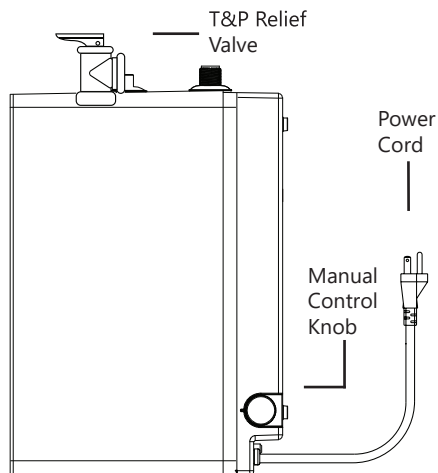

## POWERING THE WATER HEATER

**⚠ CAUTION! Before powering the water heater, be sure that the system is completely filled with water and ALL AIR IS REMOVED.**

To be certain that all of the air is out of the water heater, open the HOT water faucet on the fixtures until constant water flows from them. If air remains in the tank, the element will be damaged when the electric cord is plugged in.

The Eccotemp **SMARTHOME** Mini Tank water heater comes equipped with a power cord that is intended to plug into a standard 110/120v receptacle. Adhere to all pertinent state and local codes. The Eccotemp **SMARTHOME** Mini Tank was manufactured and wired in accordance with ETL requirements.

Powering Your Eccotemp **SMARTHOME** Water Heater:

1. Plug your Mini Tank to a grounded outlet.
2. Adjust the temperature of the water heater either by the manual temperature controls or the **SMARTHOME** app. Manual temperature controls are located towards the back on the right side.
3. Allow up to 25 minutes to achieve desired set temperature.

The Eccotemp **SMARTHOME** Mini Tank Water Heater comes equipped with an overheat sensor with a manual reset; also known as the temperature high limit. This device has been factory installed to interrupt the power supply in the event of a thermostat failure. The manual reset is located on the back of the mini in the middle at the bottom. If you have wall mounted your water heater, you may need to unmount it to reach the reset switch.

**WARNING! This water heater is designed for 110/120v service - DO NOT CONNECT TO ANY OTHER VOLTAGE. Failure to use proper voltage may result in personal injury and/or property damage. If the supplied electrical power cord is either damaged or not long enough, do NOT use an extension cord. Have a licensed electrician replace the power cord.**

PLEASE NOTE: MINI TANKS ARE FOR INDOOR PERMANENT INSTALLATIONS ONLY. BEFORE POWERING THE WATER HEATER, BE SURE THAT THE SYSTEM IS COMPLETELY FILLED WITH WATER AND ALL AIR IS REMOVED. THIS MANUAL AND ALL ECCOTEMP CONTENT IS SUBJECT TO CHANGE WITHOUT NOTICE. PLEASE VISIT SUPPORT.ECCOTEMP.COM FOR MORE INFORMATION.

# Eccotemp SMARTHOME Mobile App

## Connect your Water Heater to your Smart Devices

The Eccotemp **SMARTHOME** Mini Tank Water Heater has an easy to use mobile app that will allow you to control functions such as ON/OFF and temperature adjustments. Our mobile app is compatible with **SMARTHOME** devices, such as Amazon Alexa and Google Home, giving you voice command capability. Let our **SMARTHOME** app tell you exactly how much money you spend heating water.



### Temperature

The temperature of the **SMARTHOME** water heater can be remotely changed from the Eccotemp app.



### Instant Statistics

Observe water and electricity usage easily by checking the statistics page. Here you can see how much it costs to use your **SMARTHOME** water heater, and how much you are saving.

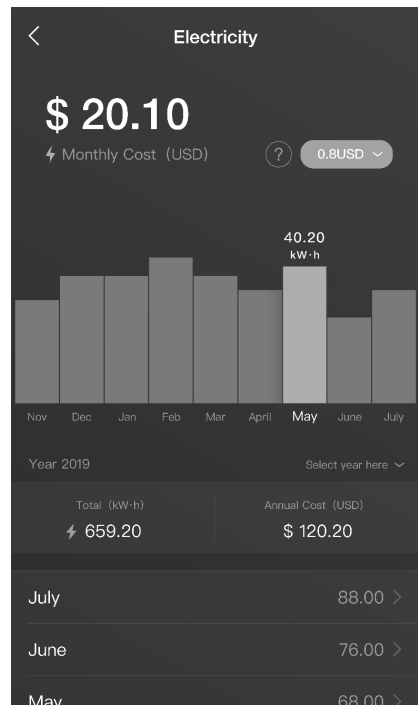
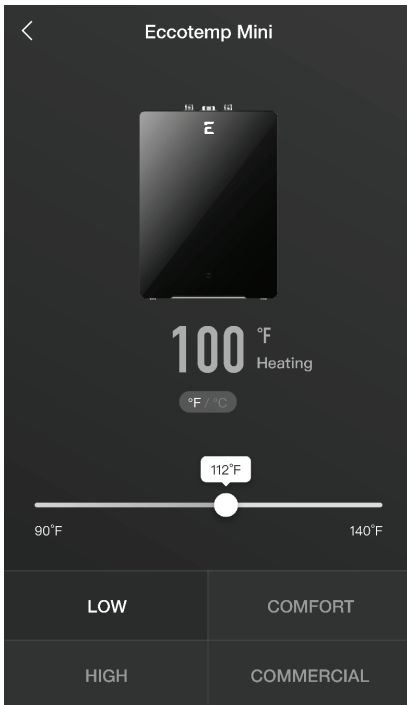

PLEASE NOTE: MINI TANKS ARE FOR INDOOR PERMANENT INSTALLATIONS ONLY. BEFORE POWERING THE WATER HEATER, BE SURE THAT THE SYSTEM IS COMPLETELY FILLED WITH WATER AND ALL AIR IS REMOVED. THIS MANUAL AND ALL ECCOTEMP CONTENT IS SUBJECT TO CHANGE WITHOUT NOTICE. PLEASE VISIT SUPPORT.ECCOTEMP.COM FOR MORE INFORMATION.

# Eccotemp SMARTHOME Mobile App Continued...



## Error Codes

The Eccotemp **SMARTHOME** water heater app has a troubleshooter to diagnose any device errors, which will help keep your **SMARTHOME** water heater running in top shape.



## Network Error

The built in network troubleshooter will tell you if there is a wifi problem.

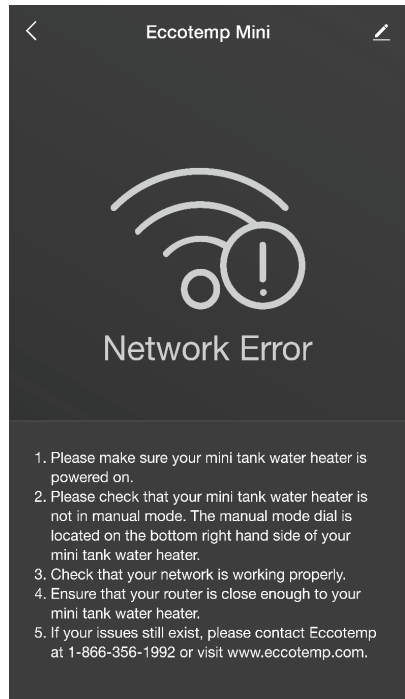
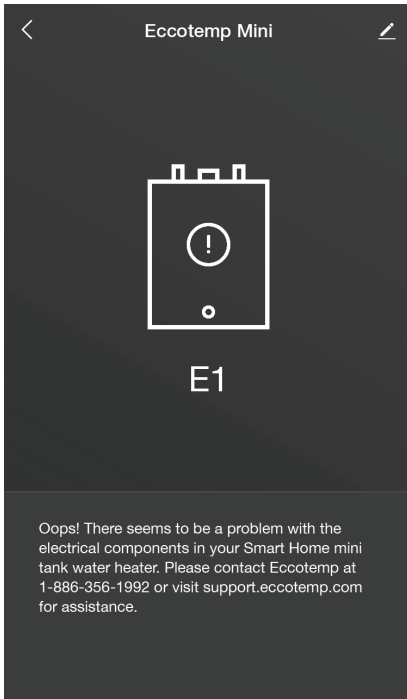

Have a problem with your Eccotemp water heater? The Eccotemp **SMARTHOME** app can tell you exactly what the problem is. Download it today to unlock your **SMARTHOME** water heater's full capabilities. Simply search for "Eccotemp" on the Apple App Store or Google Play.

PLEASE NOTE: MINI TANKS ARE FOR INDOOR PERMANENT INSTALLATIONS ONLY. BEFORE POWERING THE WATER HEATER, BE SURE THAT THE SYSTEM IS COMPLETELY FILLED WITH WATER AND ALL AIR IS REMOVED. THIS MANUAL AND ALL ECCOTEMP CONTENT IS SUBJECT TO CHANGE WITHOUT NOTICE. PLEASE VISIT SUPPORT.ECCOTEMP.COM FOR MORE INFORMATION.

# Getting Started

## SETTING TEMPERATURE

**⚠ WARNING!** This water heater is designed for 110/120v service - **DO NOT CONNECT TO ANY OTHER VOLTAGE.** Failure to use proper voltage may result in personal injury and/or property damage. If the supplied electrical power cord is either damaged or not long enough, do NOT use an extension cord. Have a licensed electrician replace the power cord.

**Congratulations!** You are now ready to use your water heater. Run the hot water at a nearby sink and evaluate the hot water temperature. Make any temperature adjustments using the section below.

## ADJUSTING YOUR THERMOSTAT

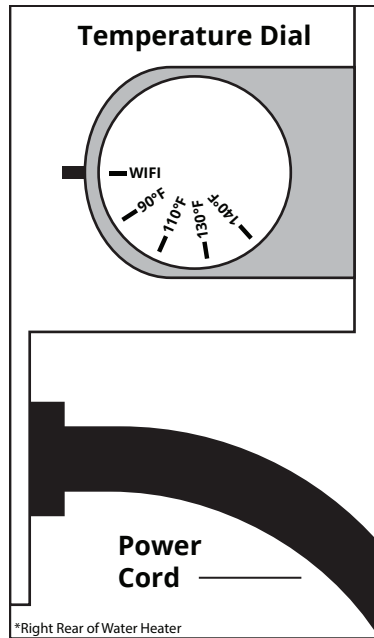
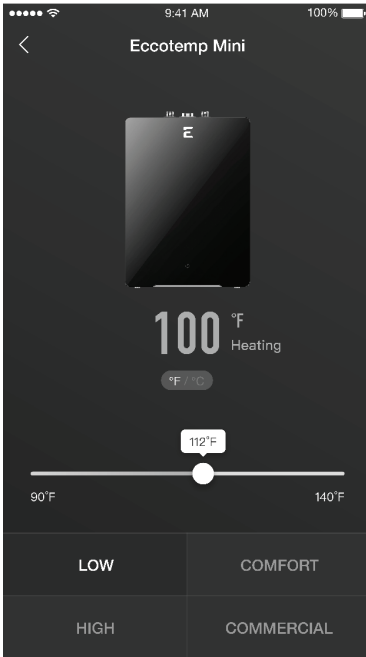

**Manual Mode:** Turn the dial in either direction to adjust your temperature up or down. Turn clockwise to increase temperature and turn counterclockwise to decrease temperature. Repeat this step until you achieve your desired temperature.

**Using the App:** Your Mini Tank will connect to your smart devices and smart phone to allow you to change the temperature.

**Note:** When in manual mode you WILL NOT be able to control the Mini Tank remotely through the **SMARTHOME** app.

PLEASE NOTE: MINI TANKS ARE FOR INDOOR PERMANENT INSTALLATIONS ONLY. BEFORE POWERING THE WATER HEATER, BE SURE THAT THE SYSTEM IS COMPLETELY FILLED WITH WATER AND ALL AIR IS REMOVED. THIS MANUAL AND ALL ECCOTEMP CONTENT IS SUBJECT TO CHANGE WITHOUT NOTICE. PLEASE VISIT SUPPORT.ECCOTEMP.COM FOR MORE INFORMATION.



# Getting Started

## USING THE APP

### 1. Download the App to get Started

Find and download the Eccotemp smart phone app on the Apple App Store or the Google Play Store by typing "Eccotemp" into the search panel.

### 2. Setup and Login

Once the app is installed, create a login and connect the app to the water heater. Follow the directions on screen and make sure the temperature knob, located on the back right side of the water heater, is set to wifi mode to complete the process.

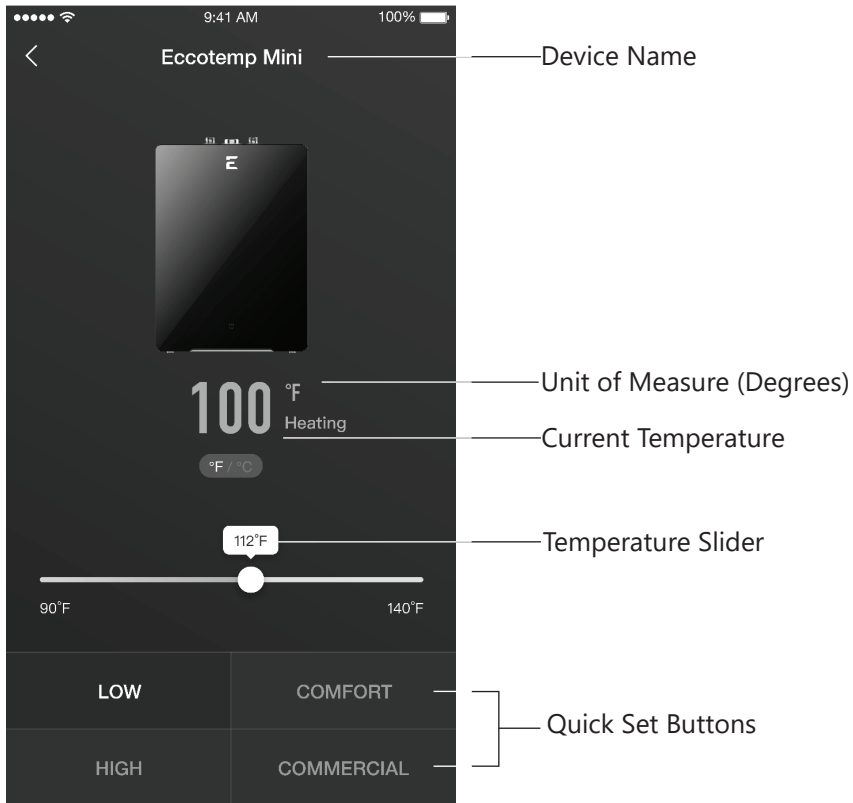

PLEASE NOTE: MINI TANKS ARE FOR INDOOR PERMANENT INSTALLATIONS ONLY. BEFORE POWERING THE WATER HEATER, BE SURE THAT THE SYSTEM IS COMPLETELY FILLED WITH WATER AND ALL AIR IS REMOVED. THIS MANUAL AND ALL ECCOTEMP CONTENT IS SUBJECT TO CHANGE WITHOUT NOTICE. PLEASE VISIT [SUPPORT.ECCOTEMP.COM](http://SUPPORT.ECCOTEMP.COM) FOR MORE INFORMATION.

# Getting Started

## Using the App

### 3. Using the App

After connecting the **SMARTHOME** app to the Mini Tank, you will be able to remotely control the temperature and on/off status of the Mini Tank water heater. There is an energy statistics screen that will allow you to track your usage and help you manage your water heater's energy consumption. Regularly using and reviewing the app will help you fine tune your water heating needs, while helping you use less resources to do so, ultimately saving you money.

### 4. Getting Connected

Connect your Eccotemp **SMARTHOME** Mini Tank to other **SMARTHOME** devices like Amazon Alexa and Google Home. Once connected, the Eccotemp **SMARTHOME** Mini Tank can accept voice commands such as, "Ok Google, turn my mini off."

### 5. Other Button Functions

- Button blinking rapidly for 120 seconds: This is when the mini is in wifi connection mode. To start or repeat connection mode hold down the on/off button for 10 seconds.
- Solid blue power button means the mini is off.
- When using the manual mode dial, the Eccotemp smart app will not work.
- The Mini Tank water heater will default to 118 degrees fahrenheit if a temperature is not set with the app or the knob.

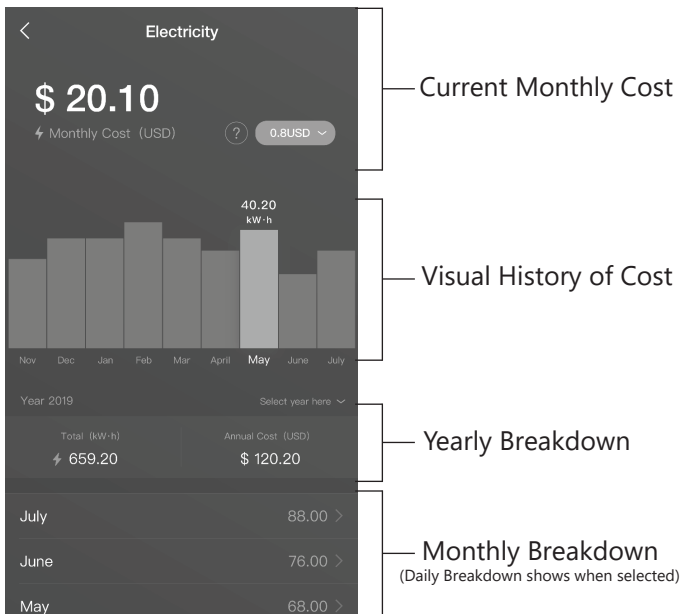

PLEASE NOTE: MINI TANKS ARE FOR INDOOR PERMANENT INSTALLATIONS ONLY. BEFORE POWERING THE WATER HEATER, BE SURE THAT THE SYSTEM IS COMPLETELY FILLED WITH WATER AND ALL AIR IS REMOVED. THIS MANUAL AND ALL ECCOTEMP CONTENT IS SUBJECT TO CHANGE WITHOUT NOTICE. PLEASE VISIT SUPPORT.ECCOTEMP.COM FOR MORE INFORMATION.

# Getting Started

## Using Voice Commands

The Eccotemp ESH Mini Tank Water Heater is the first **SMARTHOME** water heater of its kind to work with a mobile app and voice control. Once you open your Google Home or Amazon Alexa App simply add your **SMARTHOME** Mini Tank by adding a new device. Once added to either app you will then be able to use voice commands.

**Note:** All commands begin with “Alexa,” or “Ok, Google,” before issuing a command to the respective device.

	Purpose	Command
Amazon Alexa		
	Switch On/ Off	Turn on <device name> Turn off <device name>
	Set Temperature	Set <device name> to <X> degrees. Decrease <device name> Increase <device name>
	Querying the Set Temperature	What’s my <device name> set to?
Google Home		
	Switch On/Off	Turn on <device name> Turn off <device name>
	Setting theTemperature	Set the <device name> to <X> Make <device name> warmer/cooler
	Querying the Set Temperature	What’s the <device name> set to?

**Note:** This chart is for demonstration purposes only and available voice commands may vary based on model, updates and location availability.

# Maintenance

**⚠ NOTICE! When not being used for a lengthy period of time, you can conserve energy by reducing the temperature setting either manually or through the Eccotemp App.**

Protect against freeze damage if you plan on not using the water heater for an extended period of time. Unplug your water heater and drain.

## HOUSEKEEPING

When properly maintained, your water heater will provide years of dependable trouble-free service. It is recommended that a periodic inspection of the pipe connections be done every 6 months.

At least once a year, lift and release the lever handle on the pressure relief valve. It is located between the hot and cold water lines and make certain the valve operates freely. Allow several gallons to flush through the discharge line to an open drain.

Inspect the area around the water heater to ensure a safe operating environment. Keep the water heater area clear and free from any objects that could damage the water heater. If damage or denting is present, contact a service personnel to verify proper operation.

**DO NOT** operate the water heater if you feel something is wrong.

**DO NOT** allow children to operate or otherwise handle the water heater.

**⚠ NOTICE! If the pressure relief valve on the hot water heater discharges periodically, this may be due to a problem in the water system. Contact the water supplier or your plumbing contractor on how to correct this. DO NOT plug the relief valve outlet.**

## DRAINING AND STORAGE

Draining your water heater:

1. Unplug the water heater.
2. Open a hot water faucet to let hot water run out. Allow water to flow until water is no longer hot.
3. Turn off the cold water supply to the water heater.
4. Close the hot water faucet.
5. Disconnect the water heater from both the hot and cold water connections.
6. If possible, siphon out any remaining water.
7. Carefully detach the water heater from the wall (if applicable).
8. Tilt the water heater to drain remaining water out of the heater.

PLEASE NOTE: MINI TANKS ARE FOR INDOOR PERMANENT INSTALLATIONS ONLY. BEFORE POWERING THE WATER HEATER, BE SURE THAT THE SYSTEM IS COMPLETELY FILLED WITH WATER AND ALL AIR IS REMOVED. THIS MANUAL AND ALL ECCOTEMP CONTENT IS SUBJECT TO CHANGE WITHOUT NOTICE. PLEASE VISIT [SUPPORT.ECCOTEMP.COM](http://SUPPORT.ECCOTEMP.COM) FOR MORE INFORMATION.

# Maintenance

## BLOW OUT DIAGRAM

Numbers correspond with chart on page 22

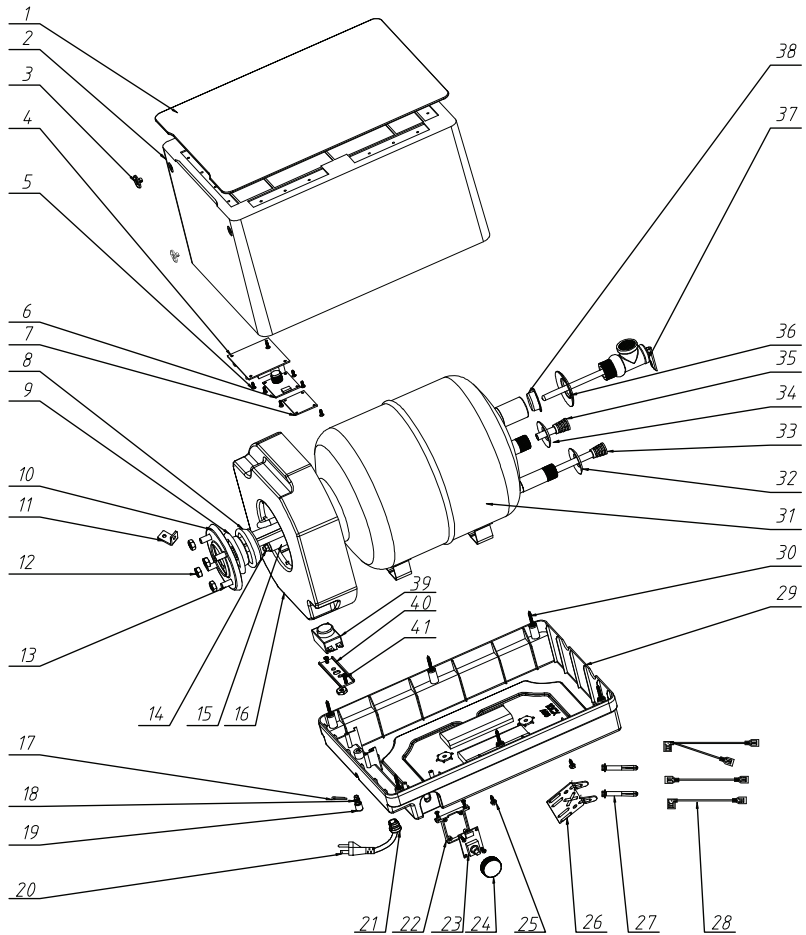

PLEASE NOTE: MINI TANKS ARE FOR INDOOR PERMANENT INSTALLATIONS ONLY. BEFORE POWERING THE WATER HEATER, BE SURE THAT THE SYSTEM IS COMPLETELY FILLED WITH WATER AND ALL AIR IS REMOVED. THIS MANUAL AND ALL ECCOTEMP CONTENT IS SUBJECT TO CHANGE WITHOUT NOTICE. PLEASE VISIT [SUPPORT.ECCOTEMP.COM](http://SUPPORT.ECCOTEMP.COM) FOR MORE INFORMATION.

# Maintenance

\*Chart corresponds with diagram on page 20

No.	Part Name	QTY
1	Front Panel (Tempered Glass)	1
2	Front Cover	1
3	Foot Pads	2
4	Power Control PCB	1
5	Self-Tap Screws- C	11
6	Front Control PCB	1
7	Wifi PCB	1
8	Element Sealing Ring	1
9	Heating Element	1
10	Flange Cover	1
11	L Shape Bracket	2
12	Nut(M8)	4
13	Square Head Bolt (M8)	4
14	Magnesium Anode Nut (M6)	1
15	Magnesium Anode Nut	1
16	Plastic Base	1
17	Reset Button Pin	1
18	Spring	1
19	Exterior Reset Button	1
20	Power Cord	1
21	Power Cord Clamp	1
22	Plastic Base	1
23	Temperature Control PCB	1
24	Control Knob	1
25	External Heagon Bolt (Self-tap)	2
26	Mounting Bracket	1
27	Expansion Bolt(M6)	2
28	Internal Wires	1
29	Back Cover	1
30	Cover Installation Screws	6
31	Inner Tank	1
32	Rubber Bushing (Blue)	1
33	Inlet Pipe	1
34	Rubber Bushing (Red)	1
35	Outlet Pipe	1
36	Rubber Bushing (T&P tube)	1
37	T&P valve	1
38	Rubber Cover (T&P tube)	1
39	Temperature Limiter	1
40	Temperature Limiter Bracket	1
41	Self-tap Screws (3.5*16)	2

PLEASE NOTE: MINI TANKS ARE FOR INDOOR PERMANENT INSTALLATIONS ONLY. BEFORE POWERING THE WATER HEATER, BE SURE THAT THE SYSTEM IS COMPLETELY FILLED WITH WATER AND ALL AIR IS REMOVED. THIS MANUAL AND ALL ECCOTEMP CONTENT IS SUBJECT TO CHANGE WITHOUT NOTICE. PLEASE VISIT SUPPORT.ECCOTEMP.COM FOR MORE INFORMATION.

# Troubleshooting

## BEFORE YOU CALL FOR SERVICE

Save time and money! Review the troubleshooting tips below first and you may not need to call for service.

### 1. Water does not get hot:

- Make sure the power supply is on and working.
- If the light does not come on, check to see if the reset button has been toggled into the reset position. The reset button can be found on the back of your Mini Tank towards the bottom.
- If the power button is illuminated, but water temperature does not get hot at the sink, test for a plumbing crossover by shutting off the cold water supply to the water heater and opening the hot water tap (there should be no water flowing). Any continuous flow indicates a cross over which will effect the temperature and will need to be corrected.
- If you are unable to determine a plumbing crossover by this method, replacing the heating element may be needed.

### 2. Power Button not on:

- If the power indicator button light does not come on but the water gets hot, check for faulty power indicator button bulb.
- Check reset button.

### 3. Brown Water:

Brown or rusty water indicates a spent anode rod. Replace anode rod.

### 4. Odor in Water:

Smelly water could be due to an unusual reaction between local water and the heater's anode rod. Check anode rod.

### 5. Water is too hot:

Turn the temperature knob to a lower temperature setting, or use the app to set the temperature to a lower setting. If the water temperature does not lower within 60 minutes, then the thermostat may need to be replaced.

### 6. Water is not hot enough:

See "Adjusting your Thermostat:" on page 16.

### 7. Water is leaking:

- Unplug water heater from 110/120v outlet.
- Check and tighten any loose water fittings and/or T&P fitting on the top of the tank as needed.
- Remove cover and inspect heating element gasket to see if it is loose or for any visible damage.

# Troubleshooting

## Error Codes on the Front Panel and the App

Your Ecotemp **SMARTHOME** Mini Tank can report 2 different errors. If you are using the app, it will explain how you can interact with the water heater itself to diagnose and fix some of the problems. You can also look at the power button and it will blink in a sequence based on the error it is reporting.

### Error Code 1: Thermostat Malfunction

When the Mini reports an E1 Error, the power button will blink blue once (1 time) every three (3) seconds until the issue is fixed.

If you have an E1 Error, please contact customer service.

### Error Code 2: Rapid Temperature Increase

When the Mini reports an E2 Error, the power button will blink blue twice (2 times) and then pause for three (3) seconds before repeating until the issue is fixed.

A rapid temperature increase is typically caused by the Mini not being full with water. Disconnect the Mini from power, fill the Mini with water, and reconnect the Mini to power to resolve this issue. If the E2 error code does not resolve, please reach out to customer service for further assistance.

### No Power:

If the Mini does not seem to have power even though it is plugged in, check the reset button on the back of the Mini to make sure it is not toggled into the reset position. If the reset button is not toggled to the reset position, please contact customer service for further assistance.

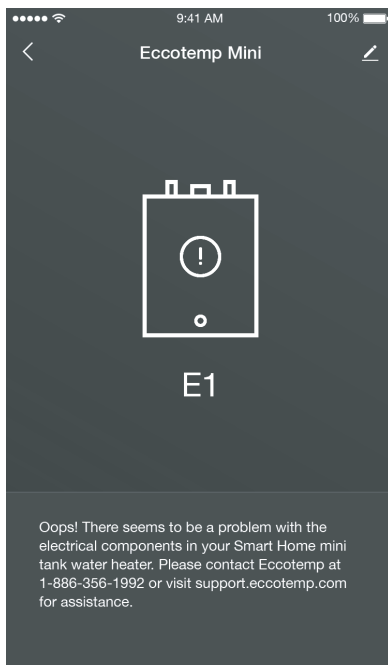

### Wifi Connectivity:

When your Ecotemp **SMARTHOME** Mini Tank is connecting to wifi, you will see the power button on the front of the Mini Tank blinking red for up to 60 seconds while it connects. If it is unable to connect during that time, it will try again periodically for up to 15 minutes.

In the event that your water heater does not connect to your wifi, it will automatically set the temperature to the default temperature of 118° Fahrenheit. Your app will be able to tell you if your heater has connected successfully.



# Eccotemp Systems ,LLC

## Limited Warranty Information

### Model (s): ESH Series Mini-tank (ESH-2.5, ESH-4.0)

#### I. LIMITED WARRANTY

Subject to the terms below, Eccotemp Systems, LLC ("Eccotemp") provides this limited warranty (the "Limited Warranty") to cover the following Products and Covered Components:

PRODUCT NAME	COVERED COMPONENTS
ESH Series Mini-tank (ESH-2.5, ESH-4.0) Water Heater	ESH Series Mini-tank (ESH-2.5, ESH-4.0) Water Heater; ETL certified fittings, accessories, and mounting hardware

This Limited Warranty is being provided to the original purchaser and subsequent owners (the "Owner"), but only while the Product remains as the site of the original installation.

#### II. LIMITED WARRANTY PERIOD

The term of this Limited Warranty (the "Warranty Period") begins on the date of purchase and ends as set forth below:

##### 5 YEAR WARRANTY

The covered components, except for the Heat Element, in the Product are warranted by Eccotemp for a period of five (5) years from the date of purchase when installed according to Eccotemp's Installation and Operating Instructions.

##### 2 YEAR WARRANTY

The Heat Element in the Product is warranted by Eccotemp for a period of two (2) years from the date of purchase when installed according to Eccotemp's Installation and Operating Instructions.

##### 30 DAY WARRANTY

All accessories that have been provided with the Product at no cost are warranted by Eccotemp for a period of thirty (30) days from the date of purchase when installed according to Eccotemp's Installation and Operating Instructions.

#### III. WARRANTY COVERAGE

If, during the Warranty Period, a component in the Product fails because of a manufacturing defect, Eccotemp will repair, replace, or refund the Product to the Owner at Eccotemp's sole discretion and as determined to be appropriate by the Eccotemp Support Team. As set forth in Section IV, the Owner may be responsible for all shipping, freight, and handling charges, as well as all fees and costs associated with the warranty service, including, but not limited to, all labor and other costs involved in diagnostic calls or in removing, repairing, servicing, or replacing any component. Eccotemp's sole responsibility under this Limited Warranty is to repair, replace, or refund the cost of the Product at Eccotemp's sole discretion. In the event that an exact replacement component is no longer available, Eccotemp will, at its option, provide a substitute component that Eccotemp deems suitable for the Product. If the Owner reports a subsequent issue with any covered component in the Product, the Owner may be responsible for retaining the failed component(s) for 90 days after a warranty claim is filed and must surrender the component(s) at the request of Eccotemp.

Both Eccotemp and the Owner of the Product are bound by this Limited Warranty.

#### IV. MAKING A WARRANTY CLAIM

To make a warranty claim through this Limited Warranty, the Owner must contact Eccotemp's Customer Service team at support@eccotemp.com, schedule a call or live chat on the Eccotemp support page at <http://support.eccotemp.com>. It is within Eccotemp's sole discretion when a repair, replacement, or refund will be issued. Any return for refund must be approved by Eccotemp's Customer Service team prior to shipping the Product back to Eccotemp. Please refer to Returning Your Product For Repair or Refund Policy provided with the Product.

Within the first 45 days of purchase, Eccotemp will cover all ground shipping costs for warranty related issues in the US and Canada, excluding Alaska, Hawaii and any location outside of the continental US and Canada. After the first 45 days of purchase, the Owner is responsible for all shipping to Eccotemp, regardless of reason or circumstance. Eccotemp will cover the warranty related shipping costs when returning the Product to the Owner after repair/inspection. The method for warranty related shipping will be ground equivalent with the provider within Eccotemp's sole discretion.

What information you will need for processing of your warranty claim:

- Proof of purchase
- Serial number
- Photos of the installation
- Photos of the damage point (if there is one)

All shipments of any type of product coming to Eccotemp for any reason must have a Return Goods Authorization ("RGA") number for any repairs to be made. Please contact Eccotemp to obtain an RGA number prior to shipping anything to Eccotemp. Failure to do so could result in loss of Product. Eccotemp will not be responsible for replacement due to loss or damage if these steps are not properly followed.

Any returns to Eccotemp must be sent in the original packaging. If your returned product does not have the original packaging and/or is missing any of the components that came with the product, there will be a nonnegotiable 15% restock fee.

PLEASE NOTE: MINI TANKS ARE FOR INDOOR PERMANENT INSTALLATIONS ONLY. BEFORE POWERING THE WATER HEATER, BE SURE THAT THE SYSTEM IS COMPLETELY FILLED WITH WATER AND ALL AIR IS REMOVED. THIS MANUAL AND ALL ECCOTEMP CONTENT IS SUBJECT TO CHANGE WITHOUT NOTICE. PLEASE VISIT SUPPORT.ECCOTEMP.COM FOR MORE INFORMATION.

# Eccotemp Systems ,LLC

## Limited Warranty Information

Model (s): Model (s): ESH Series Mini-tank (ESH-2.5, ESH-4.0)

### V. DISCLAIMER OF WARRANTIES AND RESPONSIBILITY FOR DAMAGES

EXCEPT AS PROVIDED IN THIS LIMITED WARRANTY, ECCOTEMP MAKES NO WARRANTY, EXPRESS OR IMPLIED, TO ANYONE AS TO FITNESS FOR ANY PURPOSE, MERCHANTABILITY, DESIGN, CONDITION, CAPACITY, PERFORMANCE, OR ANY OTHER ASPECT OF THE PRODUCT OR ITS MATERIAL OR WORKMANSHIP. ALL IMPLIED WARRANTIES WHICH MAY EXIST, NOTWITHSTANDING THIS DISCLAIMER, ARE LIMITED TO THE DURATION OF THIS LIMITED WARRANTY. THIS LIMITED WARRANTY IS MADE IN LIEU OF ALL OTHER GUARANTEES, WARRANTIES, REPRESENTATIONS, CONDITIONS, OBLIGATIONS, OR LIABILITIES, EXPRESS OR IMPLIED.

ECCOTEMP SHALL NOT BE LIABLE, EITHER IN CONTRACT OR TORT, FOR ANY DIRECT, INDIRECT, INCIDENTAL OR CONSEQUENTIAL DAMAGES, OR ANY LOSS, DAMAGE, OR INJURY TO PERSONS, INCLUDING DEATH, PROPERTY, OR THINGS, OR FOR DAMAGES OF ANY KIND OR NATURE INCLUDING BUSINESS INTERRUPTION, INCONVENIENCE OR LOSS OF ANTICIPATED PROFITS OR SAVINGS OCCASIONED BY OR ARISING OUT OF THE USE, MISUSE, NONUSE, REPAIR, REPLACEMENT OR DELAY IN DELIVERY OF THE PRODUCT. ECCOTEMP SHALL NOT BE LIABLE FOR THE COST OF ANY WORK DONE BY PURCHASER OR OTHERS TO THE PRODUCT.

This Limited Warranty gives specific legal rights. Some jurisdictions do not allow the exclusion or limitation of implied warranties or incidental or consequential damages. In such jurisdictions, the limitations or exclusions do not apply to the Owner. The Owner may also have other rights that may vary by jurisdiction.

### VI. EXCLUSIONS

The following exclusions apply to this Limited Warranty:

1. A repair, replacement, or refund will not be provided under this Limited Warranty unless the Product containing the defective component is properly installed and maintained according to Eccotemp's Installation Manual and Use & Care Manual and in compliance with all applicable federal, state/province, and local laws, regulations, codes, policies, and licensing requirements. Any abuse, misuse, alteration, neglect, or misapplication of the Product will render this Limited Warranty null and void.
2. A repair, replacement, or refund will not be provided if the Product is damaged by services performed by third party service providers other than Eccotemp Systems.
3. Eccotemp systems is not responsible for any expenses arising from labor services, including but not limited to, installation or removal services due to a warranty claim.
4. A repair, replacement, or refund will not be provided if the Product is used in a hot water circulation loop, in series with a circulation system, where an on-demand recirculation system is incorporated, or in any other corrosive or otherwise destructive environment where the Product is not intended to be used as set forth in Eccotemp's Installation Manual and Use & Care Manual.
5. A repair, replacement, or refund will not be provided if the Product is damaged as a result of improper installation, including improper ventilation materials, sizing, length, elevation, condensation drainage, or inadequate airflow.
6. A repair, replacement, or refund will not be provided if the Product is damaged as a result of improper use, including freezing within the unit or surrounding piping, incorrect sizing for the application, scale build up, or incorrect gas and/or water pressure.
7. This Product shall not be used as a pool or spa heater. Use of the Product as a pool or spa heater shall be considered misuse and will render this Limited Warranty null and void.
8. A repair, replacement, or refund will not be provided if the Product is damaged by the use of non-potable, untreated or poorly treated well water, or water with high PH levels or hardness levels in excess of 12 grains per gallon (200 mg/L).
9. A repair, replacement, or refund will not be provided under this Limited Warranty if the original serial number on the Product has been removed or altered in a way that causes the serial number to not be readily determined.
10. Eccotemp will not pay electricity or fuel costs, or increases in electricity or fuel costs, for any reason whatsoever, including additional or unusual use of supplemental electrical heat.
11. Eccotemp will not be responsible for any default or delay in performance under this Limited Warranty caused by any factor or contingency outside of its control.

### VII. MISCELLANEOUS

No agent, employee or representative of Eccotemp has any authority to bind Eccotemp to any representation or warranty concerning the Product not contained in this Limited Warranty. Eccotemp reserves the right and authority to change, modify or alter this warranty at any given time.  
For Customers With a Home Warranty

Often your home warranty will assist in covering some of the fees related to your home appliances, such as your water heater. Be sure to check with your home warranty company for assistance prior to reaching out to Eccotemp.

PLEASE NOTE: MINI TANKS ARE FOR INDOOR PERMANENT INSTALLATIONS ONLY. BEFORE POWERING THE WATER HEATER, BE SURE THAT THE SYSTEM IS COMPLETELY FILLED WITH WATER AND ALL AIR IS REMOVED. THIS MANUAL AND ALL ECCOTEMP CONTENT IS SUBJECT TO CHANGE WITHOUT NOTICE. PLEASE VISIT SUPPORT.ECCOTEMP.COM FOR MORE INFORMATION.

## Product Comparison

If you like the Eccotemp **SMARTHOME** Mini Tank, you'll also like our ESH Series Mini Tanks! You can get more information about these miniature tanks and Eccotemp's Tankless Water Heaters at [www.Eccotemp.com](http://www.Eccotemp.com)

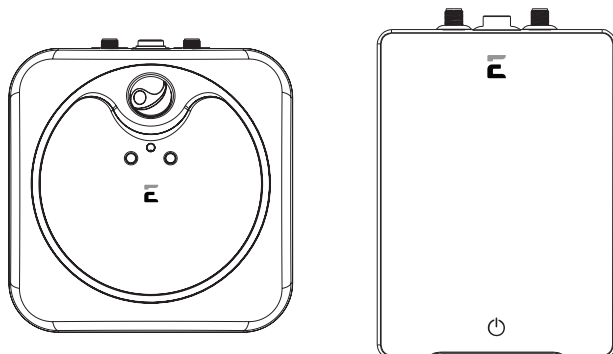

	EM Series Mini Tank	ESH Series Mini Tank
INSTALLATION	INDOOR ONLY	INDOOR ONLY
Tank Volume	2.5 Gallon, 4 Gallon, and 7 Gallon Models	2.5 Gallon and 4 Gallon Models
Voltage	110/120	110/120
AMPS	12	12
Phase	Single	Single
Temperatures	50-140 F	50-140 F
Heating Capacity	1400 Watts	1440 Watts
Max Operating Pressure	150 psi	150 psi
Fittings	1/2 NPT Connections	1/2 NPT Connections
Warranty	5 years Limited on Leaks 2 years Defects	5 years Limited on Leaks 2 years Defects
Outer Case	Plastic	Tempered Glass / Plastic
Manual Mode	✓	✓
SmartHome	✗	✓
Mobile App	✗	✓
Voice Commands	✗	✓
Smart ON/OFF	✗	✓
Advanced Error Detection	✗	✓
Suggested Uses	Boats, Campers, Tiny Homes, Food Carts, RV's Homes, Under the Sink, Offices, Cottages, Kitchens, Utility Rooms, Apartments, Food Trucks	Boats, Campers, Tiny Homes, Food Carts, RV's Homes, Under the Sink, Offices, Cottages, Kitchens, Utility Rooms, Apartments, Food Trucks

PLEASE NOTE: MINI TANKS ARE FOR INDOOR PERMANENT INSTALLATIONS ONLY. BEFORE POWERING THE WATER HEATER, BE SURE THAT THE SYSTEM IS COMPLETELY FILLED WITH WATER AND ALL AIR IS REMOVED. THIS MANUAL AND ALL ECCOTEMP CONTENT IS SUBJECT TO CHANGE WITHOUT NOTICE. PLEASE VISIT [SUPPORT.ECCOTEMP.COM](http://SUPPORT.ECCOTEMP.COM) FOR MORE INFORMATION.

**ECCOTEMP™**  
HEATING WATER SMARTER