

# SUPER SLIM

## 2-HANDLE THERMOSTATIC ROUGH WITH 2-WAY DIVERTER



- Ceramic disc valve cartridge
- Forged brass valve body with built-in check stops
- 2-Way Diverter options include discrete or shared functions
- 1/2" Wax thermostatic unit permits shuttle valve to move between the hot and cold seats to maintain the preselected constant water temperature
- 1/2" NPT Inlets/Outlets
- Includes Adjustable Hot Limit Safety Stop
- Maximum temperature limit is 120°F

### CODES AND STANDARDS

Meets or Exceeds ASME A112.18.1/CSA B125.1/ASSE 1016

### DESCRIPTION

2-Handle Thermostatic Rough Valve with 2-Way Diverter (Discrete Functions)

### PRODUCT NUMBER

D35005522.191

2-Handle Thermostatic Rough Valve with 2-Way Diverter (Shared Functions)

D35005522S.191

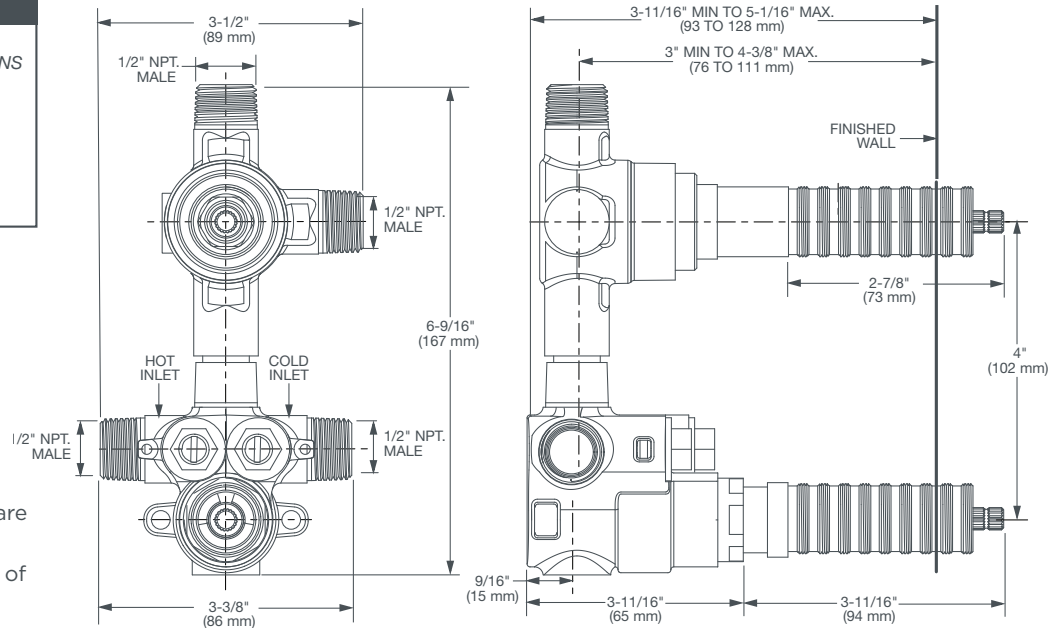
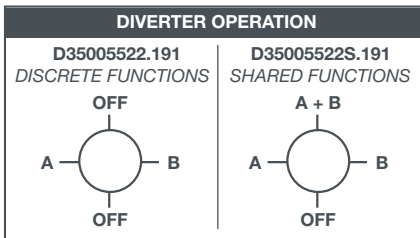

**IMPORTANT:** These measurements are subject to change or cancellation. No responsibility is assumed for use of superseded or voided pages.

CEC and CALGreen Compliant

PART OF **LIXIL**