

Starck 3

Mounting instructions

Instrucciones de montaje

安装说明

Notice de montage

One-piece toilet, Single flush

Inodoro de una pieza, Single flush

连体式座便器, 单冲水

Cuvette One Piece, Single flush

2120.1..01



Important information

4

Información importante

5

重要说明

6

Remarques importantes

7

en
es
zh
fr



Installation, Montaje, 安装, Montage

8



Important information

en

Regarding the mounting instructions

These mounting instructions come as part of the Duravit product and should be read carefully prior to installation.

Explanation of the key words and symbols

CAUTION Indicates a hazardous situation which, if not avoided, could result in minor or moderate injury.

NOTICE Is used to address practices not related to physical injury.

Inspection (e.g. for scratches)

Check for leaks and leak-tightness

Target readership and qualifications

The toilet must be installed by certified plumber.

CAUTION **Risk of physical injury, product damage or potential damage!**

- > Local installation regulations and any country-specific standards must be observed at all times.

Safety information

CAUTION **Risk of personal injury or breakage through fragile product!**

- > 2 people are recommended of handling.
- > Handle with care.

NOTICE **Risk of product damage!**

- > Overtightening may cause breakage or chipping of vitreous china.
- > Handle with care.

NOTICE **Risk of external leakage!**

- > Do not lift or rock the toilet after placement.
- > If you break the watertight seal, you must install a new wax seal.

Water installation

HET (high efficiency toilet):

- with single flush: 1.28 gpf / 4.8 lpf

Operation pressure:

Recommended: 20 – 80 psi / 140 – 550 kPA

Installation information

Please read pre-installation datasheets prior to the installation. These are available to download on the Internet at www.duravit.com.



Información importante

Sobre las instrucciones de montaje

Estas instrucciones de montaje forman parte del producto Duravit y deben leerse detenidamente antes de la instalación.

Explicación de las palabras clave y los símbolos

ATENCIÓN Indica una situación peligrosa que, si no se evita, puede producir lesiones de gravedad media o leve.

AVISO Se utiliza para referirse a prácticas no relacionadas con lesiones físicas.



Inspección (p. ej., arañazos)



Compruebe si hay fugas y la estanqueidad

Lectores destinatarios y cualificaciones

Un fontanero profesional debe instalar el inodoro.

ATENCIÓN ¡Existe el riesgo de que se produzcan lesiones físicas, daños en el producto o daños potenciales!

- > Deben observarse en todo momento los reglamentos locales de instalación y las normas específicas de cada país.

Información de seguridad

ATENCIÓN ¡Riesgo de lesiones personales o rotura del producto debido a la fragilidad del mismo!

- > Se recomienda la manipulación entre 2 personas.
- > Manipular con cuidado.

AVISO ¡Existe el riesgo de daños en el producto!

- > Un apriete excesivo puede provocar que la porcelana vidriada se rompa o se desconche.
- > Manipular con cuidado.

AVISO ¡Existe el riesgo de que se produzcan fugas externas!

- > No elevar ni balancear el inodoro después de colocarlo.
- > En caso de rotura del sellado estanco, debe instalar un nuevo sello de cera.

Instalación de agua

HET (inodoro de alta eficiencia):

- Descarga simple: 1,28 galones por descarga / 4,8 litros por descarga

Presión de funcionamiento:

Recomendada: 20 – 80 psi / 140 – 550 kPA

Advertencia acerca del montaje

Antes de llevar a cabo el montaje, tener en cuenta las fichas de preinstalación. Pueden descargarse en Internet del sitio web www.duravit.com.





重要说明

关于安装说明

此安装说明是 Duravit 产品的一部分，安装前应仔细阅读。

关于关键词与符号的说明

 **注意** 表示如不可避免可能会导致轻微或中度伤害的危险情况。

 **公告** 用于表示与身体伤害无关的操作实践。

 **要求视检** (比如检查划痕)

 **检查泄漏和密封性**

目标读者和安装人员资格

坐便器须由经认证的管道工安装。

 **注意** 身体伤害、产品损坏或潜在损坏风险！

- > 请务必遵守所在国家/地区的标准和当地安装规章条例。

安全信息

 **注意** 易碎产品破损或人身伤害风险！

- > 建议由两人同时处理。
- > 请谨慎操作。

 **公告** 产品损坏风险！

- > 过紧可能会导致玻璃陶瓷破损或碎裂。
- > 请谨慎操作。

 **公告** 外部泄漏风险！

- > 放置妥当后，请勿抬起或摇动坐便器。
- > 如果您损坏了防水密封盖，必须安装一个新的蜡封。

水管安装

HET (高效坐便器) :

- 单次冲洗: 1.28 gpf / 4.8 lpf

工作压力:

建议压强: 20 - 80 psi / 140 - 550 kPa

安装说明

安装前请注意查看装前数据表。数据表可从 www.duravit.com 下载。



Remarques importantes

À propos de cette notice de montage

Cette notice de montage fait partie intégrante du produit Duravit et doit être lue attentivement avant le montage.

Explication des mots clés et des symboles



Indique une situation dangereuse qui, si elle n'est pas évitée, peut occasionner des blessures mineures ou modérées.

AVIS

Est utilisée pour mettre en avant des pratiques qui ne sont pas en lien avec des blessures.



Inspection (par ex. des rayures)



Vérifier les fuites et l'étanchéité

Lecteurs cibles et qualifications

Les toilettes doivent être installées par un plombier certifié.



Risque de blessures, d'endommagement du produit ou de dommages potentiels !

- > Les réglementations d'installation locales et toutes les normes spécifiques au pays doivent être respectées à tout moment.

Consignes de sécurité



Risque de blessures ou de casse en raison de la fragilité du produit !

- > 2 personnes sont recommandées pour la manipulation.
- > Manipuler avec précaution.

AVIS

Risque d'endommagement du produit !

- > Un serrage trop fort peut entraîner des bris ou l'écaillage de la porcelaine vitrifiée.
- > Manipuler avec précaution.

AVIS

Risque de fuites externes !

- > Ne pas soulever ou basculer la toilette après la mise en place.
- > Si vous cassez le joint étanche, vous devez installer un nouvel anneau de cire.

Installation hydraulique

HET (toilette haute efficacité) :

- avec chasse simple : 1,28 gpf / 4,8 lpf

Pression de service :

Recommandée : 20 – 80 psi / 140 – 550 kPA

Consignes d'installation

Lire les fiches de pré-installation avant l'installation. Celles-ci peuvent être téléchargées sur Internet à l'adresse www.duravit.com.

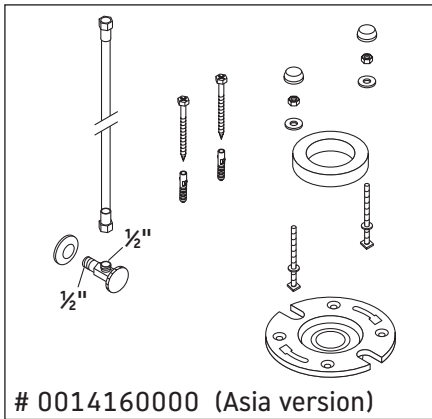
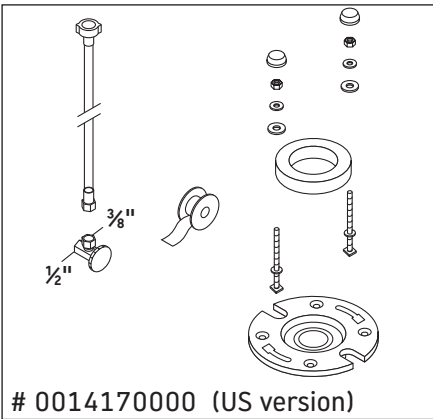
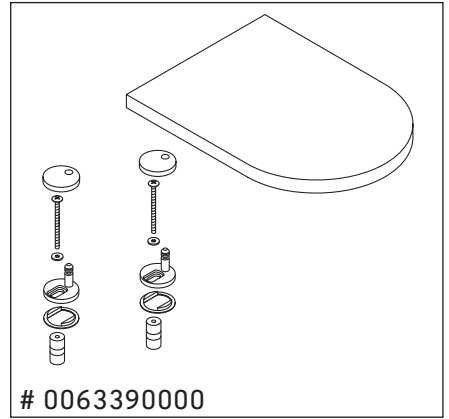
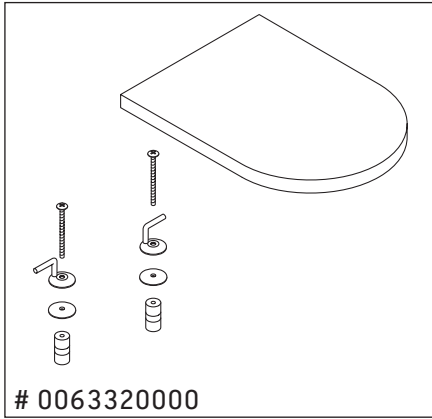
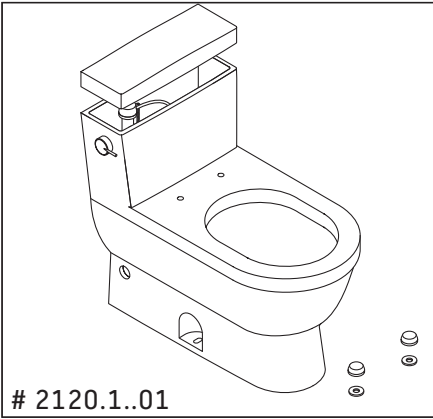

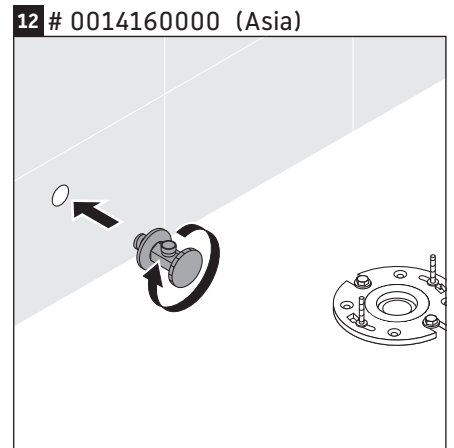
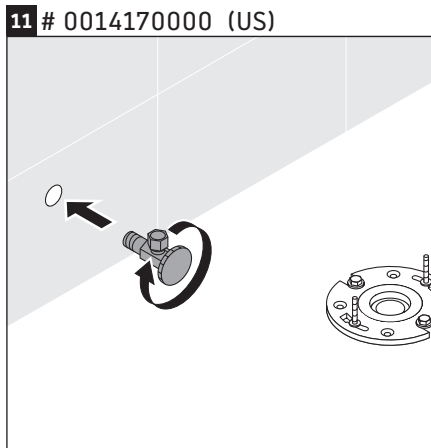
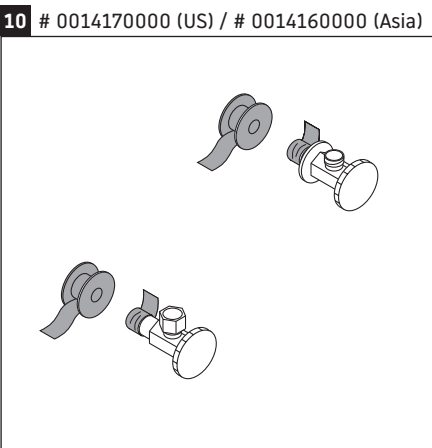
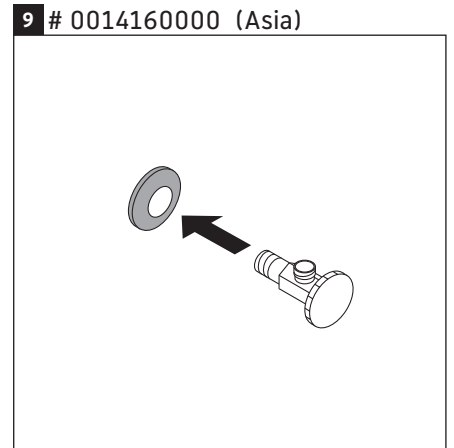
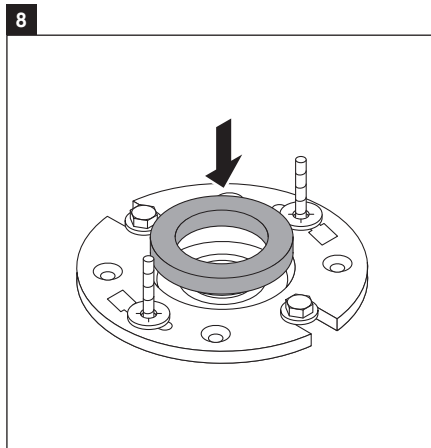
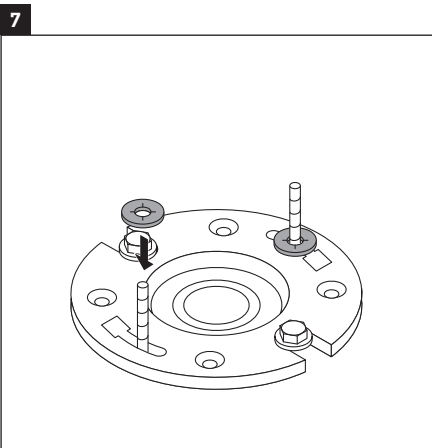
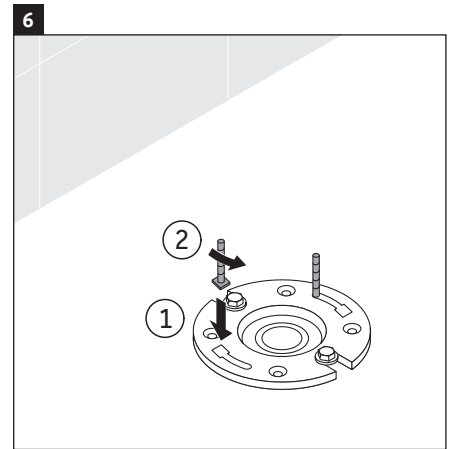
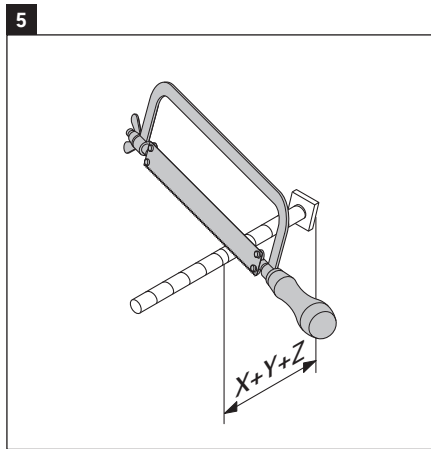
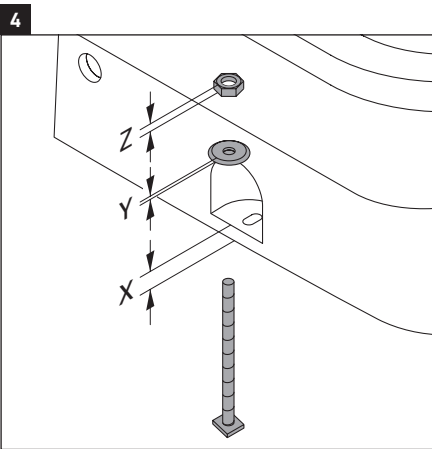
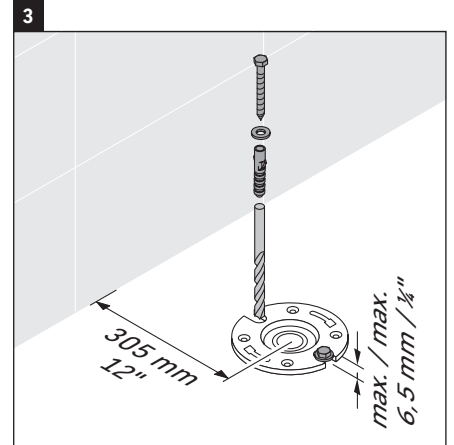
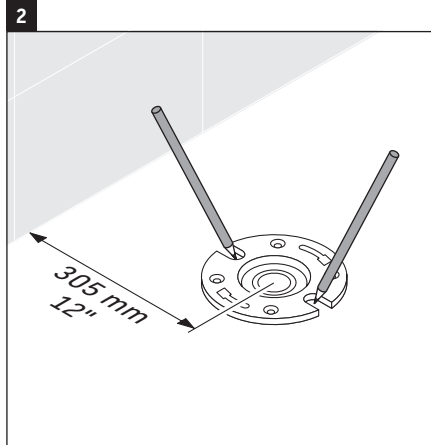
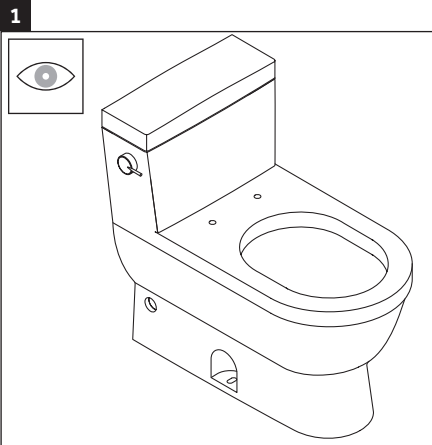

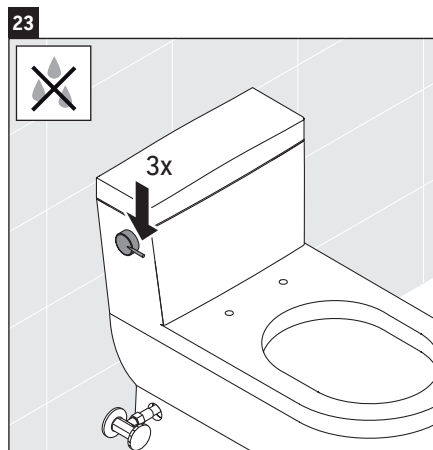
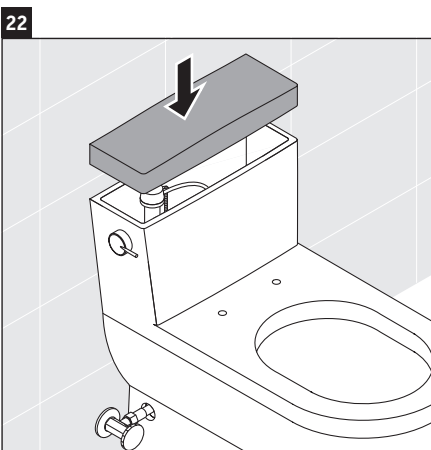
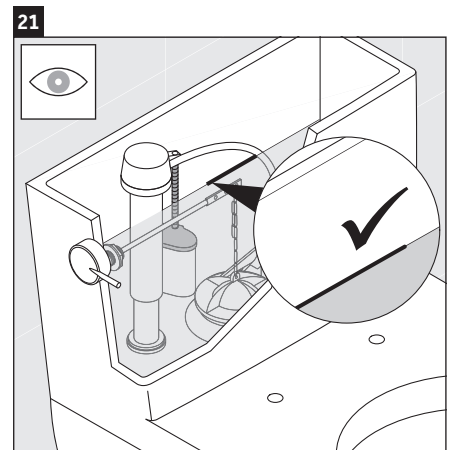
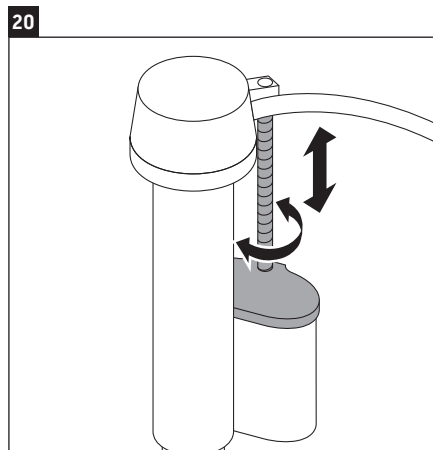
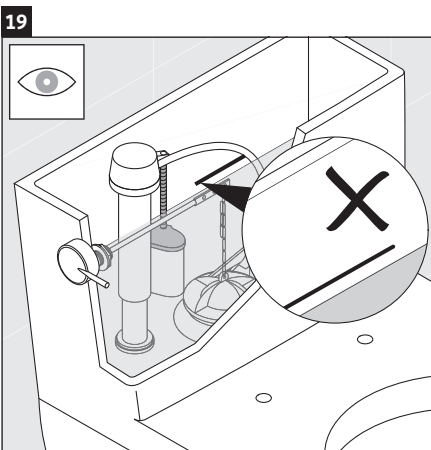
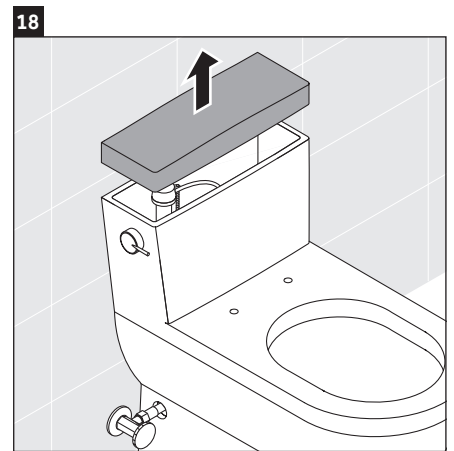
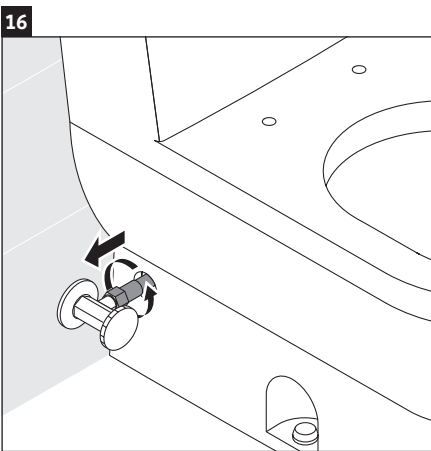
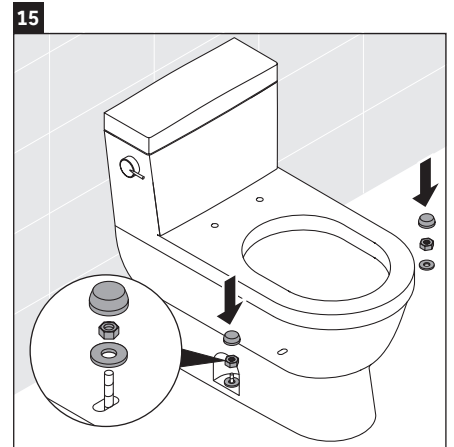
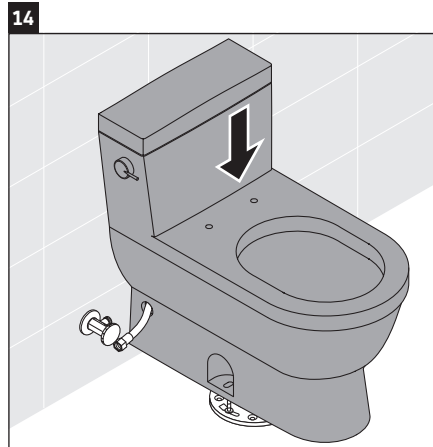
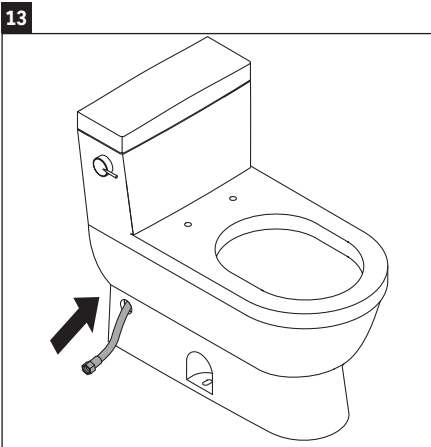

Duravit AG
P.O. Box 240
Werderstr. 36
78132 Hornberg
Germany
Phone +49 78 33 70 0
Fax +49 78 33 70 289
info@duravit.com
www.duravit.com

Duravit USA, Inc.
105 Madison Avenue
New York, NY 10016
Toll Free 888-DURAVIT
Phone 212 686 0033
Fax 212 686 8033
info@us.duravit.com
www.duravit.us

Duravit USA, Inc.
2635 North Berkeley Lake Road
Suite 100
Duluth, GA 30096
Phone +1 770 931 3575
Fax +1 770 931 8454
info@us.duravit.com
www.duravit.us

Duravit Shanghai Sales Center
Suite B-d, 10/F Jiu Shi Tower
No28 Zhongshan Road South
Shanghai P.C. 200010
Phone +86 21 63309922
Fax +86 21 63304808
info@cn.duravit.com
www.duravit.cn



SensoWash[®] Starck C

Mounting instructions

Instrucciones de montaje

Notice de montage

安裝說明

Shower toilet unit

Accesorio para el WC con ducha

Abattant WC douche

智慧馬桶座組件

610001 .. 1

610200 .. 1

610300 .. 1



Important information

Información importante

Remarques importantes

重要資訊

en
es
fr
zh-tw



Installation, Montaje, Montage, 安裝



Important information

About the mounting instructions

These mounting instructions come as part of the Duravit Shower WC and should be read carefully prior to installation.

Explanation of the key words and symbols

⚠ DANGER! At high risk of fatal hazards or serious injuries

NOTE! To avoid property damage



Link to the **installation information** in this section



Inspection (e.g. for scratches)

Target Readership and Qualifications

The Shower WC and associated water connection may only be installed by qualified plumbers. The electrical installation may only be carried out by qualified electricians.

NOTE!
Local installation regulations, country-specific standards and the low voltage directives must be observed at all times.

NOTE!
DO NOT install the Shower WC in rooms where there is a danger of frost. The room temperature must not be less than 4 °C.

NOTE!
Condensation may form when the Shower WC unit is brought from a cold location to a warm one.
> Leave the unit switched off for a few hours.

Safety instructions

⚠ DANGER!
Risk of fatal electric shock.

> Do NOT remove individual Shower WC components.

Installation Instructions

Please read pre-installation data sheets prior to the installation. These are available to download on the Internet at www.duravit.com.

An installation video of the complete shower WC is available at pro.duravit.com/mounting.



Simply use this QR code

1 Checking the installation requirements (Diagram 1)

- > The installation of the WC ceramics with pre-installation of the Shower WC water and power supplies is described in separate instructions. Ensure that the supplies and WC ceramics have been installed and mounted according to the instructions and regulations.

23 Positioning the remote control mounting bracket (Diagram 23)

- > Continue with step 26 to install the anti-theft device.
- > Follow the instructions up to step 25 to install the mounting bracket without the anti-theft device.

31 Removing the seat (Diagram 31)

- > Remove the seat as required, e.g. for cleaning



Instrucciones de montaje

Estas instrucciones de montaje acompañan al WC con ducha Duravit y es necesario leerlas cuidadosamente antes del montaje.

Explicación de las indicaciones y símbolos de advertencia

⚠ ¡PELIGRO! Riesgo elevado, peligro de muerte o lesiones graves

⚠ ¡ADVERTENCIA! Para evitar daños materiales



Indica **una advertencia acerca del montaje** en este capítulo



Fíjese que no haya, por ejemplo, arañazos

Instaladores y cualificación

El WC con ducha y la instalación correspondiente de agua solo pueden ser montados por instaladores de sanitarios con la formación adecuada. La instalación eléctrica solo podrán realizarla instaladores eléctricos cualificados.

¡ADVERTENCIA!

Deberán cumplirse sin restricciones las instrucciones de instalación de las empresas de suministro locales, las normas específicas de cada país y las directivas de baja tensión.

¡ADVERTENCIA!

NO monte el WC con ducha en espacios con riesgo de que se produzcan heladas. La temperatura ambiente no deberá ser inferior a los 4 °C.

¡ADVERTENCIA!

Si el accesorio del WC con ducha se cambia de un sitio frío a uno caliente, puede que se produzca humedad por condensación.

> Deje el equipo desconectado durante algunas horas.

Advertencias de seguridad

⚠ ¡PELIGRO!

Peligro de muerte por descarga eléctrica.

> NO desmontar los diferentes componentes del WC con ducha.

Indicaciones de montaje

Antes de llevar a cabo el montaje, tener en cuenta las fichas de preinstalación. Pueden descargarse en Internet del sitio web www.duravit.com.

Puede encontrar un vídeo de instalación de todo el WC con ducha en pro.duravit.com/mounting.



Use simplemente para ello este código QR.

1 Comprobar los requisitos de montaje (imagen 1)

> El montaje de la cerámica del WC con instalación previa de la alimentación de agua y de corriente del WC con ducha se describe en otras instrucciones. Asegúrese de que las alimentaciones y la cerámica del WC se instalen y se monten de conformidad con las instrucciones y las disposiciones.

23 Posicionar el soporte del mando a distancia (imagen 23)

> Proseguir con el paso 26 para el montaje del dispositivo antirrobo.
> Proseguir con el paso 25 para el montaje del soporte sin el dispositivo antirrobo.

31 Retirar el asiento (imagen 31)

> Retirar el asiento para la limpieza si es necesario.



Remarques importantes

Concernant la notice de montage

Cette notice de montage fait partie de l'abattant douche Duravit et doit être lue attentivement avant le montage.

Explication des avertissements et symboles

⚠ DANGER! En cas de risques élevés, dangers mortels, blessures graves

REMARQUE ! Pour éviter les dégâts matériels



Référence à la **Consigne de montage** dans ce chapitre



Invitation à vérifier (p. ex. les rayures)

Groupe cible et qualification

L'abattant douche et le raccord d'eau correspondant doivent exclusivement être montés par des installateurs sanitaires dûment formés. L'installation électrique doit uniquement être réalisée par des installateurs électriques qualifiés.

REMARQUE!

Les prescriptions d'installation des sociétés de distribution locales, les normes nationales et les directives basse tension doivent être respectées sans réserve.

REMARQUE !

Ne PAS monter l'abattant douche dans des locaux exposés au gel. La température ambiante ne doit pas être inférieure à 4 °C.

REMARQUE !

Le transfert de la réhausse de l'abattant douche d'un endroit froid à un endroit chaud peut entraîner l'apparition de condensation.

> Laisser l'appareil éteint quelques heures.

Instructions de sécurité

⚠ DANGER !

Danger de mort par électrocution.

> NE PAS démonter les différents composants de l'abattant douche.

Consignes de montage

Avant le montage, lire les fiches techniques de préinstallation. Celles-ci peuvent être téléchargées sur Internet via le site www.duravit.com.

Une vidéo d'installation de l'abattant douche complet est disponible sur pro.duravit.com/mounting.



Utilisez pour cela simplement ce code QR

1 Vérifier les conditions de montage (graphique 1)

> Le montage de la cuvette de WC en céramique avec pré-installation de l'alimentation en eau est décrit dans une notice séparée. S'assurer que les alimentations et la cuvette de WC en céramique ont été installées conformément à la notice et aux instructions.

23 Positionner le support de la télécommande (graphique 23)

> Poursuivre à l'étape 26 pour le montage de la sécurité antivol.
> Pour le montage du support sans sécurité antivol, suivre la notice jusqu'à l'étape 25.

31 Retrait du siège (graphique 31)

> Retirer le siège en cas de besoin, par ex. pour le nettoyage.



重要資訊

關於安裝說明

Duravit 智慧馬桶座當中附有安裝說明，安裝前請務必詳細閱讀。

關鍵字和符號的說明

⚠ 危險！ 導致致命危險或嚴重受傷的高危險

注意！ 避免財產損失



請參閱本章節中的安裝說明



視檢（例如刮痕）

目標讀者群和資格要求

僅限由合格的水電工進行智慧馬桶座和相關水管接頭的安裝。僅限由合格的電工來進行電氣安裝。

注意！
需隨時遵守當地安裝法規，各國專門標準和低壓指令。

注意！
不可將智慧馬桶座安裝在有可能結霜的房間。室內溫度不可低於 4 °C。

注意！
若將沖洗座便器從低溫處移至較溫暖處，可能會發生冷凝現象。
> 將設備關機數小時。

安全說明

⚠ 危險！
觸電致死的危險！
> 不可拆卸獨立智慧馬桶座元件。

安裝說明

安裝前請閱讀安裝前資料表。可在 www.duravit.com 下載。

可在 pro.duravit.com/mounting 取得智慧馬桶座的完整安裝影片。



只需使用二維碼

- 1** 檢查安裝要求（圖 1）
 - > 馬桶安裝和智慧馬桶座供水供電的安裝前在說明中分開描述。確保供水供電和馬桶部分已按照說明和規定安裝。
- 23** 安裝遙控器固定架（圖 23）
 - > 從步驟26繼續，安裝防盜裝置。
 - > 如不欲使用防盜設備，請按照指示進行到步驟 25，安裝固定架。
- 31** 取出座圈（圖 31）
 - > 根據要求取出座圈，如用於清潔。

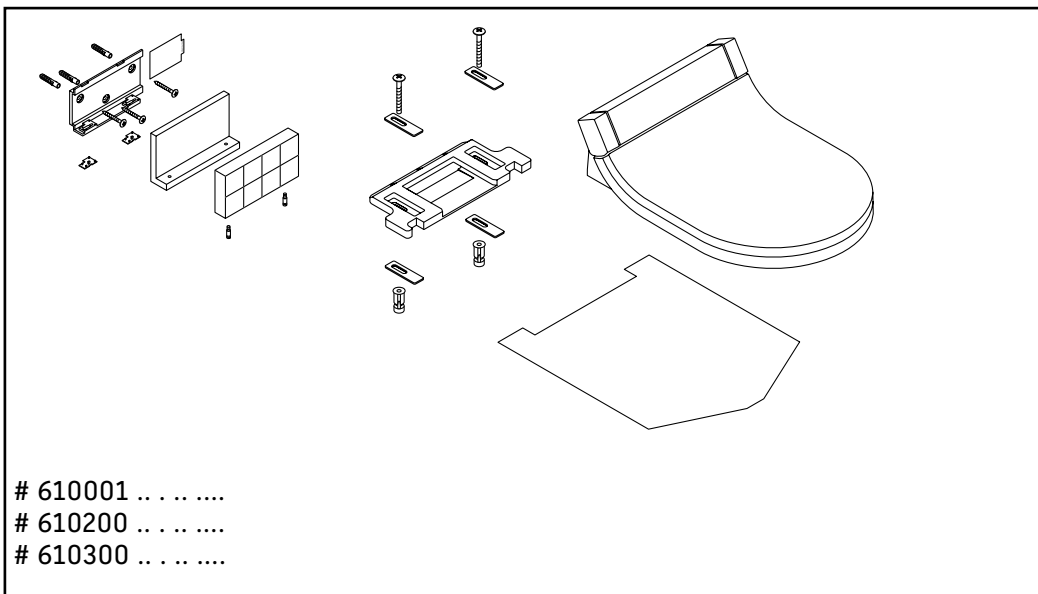

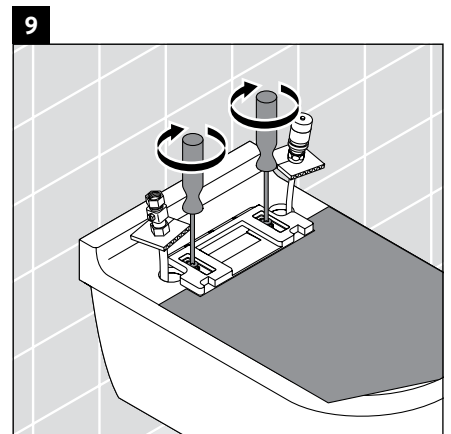
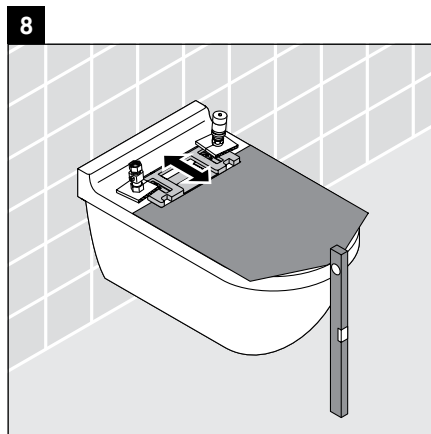
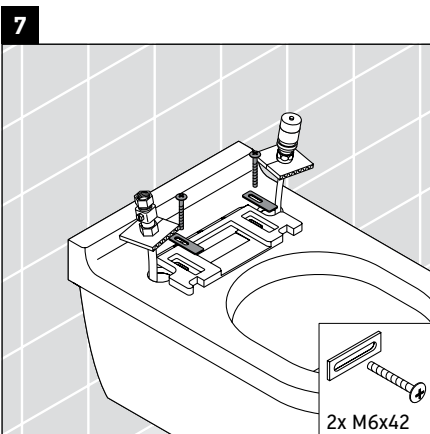
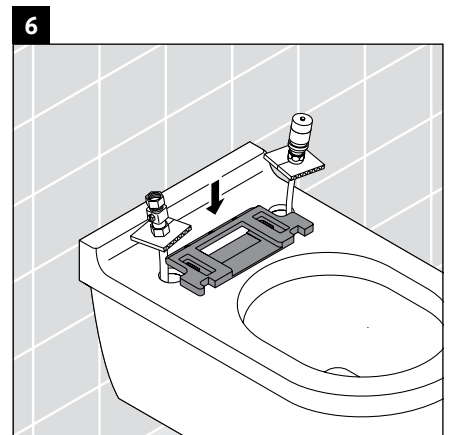
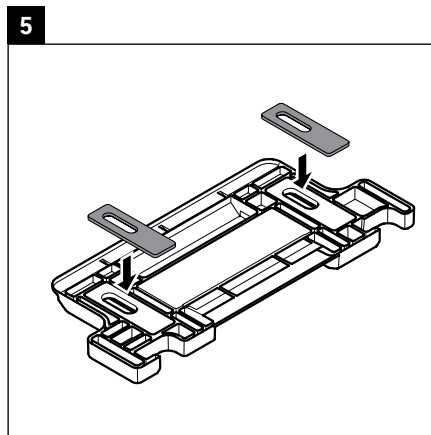
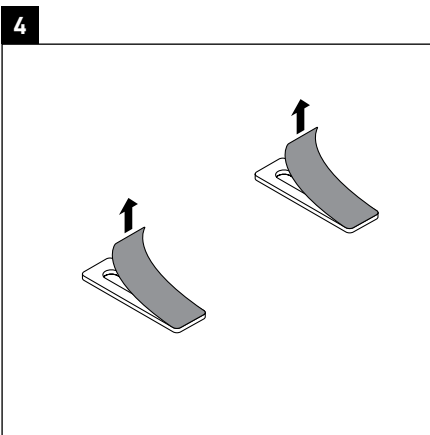
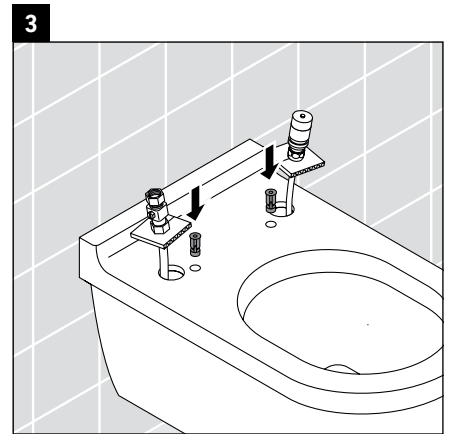
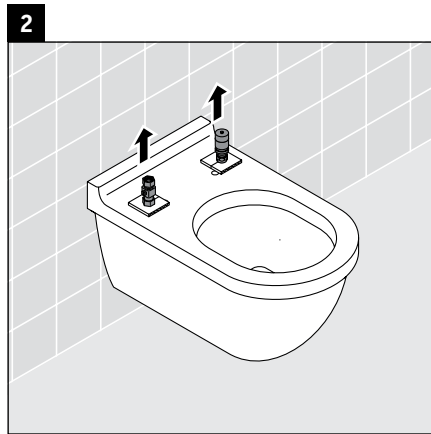
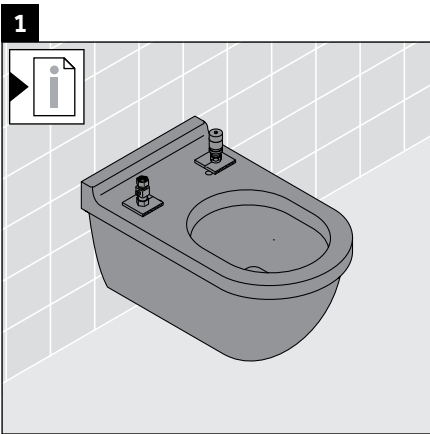

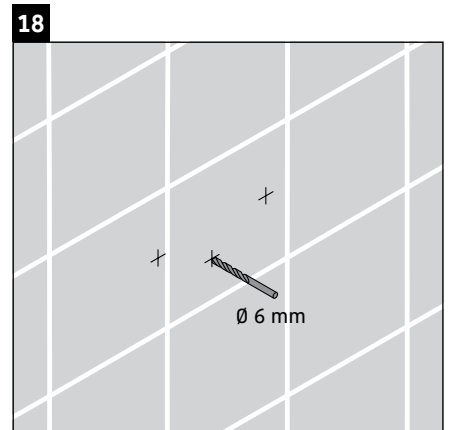
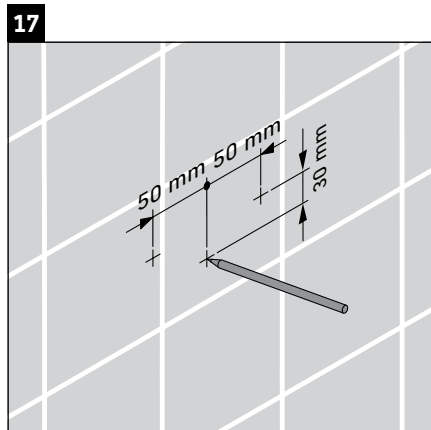
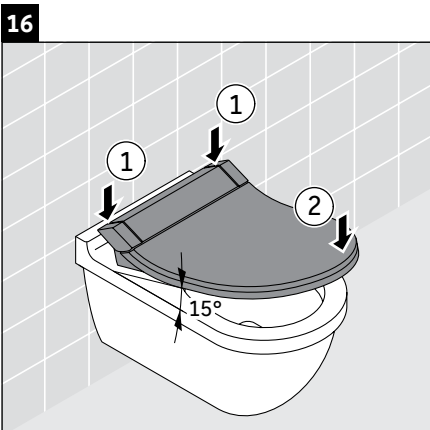
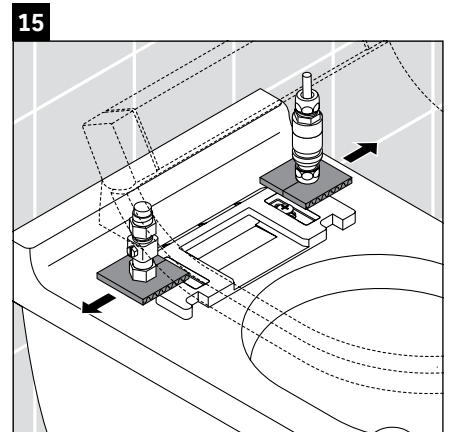
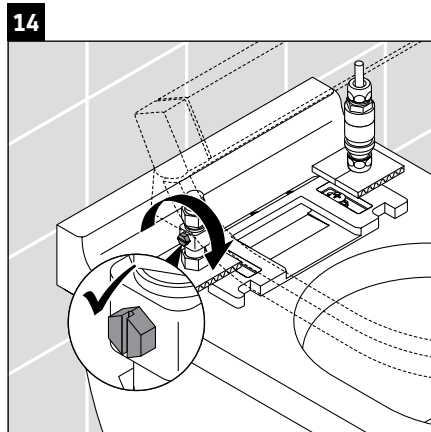
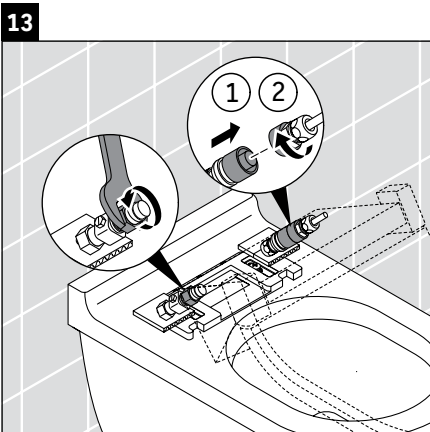
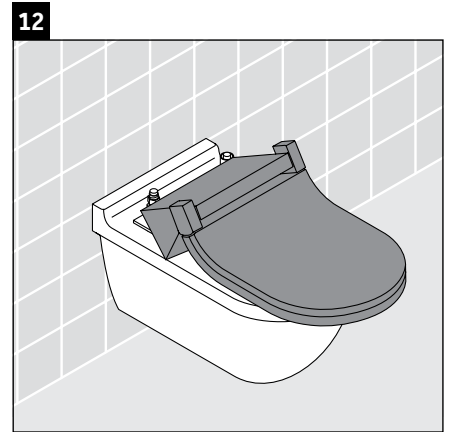
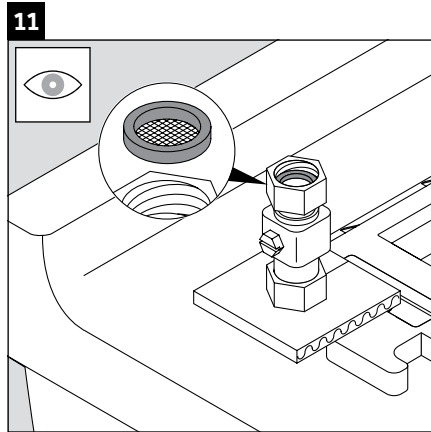
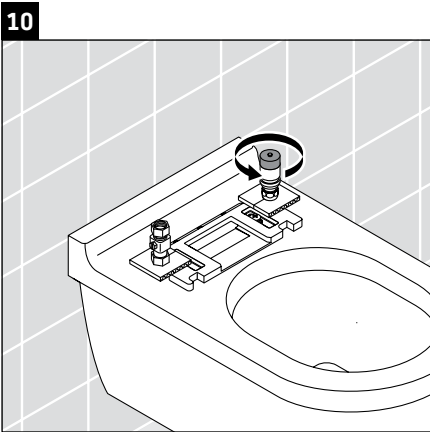

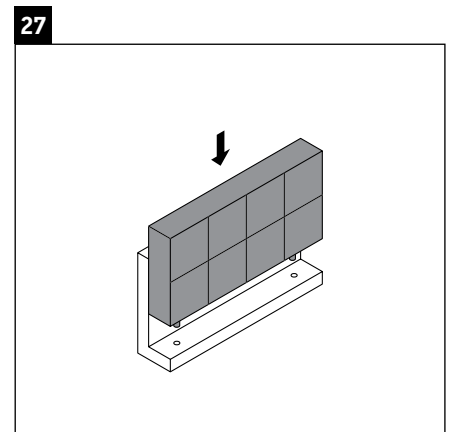
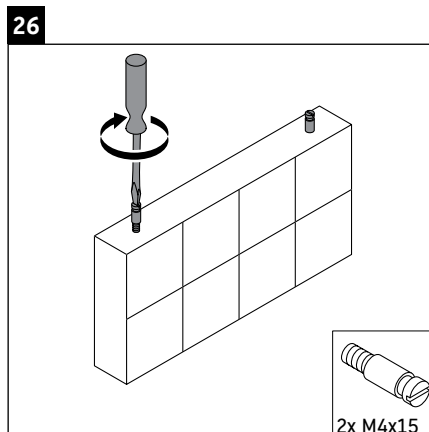
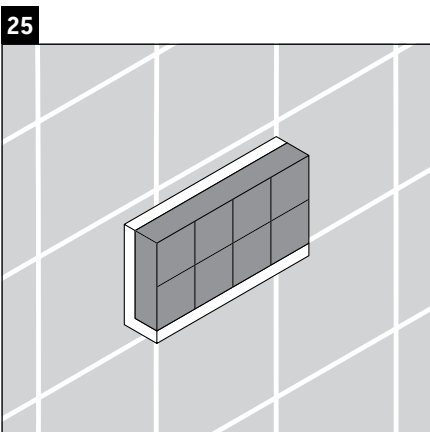
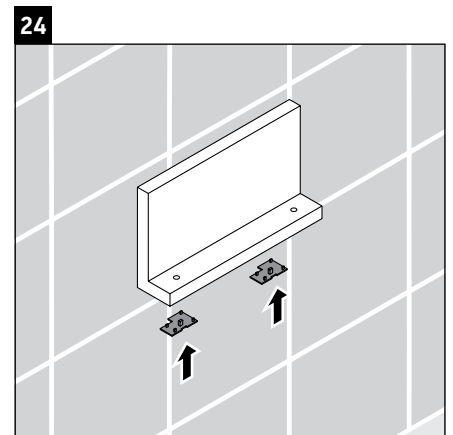
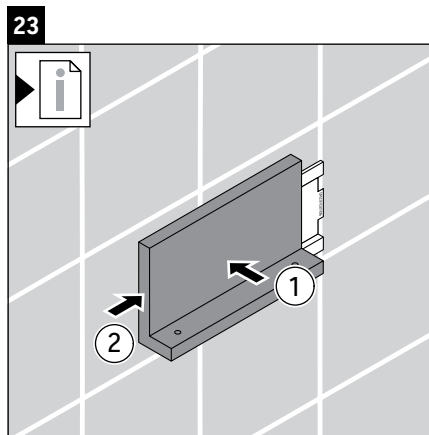
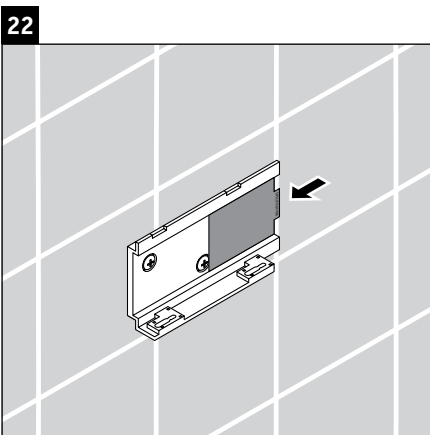
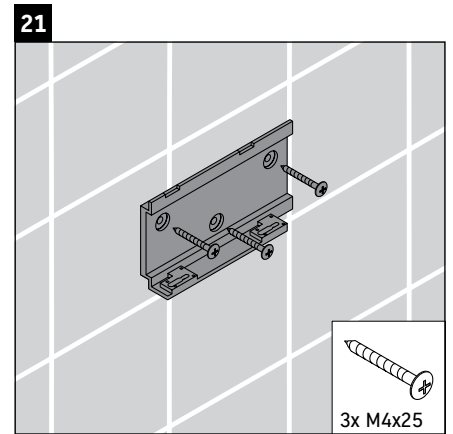
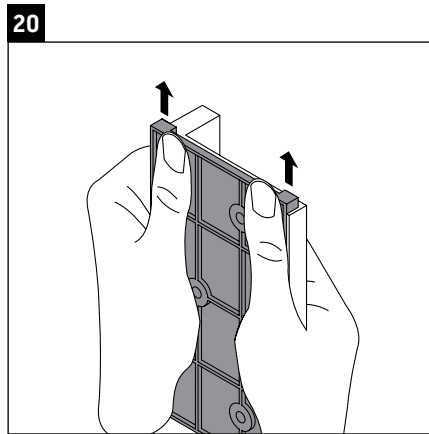
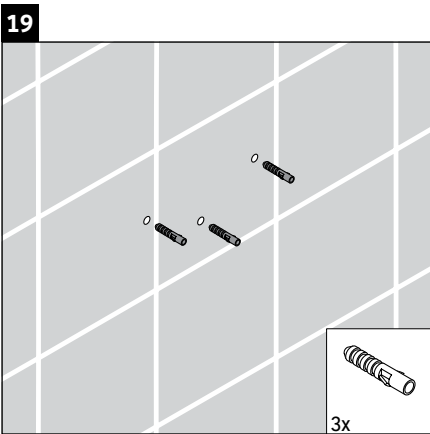

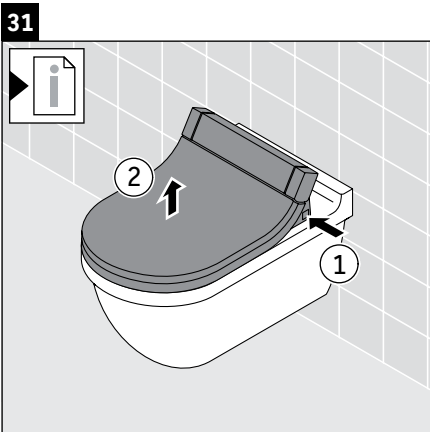
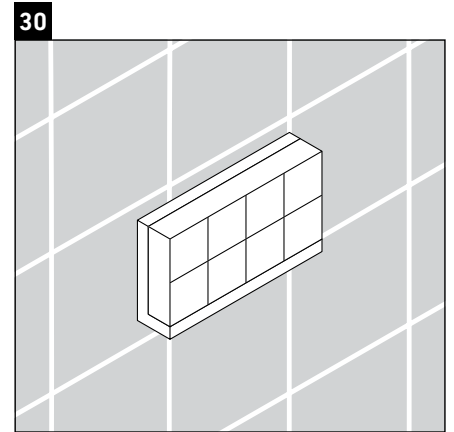
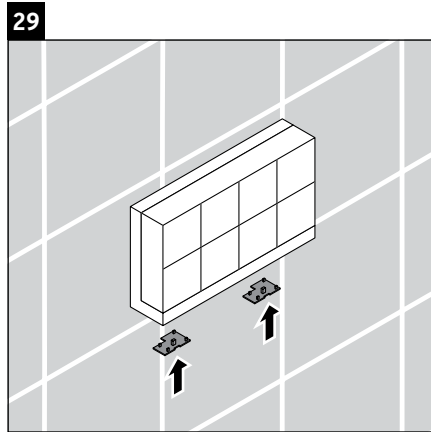
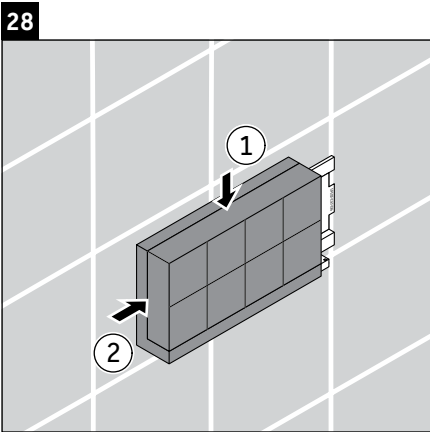

Duravit AG
P.O. Box 240
Werderstr. 36
78132 Hornberg
Germany
Phone +49 78 33 70 0
Fax +49 78 33 70 289
info@duravit.com
www.duravit.com

