



6,000 BTU/H WALL MOUNTED IDU

SUBMITTAL COVER SHEET

PROJECT NAME _____

LOCATION _____

ARCHITECT _____

ENGINEER _____

CONTRACTOR _____

REFERENCE _____

SUBMITTED BY _____ DATE _____

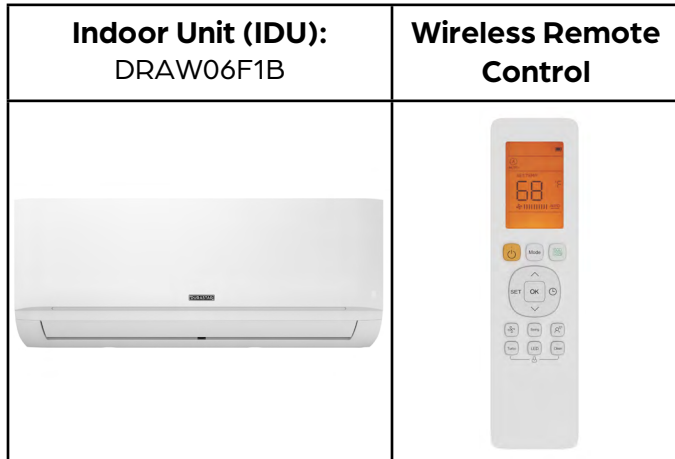

PRODUCT FEATURES

- Up to 100% heating capacity at 0°C
- High efficiency SEER2 rating, up to 23.5
- Wireless Remote Control with "Follow Me" Technology
- Single or Multi-zone compatible
- Sleep Mode
- Turbo Mode
- 24-Hour Timer Feature
- Anti-corrosive fin coating

SPECIFICATIONS		
Cooling Capacity (BTU/hr)	6000	
Heating Capacity (BTU/hr)	7000	
Voltage/Phase/Frequency	208-230V, 1 Phase, 60 Hz	
Voltage Range	187-253V	
Indoor Unit Air Flow (CFM)	Low	176
	Medium	247
	High	294
Drain Port O.D.	Ø5/8" (Ø16mm)	
Recommended Breaker (Amps)	15	
Sound Pressure (dB(A))	Low	20.5
	Medium	33.0
	High	38.5
Refrigerant	R-410A	

LINE SET REQUIREMENTS	
Connection Type	Flare
Liquid	Ø1/4" (Ø6.35mm)
Gas	Ø3/8" (Ø9.52mm)

DIMENSIONS AND WEIGHT		
Unit Dimensions	Width	28-11/16"
	Depth	7-7/8"
	Height	11-1/2"
Carton Dimensions	Width	31-1/8"
	Depth	10-5/8"
	Height	14-3/4"
Net Weight	17.6 lbs.	
Gross Weight	22.5 lbs.	





6,000 BTU/H WALL MOUNTED IDU

IDU DIMENSIONS - DRAW06F1B

Unit Dimensions

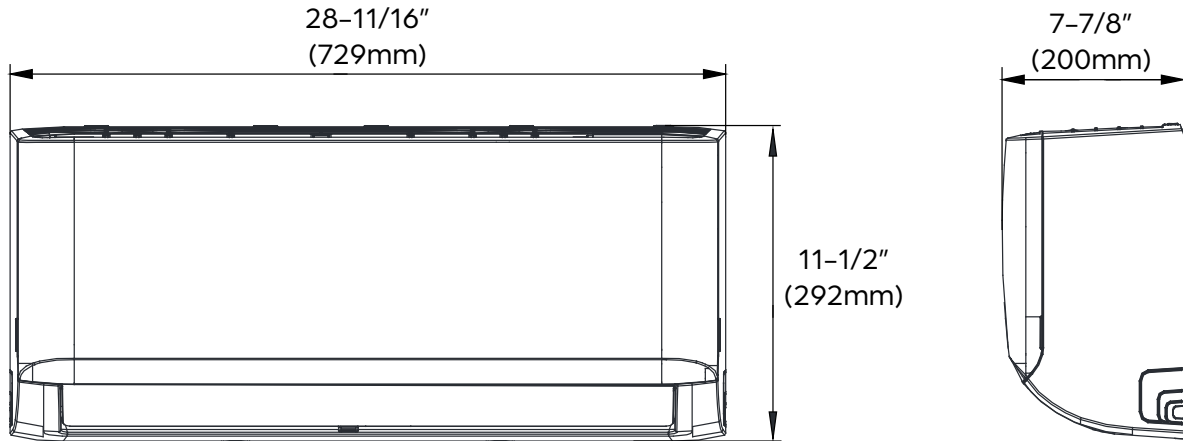

Mounting Plate Dimensions

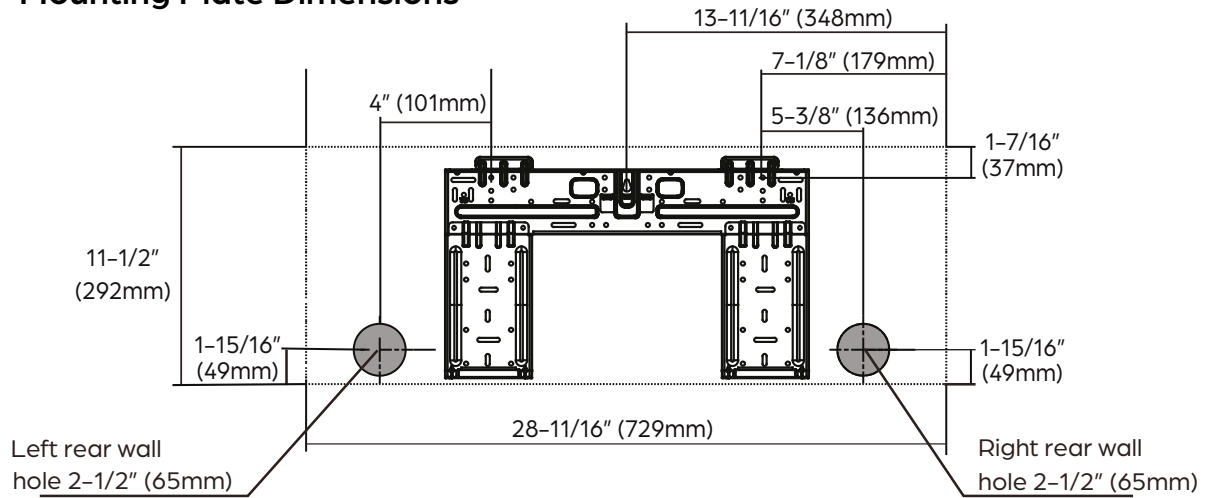

Clearance Distances

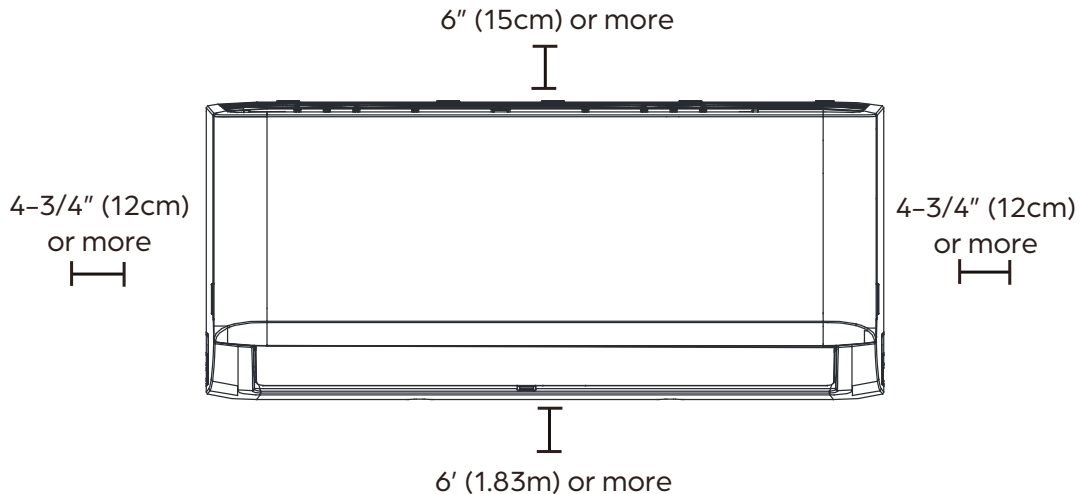



24,000 BTU/H WALL MOUNTED IDU

SUBMITTAL COVER SHEET

PROJECT NAME _____

LOCATION _____

ARCHITECT _____

ENGINEER _____

CONTRACTOR _____

REFERENCE _____

SUBMITTED BY _____ DATE _____

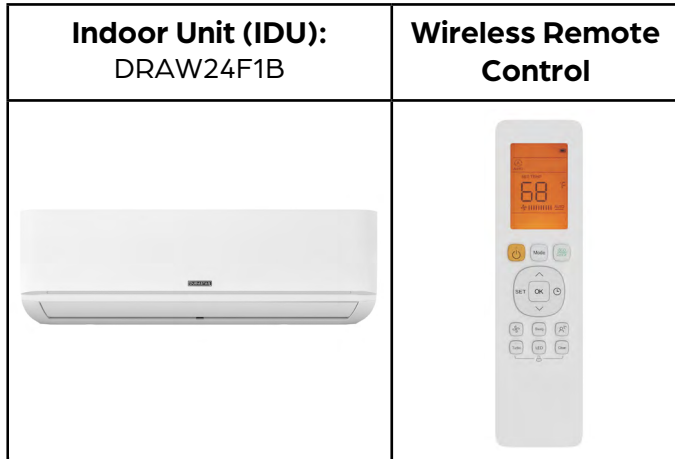

PRODUCT FEATURES

- Wireless Remote Control with "Follow Me" Technology
- Single or Multizone compatible
- High efficiency SEER rating, up to 22.2
- Sleep Mode
- Turbo Mode
- 24-Hour Timer Feature
- Anti-corrosive fin coating

SPECIFICATIONS		
Cooling Capacity (BTU/hr)	24000	
Heating Capacity (BTU/hr)	26000	
Voltage/Phase/Frequency	208-230V, 1 Phase, 60 Hz	
Voltage Range	187-253V	
Indoor Unit Air Flow (CFM)	Low	382
	Medium	459
	High	601
Moisture Removal (Pints/day)	131.52	
Drain Port O.D.	Ø5/8" (Ø16mm)	
Recommended Breaker (Amps)	15	
Sound Pressure (dB(A))	Low	28
	Medium	40
	High	48
Refrigerant	R410A	

LINE SET REQUIREMENTS	
Connection Type	Flare
Liquid	Ø3/8" (Ø9.52mm)
Gas	Ø5/8" (Ø16mm)

DIMENSIONS AND WEIGHT		
Unit Dimensions	Width	42 5/8"
	Depth	9 3/16"
	Height	13 1/4"
Carton Dimensions	Width	45 1/2"
	Depth	12 3/8"
	Height	16 5/16"
Net Weight	30 lbs.	
Gross Weight	39.1 lbs.	





24,000 BTU/H WALL MOUNTED IDU

IDU DIMENSIONS - DRAW24F1B

Unit Dimensions

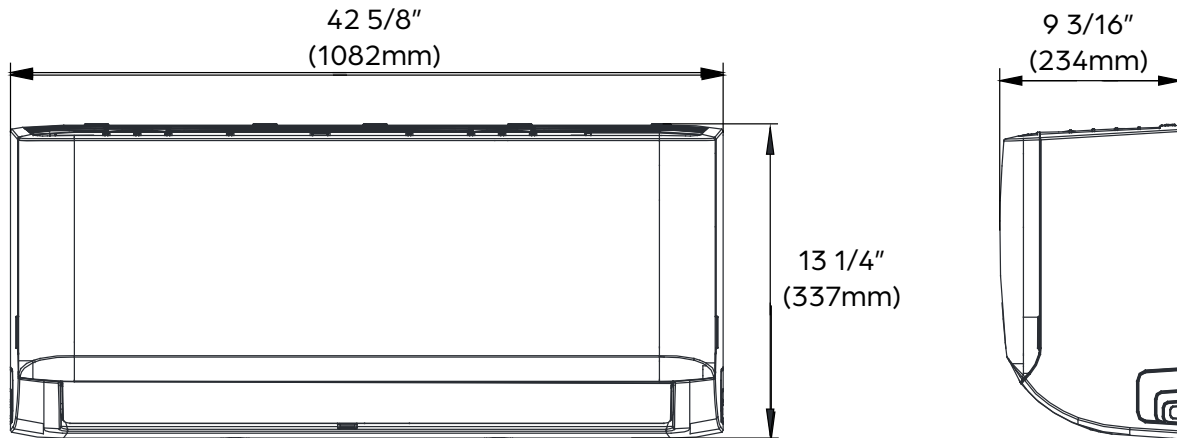

Mounting Plate Dimensions

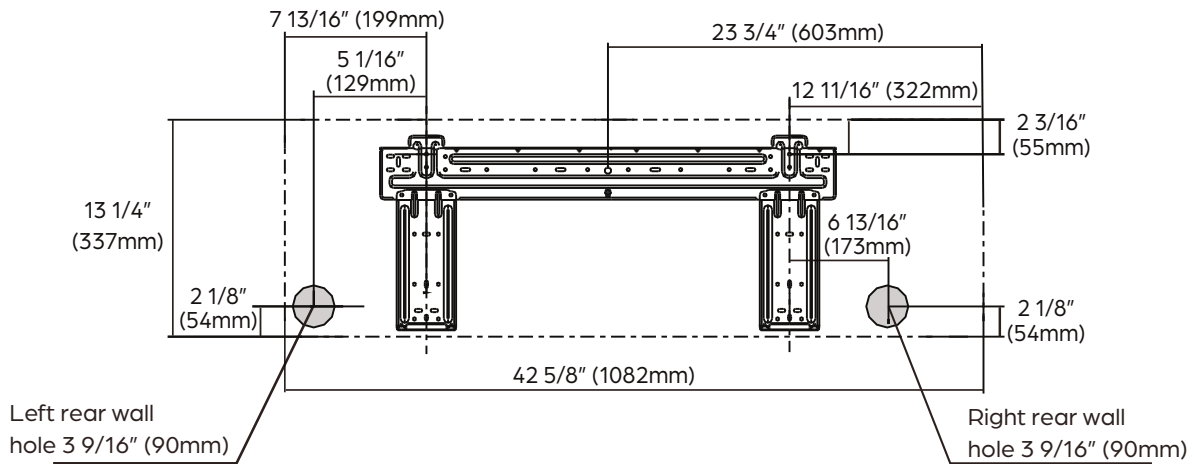

Clearance Distances

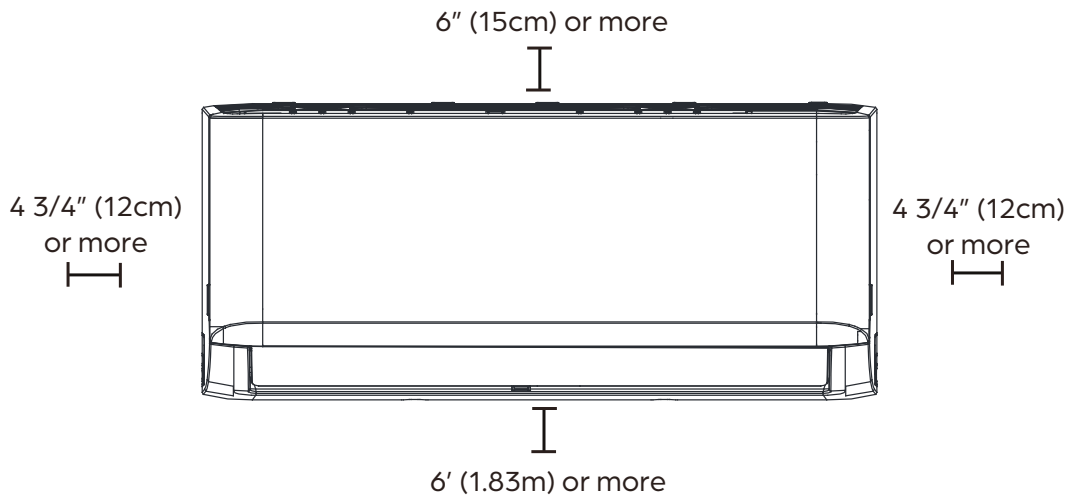



SIRIUS HEAT™

55,000 BTU/H SIRIUS HEAT MULTI-ZONE HEAT PUMP

SUBMITTAL COVER SHEET

PROJECT NAME _____

LOCATION _____

ARCHITECT _____

ENGINEER _____

CONTRACTOR _____

REFERENCE _____

SUBMITTED BY _____ DATE _____

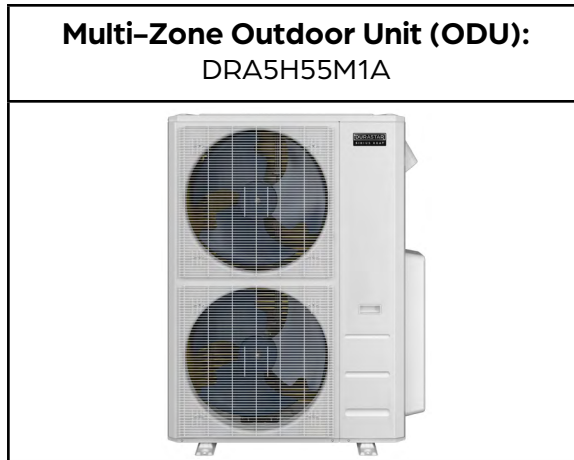

PRODUCT FEATURES

- High heating capacity at 0°F
- Variable speed inverter compressor
- Low ambient heating down to -22°F
- Low ambient cooling down to 5°F
- Quiet operation
- Included base pan heater
- Auto restart
- Anti-corrosive coil coating
- Port adaptors included

SYSTEM DATA	
Refrigerant Type	R-410A
Refrigerant Charge (oz.)	162.26
Design Pressure (PSIG)	550/340
Outdoor Coil Coating	Golden Fin Coating

CAPACITIES		DUCTLESS	MIXED	DUCTED
Cooling (BTU/hr)	Rated ¹	55000	55000	55000
	at 5°F ³	43410	40660	37910
	Minimum	11600	15500	19400
	Maximum	56900	57000	57100
Heating (BTU/hr)	Rated ²	55000	55000	55000
	at 5°F ⁴	45500	45750	46000
	Minimum	33000	48500	15500
	Maximum	63000	62300	61600
Nominal ODU Capacity ⁵		55000		

EFFICIENCY DATA	DUCTLESS	MIXED	DUCTED
SEER2	20.00	19.40	18.80
EER2	10.50	10.50	10.50
HSPF2	9.50	9.40	9.30
SEER	19.00	19.00	19.00
EER	10.50	10.50	10.50
HSPF	10.80	10.90	11.00
COP at 47°F	3.20	3.20	3.20
COP at 5°F	1.80	1.85	1.90



Specifications are subject to change without notice.
 © 2023 Ferguson Enterprises LLC
 www.durastar.com



55,000 BTU/H SIRIUS HEAT MULTI-ZONE HEAT PUMP

SPECIFICATIONS - DRA5H55M1A

SIRIUS HEAT™

LINE SET REQUIREMENTS	
Connection Type	Flare
Liquid	5 x Ø1/4" (Ø6.35mm)
Gas	3 x Ø3/8" (Ø9.52mm) 2 x Ø1/2" (Ø12.7mm)
Refrigeration Adaptors Included	3 x 3/8" -- 1/2" 2 x 1/2" -- 3/8" 2 x 1/4" -- 3/8" 2 x 1/2" -- 5/8"
Minimum Indoor Units Connected	2
Pre-Charge Length	123'
Maximum Length (combined IDUs)	263'
Maximum Length (per IDU)	115'
Minimum Length (per IDU)	10'
Max. Height Differential between IDU and ODU	49'
Max. Height Differential between IDUs	33'
Additional Refrigerant for Ø1/4" Liquid Pipe (oz./ft)	0.161
Additional Refrigerant for Ø3/8" Liquid Pipe (oz./ft)	0.322

OUTDOOR UNIT DATA		
Unit Dimensions	Width	37-1/2"
	Depth	16-5/16"
	Height	52-1/2"
Carton Dimensions	Width	43-1/8"
	Depth	19-1/2"
	Height	58-1/4"
Net Weight	233 lbs.	
Gross Weight	266 lbs.	
Cooling Operating Temperature	5°F - 122°F	
Heating Operating Temperature	-22°F - 75°F	
Airflow (CFM)	4500	
Sound Pressure (dB(A))	61	
Fan Speed (r/min)	Low	750
	Medium	800
	Medium	850
	High	900
Fan Motor Current Type	DC	

ELECTRICAL DATA	DUCTLESS		DUCTED	
	Voltage/Phase/Frequency	208-230V, 1 Phase, 60 Hz		
Voltage Range	187-253V			
Recommended Breaker (Amps)	60			
Minimum Circuit Ampacity (Amps)	40			
Communication Wire Size	14*4 AWG Stranded			
Rated Current - Cooling (Amps) ¹	23.5		23.5	
Rated Current - Heating (Amps) ²	22.5		22.5	

COMPRESSOR	
Type	DC Inverter Twin Cylinder Rotary
Oil Type	VG74
Oil Charge (oz.)	49 (1460mL)

¹ AHRI Rated at 95°F (A Full).

² AHRI Rated at 47°F (H1 Full).

³ Sensible Capacity: Indoor 80°F DB, 67°F WB // Outdoor 5°F DB, 4°F WB

⁴ AHRI Rated Capacity at 5°F (H42)

⁵ If the total indoor unit load exceeds the nominal capacity of the outdoor unit, the practical output capacity of each indoor unit will be correspondingly reduced. This situation is very evident during heating mode.

Clearances

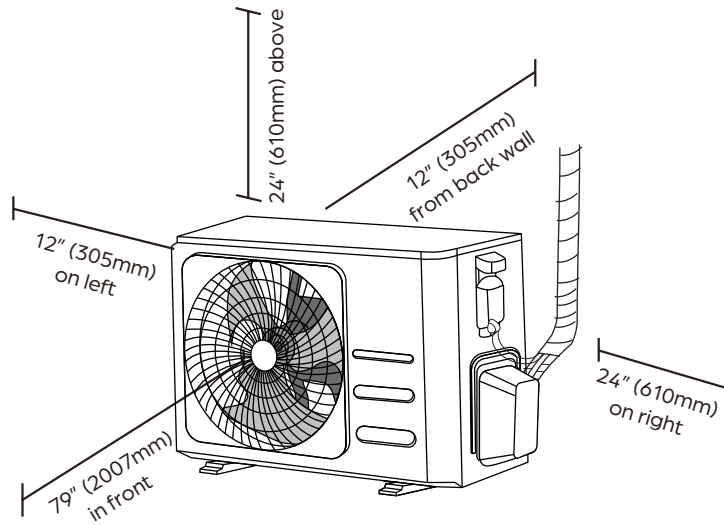

Dimensions

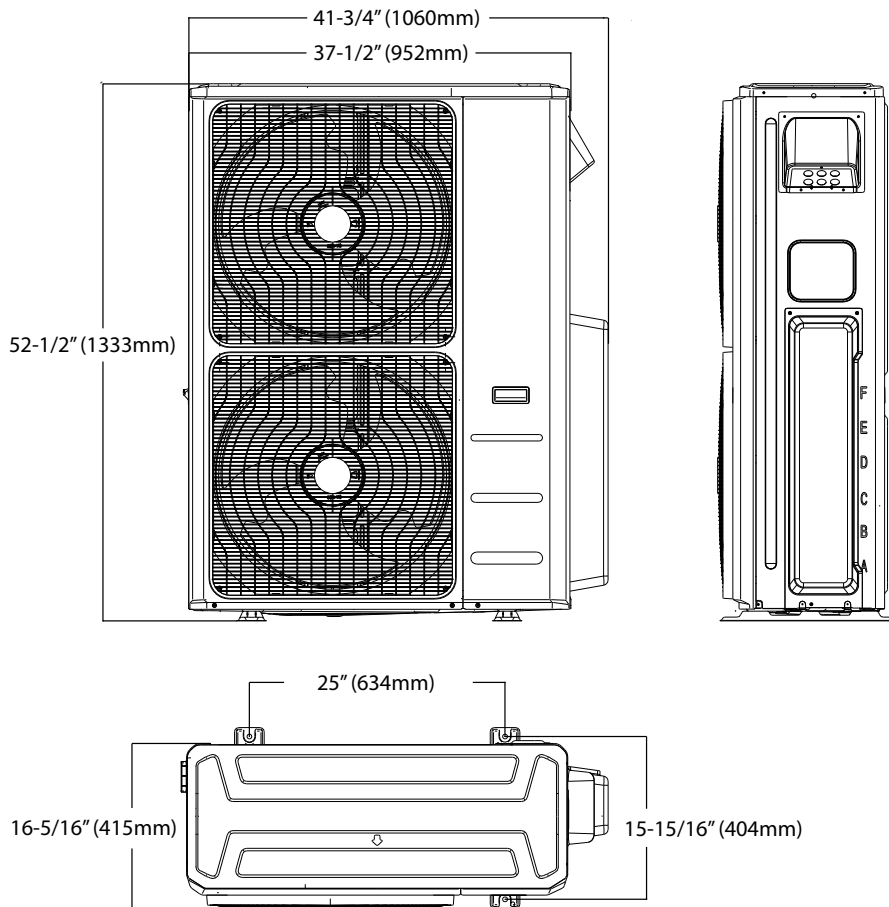

NOTE

- Illustrations in this document are for explanatory purposes. The actual shape of your mini-split equipment may vary slightly.