



18,000 BTU/H FLOOR/CEILING IDU

SUBMITTAL COVER SHEET

PROJECT NAME _____

LOCATION _____

ARCHITECT _____

ENGINEER _____

CONTRACTOR _____

REFERENCE _____

SUBMITTED BY _____ DATE _____

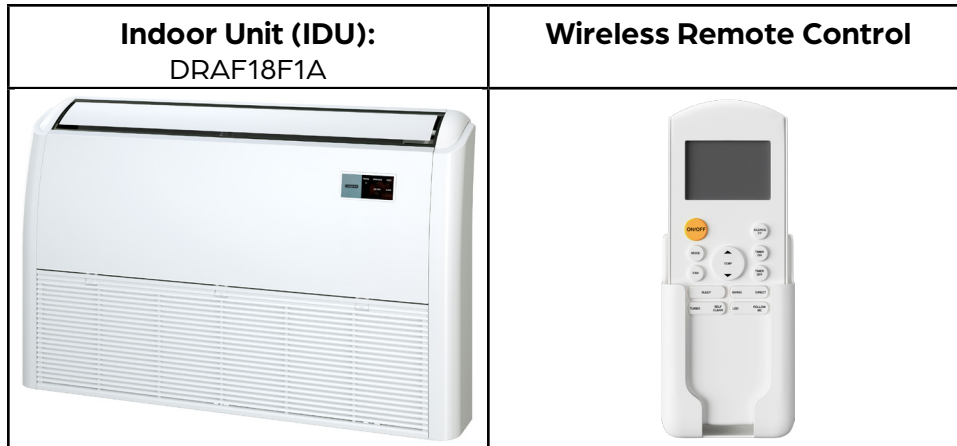

CAPACITIES		
Cooling Capacity (BTU/hr)	Rated	18000
Heating Capacity (BTU/hr)	Rated	18000

ELECTRICAL DATA	
Voltage/Phase/Frequency	208-230V, 1 Phase, 60 Hz

LINE SET REQUIREMENTS	
Connection Type	Flare
Liquid	Ø1/4" (Ø6.35mm)
Gas	Ø1/2" (Ø12.7mm)
Drain Port O.D. / Drain Hose I.D.	Ø1" (Ø25mm)

INDOOR UNIT FAN DATA		
Air Flow (CFM)	Low	465
	Medium	521
	High	578
Type	DC	
RLA	1.5	
Sound Pressure (dB(A))	Low	39
	Medium	44
	High	47

INDOOR UNIT DIMENSIONS		
Unit Dimensions	Width	42 1/16"
	Depth	9 1/4"
	Height	26 9/16"
Carton Dimensions	Width	45 1/16"
	Depth	12 1/2"
	Height	29 3/4"
Net Weight	57.1 lbs.	
Gross Weight	68.3 lbs.	

PRODUCT FEATURES

- Wireless Remote Control with "Follow Me" Technology
- Auto Restart
- Auto Changeover
- 24-hour Timer
- Self Clean Function



Specifications are subject to change without notice.

© 2021 Ferguson Enterprises LLC
www.durastar.com



18,000 BTU/H FLOOR/CEILING IDU

DIMENSIONS - DRAF18F1A

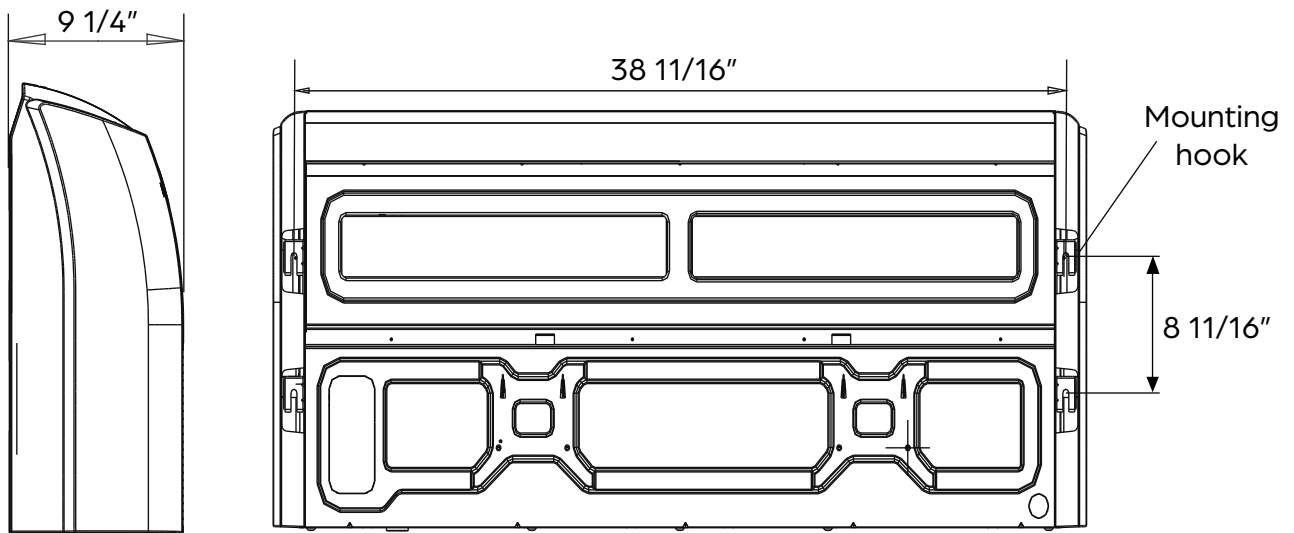
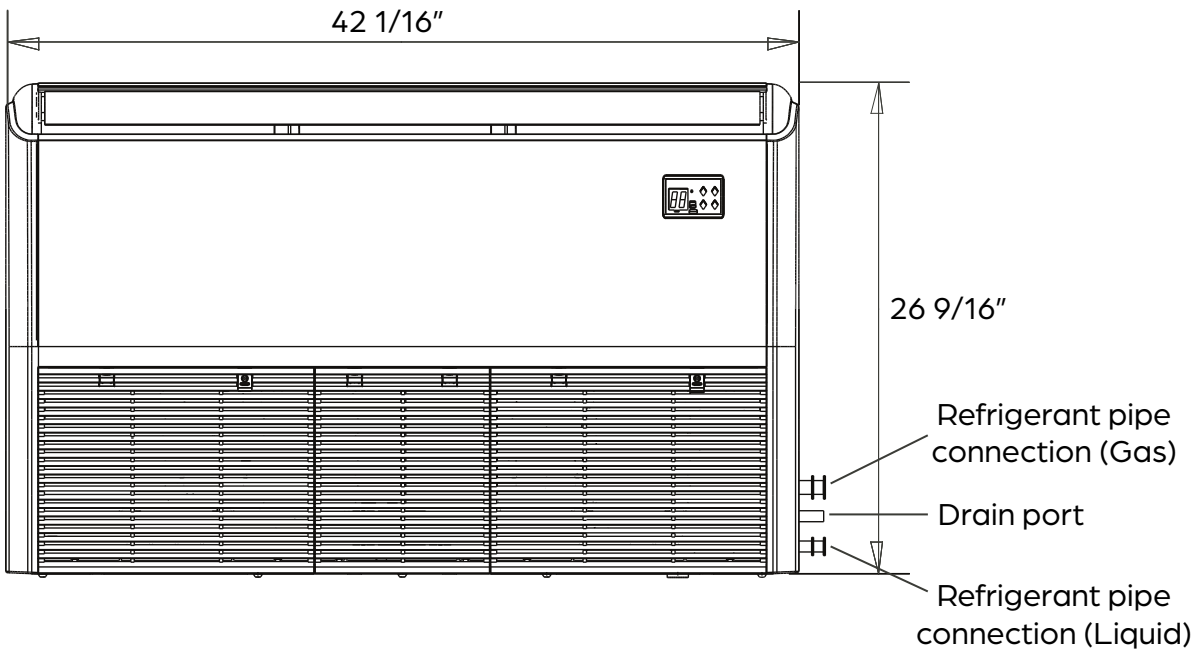



SIRIUS HEAT™

36,000 BTU/H SIRIUS HEAT MULTI-ZONE HEAT PUMP

SUBMITTAL COVER SHEET

PROJECT NAME _____

LOCATION _____

ARCHITECT _____

ENGINEER _____

CONTRACTOR _____

REFERENCE _____

SUBMITTED BY _____ DATE _____



PRODUCT FEATURES

- High heating capacity at 0°F
- Variable speed inverter compressor
- Low ambient heating down to -22°F
- Low ambient cooling down to 5°F
- Quiet operation
- Included base pan heater
- Auto restart
- Anti-corrosive coil coating
- Port adaptors included

SYSTEM DATA	
Refrigerant Type	R-410A
Refrigerant Charge (oz.)	162
Design Pressure (PSIG)	550/340
Outdoor Coil Coating	Golden Fin Coating

CAPACITIES		DUCTLESS	MIXED	DUCTED
Cooling (BTU/hr)	Rated ¹	36000	36000	36000
	at 5°F ³	29900	29550	29200
	Minimum	15600	16500	17400
	Maximum	41900	42950	44000
Heating (BTU/hr)	Rated ²	36000	36500	37000
	at 5°F ⁴	36000	34500	33000
	Minimum	20000	13650	13300
	Maximum	50300	48650	47000
Nominal ODU Capacity ⁵		36000		

EFFICIENCY DATA	DUCTLESS	MIXED	DUCTED
SEER2	20.00	19.50	19.00
EER2	12.50	12.10	11.70
HSPF2	9.70	9.85	10.00
SEER	20.00	19.50	19.00
EER	12.50	11.90	11.30
HSPF	10.80	10.90	11.00
COP at 47 °F	3.52	3.63	3.74
COP at 5 °F	1.90	1.80	1.70



Specifications are subject to change without notice.
 © 2023 Ferguson Enterprises LLC
 www.durastar.com



SIRIUS HEAT™

36,000 BTU/H SIRIUS HEAT MULTI-ZONE HEAT PUMP

SPECIFICATIONS - DRA4H36M1A

LINE SET REQUIREMENTS	
Connection Type	Flare
Liquid	4 x Ø1/4" (Ø6.35mm)
Gas	3 x Ø3/8" (Ø9.52mm) 1 x Ø1/2" (Ø12.7mm)
Refrigeration Adaptors Included	3 x 3/8" -- 1/2" 1 x 1/2" -- 3/8" 1 x 1/4" -- 3/8" 1 x 1/2" -- 5/8"
Minimum Indoor Units Connected	2
Pre-Charge Length	98'
Maximum Length (combined IDUs)	262'
Maximum Length (per IDU)	115'
Minimum Length (per IDU)	10'
Max. Height Differential between IDU and ODU	49'
Max. Height Differential between IDUs	33'
Additional Refrigerant for Ø1/4" Liquid Pipe (oz./ft)	0.161
Additional Refrigerant for Ø3/8" Liquid Pipe (oz./ft)	0.322

OUTDOOR UNIT DATA		
Unit Dimensions	Width	37-1/2"
	Depth	16-5/16"
	Height	52-1/2"
Carton Dimensions	Width	43-1/8"
	Depth	19-1/2"
	Height	58-1/4"
Net Weight	223 lbs.	
Gross Weight	254 lbs.	
Cooling Operating Temperature	5°F - 122°F	
Heating Operating Temperature	-22°F - 75°F	
Airflow (CFM)	4500	
Sound Pressure (dB(A))	62	
Fan Speed (r/min)	Low	750
	Medium	800
	Medium	850
	High	900
Fan Motor Current Type	DC	

ELECTRICAL DATA	DUCTLESS		DUCTED	
	Voltage/Phase/Frequency	208-230V, 1 Phase, 60 Hz		
Voltage Range	187-253V			
Recommended Breaker (Amps)	60			
Minimum Circuit Ampacity (Amps)	40			
Communication Wire Size	14*4 AWG Stranded			
Rated Current - Cooling (Amps) ¹	13.2			14.2
Rated Current - Heating (Amps) ²	13.7			12.9

COMPRESSOR	
Type	DC Inverter Twin Cylinder Rotary
Oil Type	VG74
Oil Charge (oz.)	47 (1400 mL)

¹ AHRI Rated at 95°F (AFull).

² AHRI Rated at 47°F (H1Full).

³ Sensible Capacity: Indoor 80°F DB, 67°F WB // Outdoor 5°F DB, 4°F WB

⁴ AHRI Rated Capacity at 5°F (H42)

⁵ If the total indoor unit load exceeds the nominal capacity of the outdoor unit, the practical output capacity of each indoor unit will be correspondingly reduced. This situation is very evident during heating mode.

Clearances

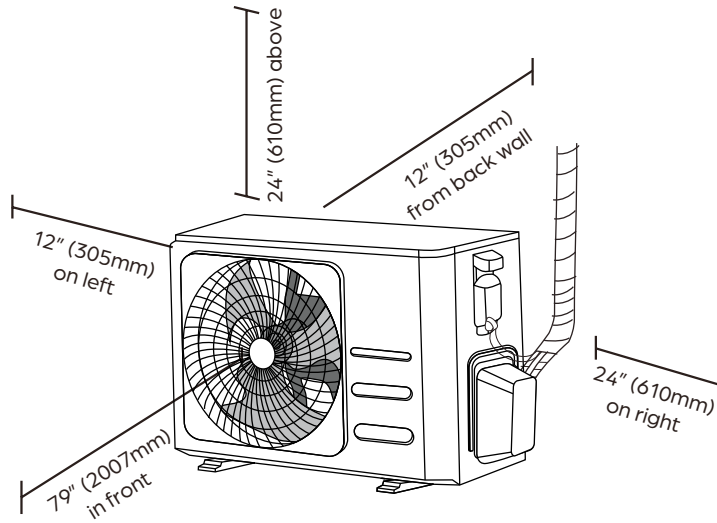

Dimensions

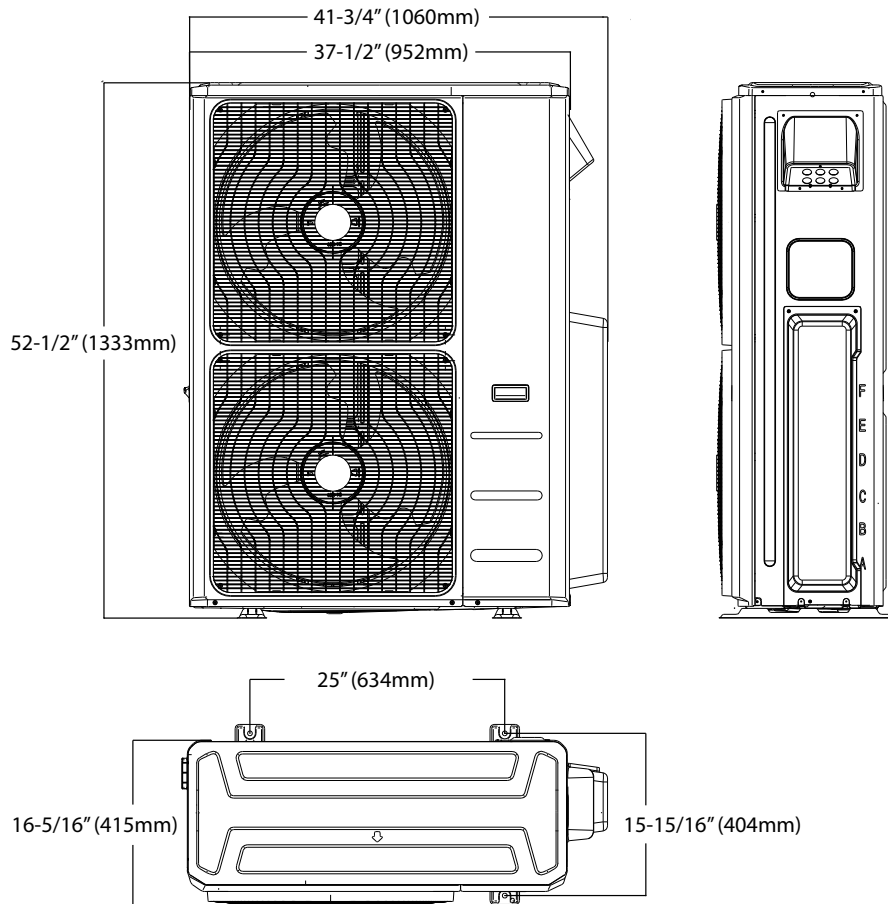

NOTE

- Illustrations in this document are for explanatory purposes. The actual shape of your mini-split equipment may vary slightly.