



6,000 BTU/H WALL MOUNTED IDU

SUBMITTAL COVER SHEET

PROJECT NAME _____

LOCATION _____

ARCHITECT _____

ENGINEER _____

CONTRACTOR _____

REFERENCE _____

SUBMITTED BY _____ DATE _____

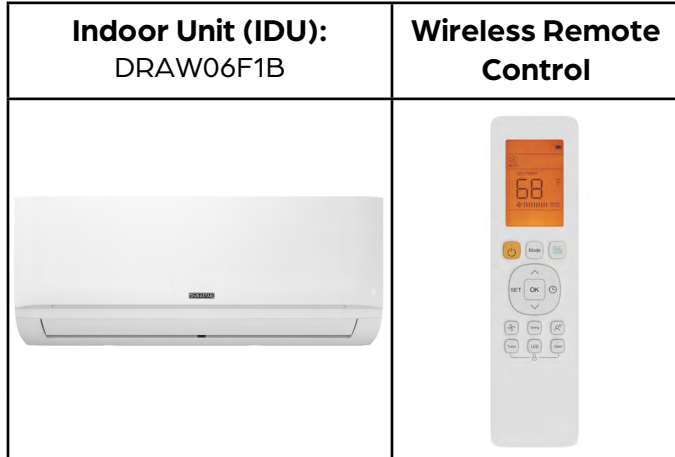

PRODUCT FEATURES

- Up to 100% heating capacity at 0°C
- High efficiency SEER2 rating, up to 23.5
- Wireless Remote Control with "Follow Me" Technology
- Single or Multi-zone compatible
- Sleep Mode
- Turbo Mode
- 24-Hour Timer Feature
- Anti-corrosive fin coating

SPECIFICATIONS		
Cooling Capacity (BTU/hr)	6000	
Heating Capacity (BTU/hr)	7000	
Voltage/Phase/Frequency	208-230V, 1 Phase, 60 Hz	
Voltage Range	187-253V	
Indoor Unit Air Flow (CFM)	Low	176
	Medium	247
	High	294
Drain Port O.D.	Ø5/8" (Ø16mm)	
Recommended Breaker (Amps)	15	
Sound Pressure (dB(A))	Low	20.5
	Medium	33.0
	High	38.5
Refrigerant	R-410A	

LINE SET REQUIREMENTS	
Connection Type	Flare
Liquid	Ø1/4" (Ø6.35mm)
Gas	Ø3/8" (Ø9.52mm)

DIMENSIONS AND WEIGHT		
Unit Dimensions	Width	28-11/16"
	Depth	7-7/8"
	Height	11-1/2"
Carton Dimensions	Width	31-1/8"
	Depth	10-5/8"
	Height	14-3/4"
Net Weight	17.6 lbs.	
Gross Weight	22.5 lbs.	





6,000 BTU/H WALL MOUNTED IDU

IDU DIMENSIONS - DRAW06F1B

Unit Dimensions

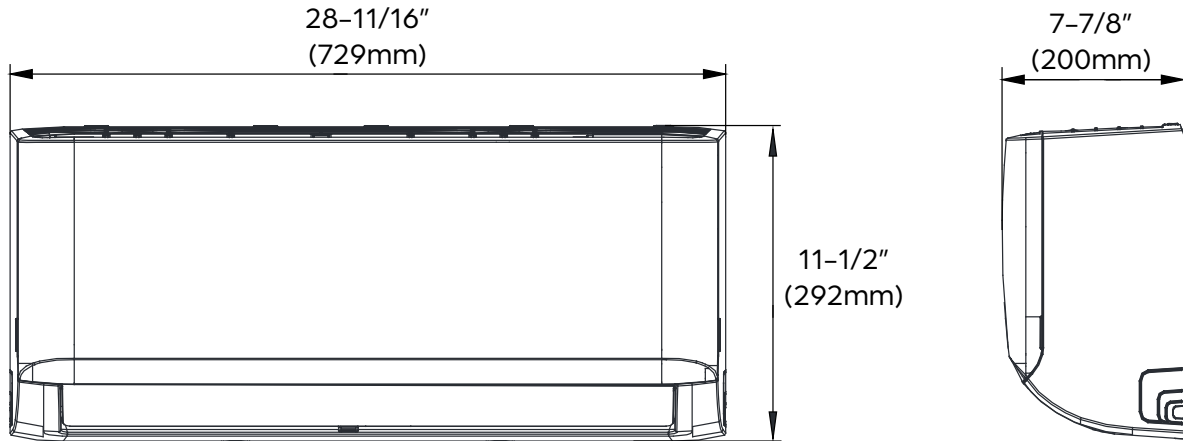

Mounting Plate Dimensions

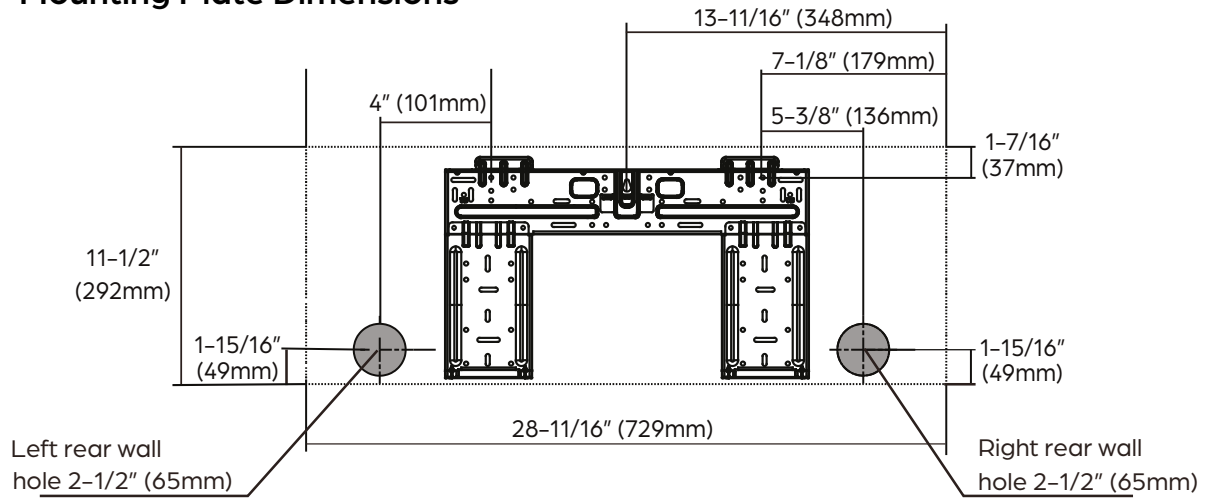

Clearance Distances

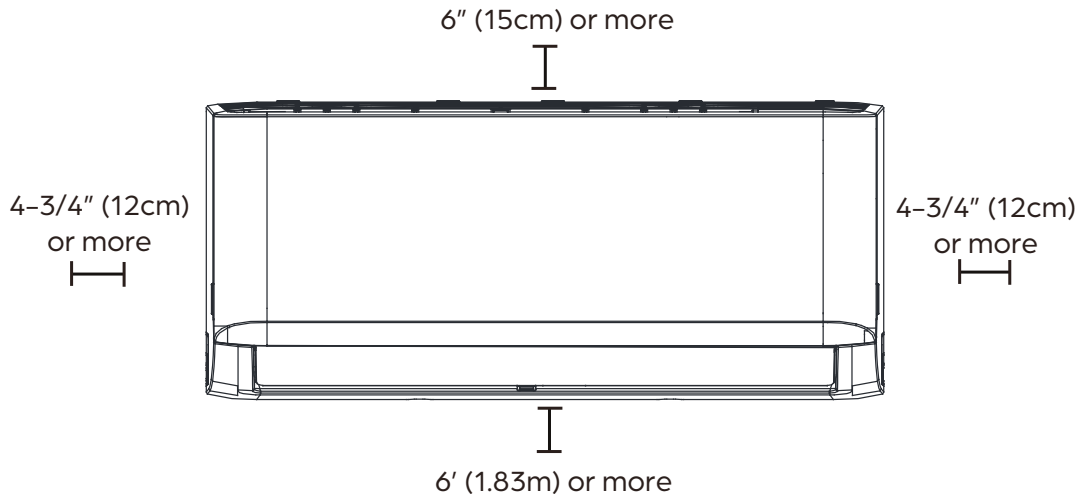



9,000 BTU/H WALL MOUNTED HEAT PUMP SYSTEM

SUBMITTAL COVER SHEET

PROJECT NAME _____

LOCATION _____



ARCHITECT _____

ENGINEER _____

CONTRACTOR _____

REFERENCE _____

SUBMITTED BY _____ DATE _____

Indoor Unit (IDU): DRAW09F1B	Outdoor Unit (ODU): DRA1U09S1B	Wireless Remote Control
		

PRODUCT FEATURES

- Wireless Remote Control with "Follow Me" Technology
- Variable Speed Inverter Compressor
- Auto Restart
- Sleep Mode
- Turbo Mode
- 24-Hour Timer Feature
- Quiet operation
- 46°F Freeze Protection
- Low ambient heating down to -13 °F
- Low ambient cooling down to 5 °F
- Included base pan heater
- Refrigerant leak detection
- Anti-corrosive fin coating

SYSTEM DATA	
Refrigerant Type	R-410A
Refrigerant Charge (oz.)	38.1
Design Pressure (PSIG)	550/340
Indoor/ Outdoor Coil Coating	Golden Fin Coating

EFFICIENCY DATA	
SEER2	24.0
EER2	14.7
HSPF2	11.6
SEER	24.0
EER	14.7
HSPF	12.7
COP at 47 °F	3.66
COP at 5 °F	1.85

CAPACITIES		
Cooling Capacity (BTU/hr)	Rated at 95 °F	9000
	Sensible at 5 °F ³	8010
	Minimum	2500
	Maximum	11900
Heating Capacity (BTU/hr)	Rated at 47 °F	10000
	Rated at 5 °F ⁴	8300
	Minimum	3400
	Maximum	13000



Specifications are subject to change without notice.
 © 2022 Ferguson Enterprises LLC
 www.durastar.com



9,000 BTU/H WALL MOUNTED HEAT PUMP SYSTEM

SPECIFICATIONS

LINE SET REQUIREMENTS	
Connection Type	Flare
Liquid	Ø1/4" (Ø6.35mm)
Gas	Ø3/8" (Ø9.52mm)
Pre-Charge Length	25'
Minimum Length	10'
Maximum Length	82'
Maximum Height Differential	33'
Additional Refrigerant (oz./ft)	0.16

OUTDOOR UNIT		
Unit Dimensions	Width	30 1/8"
	Depth	11 15/16"
	Height	21 7/8"
Carton Dimensions	Width	34 15/16"
	Depth	13 1/4"
	Height	24"
Net Weight	63.7 lbs.	
Gross Weight	69.0 lbs.	
Cooling Operating Temperature	5 °F – 122 °F	
Heating Operating Temperature	-13 °F – 75 °F	
Voltage/Phase/Frequency	208–230V, 1 Phase, 60 Hz	
Voltage Range	187–253V	
Recommended Breaker (Amps)	15	
Minimum Circuit Ampacity (Amps)	13	
Communication Wire Size	14*4 AWG Stranded	
Rated Current – Cooling (Amps) ¹	2.66	
Rated Current – Heating (Amps) ²	3.48	
Sound Pressure (dB(A))	53	

INDOOR UNIT		
Unit Dimensions	Width	31 9/16"
	Depth	7 7/8"
	Height	11 5/8"
Carton Dimensions	Width	34 7/16"
	Depth	11 1/4"
	Height	14 15/16"
Net Weight	19.0 lbs.	
Gross Weight	24.3 lbs.	
Indoor Unit Air Flow (CFM)	Low	153
	Medium	194
	High	291
Moisture Removal (Pints/day)	37.2	
Drain Port O.D.	Ø5/8" (Ø16mm)	
Recommended Breaker (Amps)	15	
Sound Pressure (dB(A))	Low	24
	Medium	34
	High	40

COMPRESSOR	
Type	DC Rotary Inverter
Oil Type	Ester Oil VG74
Oil Charge (oz.)	10.5 (310 ml)

¹ Measured at 95 °F.

² Measured at 47 °F.

³ Sensible Capacity: Indoor 80 °F DB, 67 °F WB // Outdoor 5 °F DB, 4 °F WB

⁴ Maximum Capacity: Indoor 70 °F DB, 67 °F WB // Outdoor 5 °F DB, 4 °F WB



9,000 BTU/H WALL MOUNTED HEAT PUMP SYSTEM

IDU DIMENSIONS - DRAW09F1B

Unit Dimensions

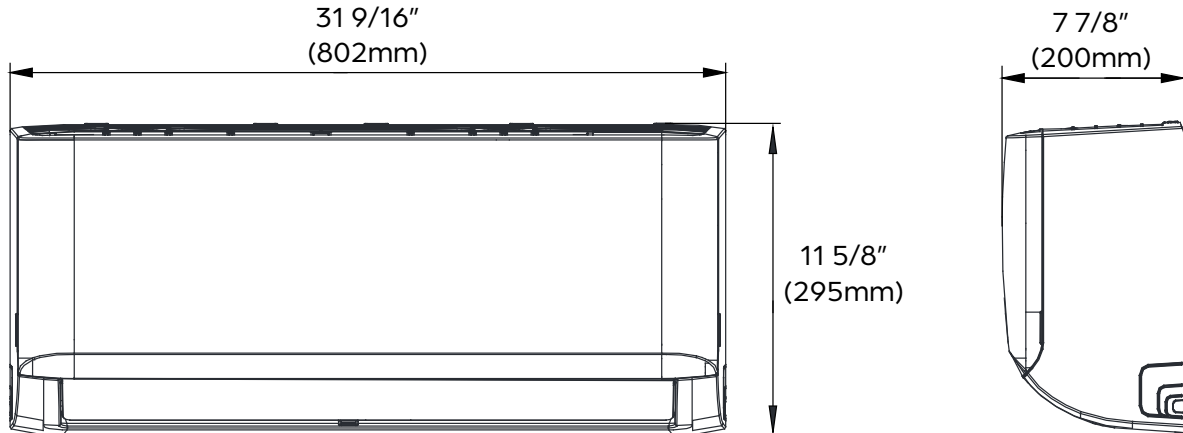

Mounting Plate Dimensions

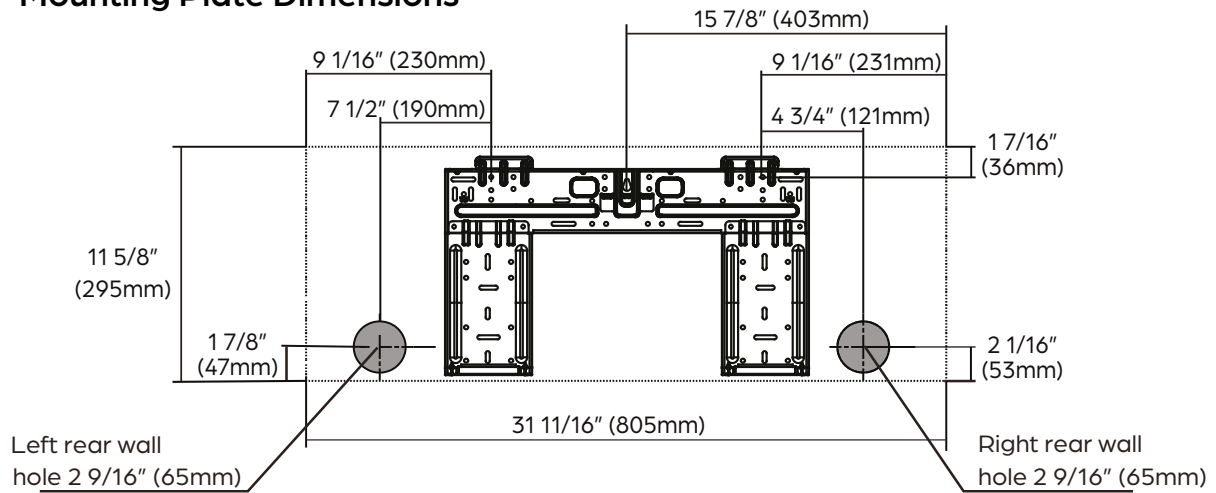

Clearance Distances

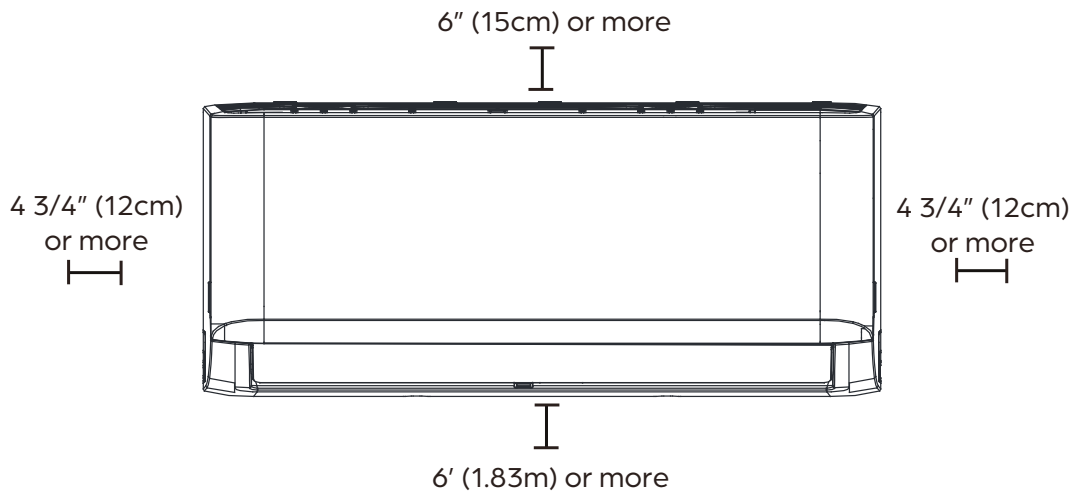



9,000 BTU/H WALL MOUNTED HEAT PUMP SYSTEM

ODU DIMENSIONS - DRA1U09S1B

Clearances

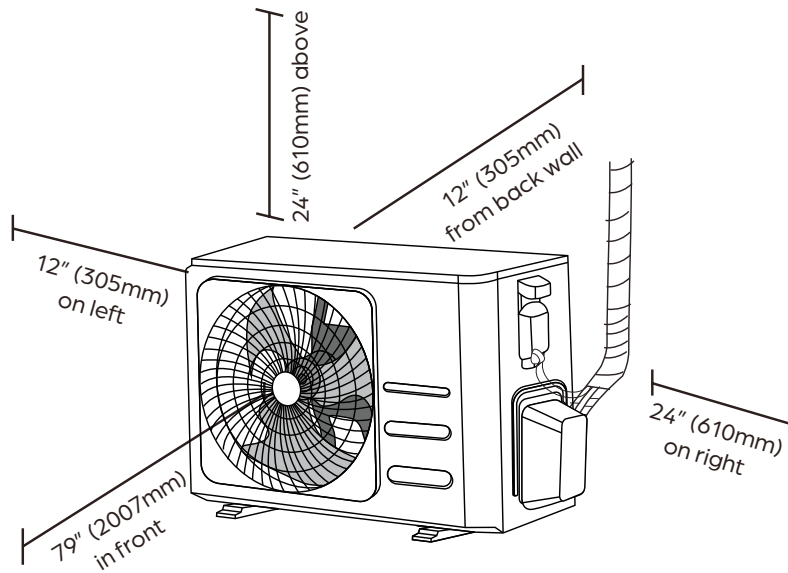

Dimensions

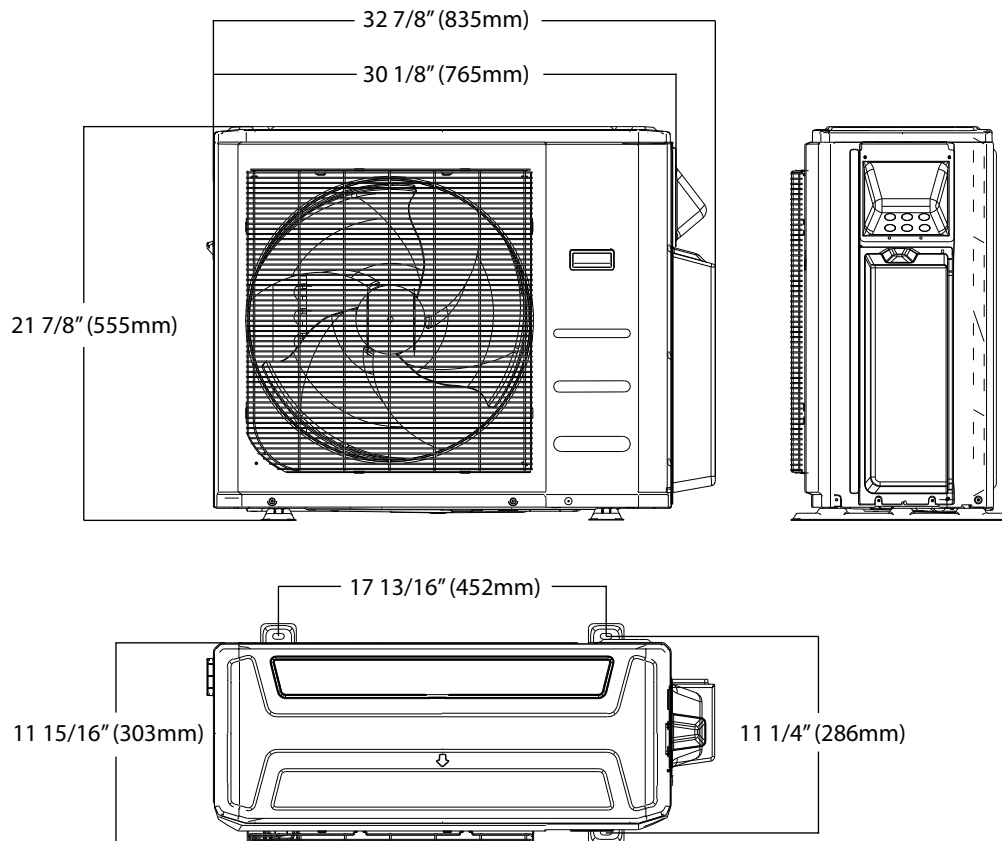

NOTE

Illustrations in this document are for explanatory purposes. The actual shape of your mini-split equipment may vary slightly.