



18,000 BTU/H SLIM DUCTED IDU

SUBMITTAL COVER SHEET

PROJECT NAME _____

LOCATION _____

ARCHITECT _____

ENGINEER _____

CONTRACTOR _____

REFERENCE _____

SUBMITTED BY _____ DATE _____

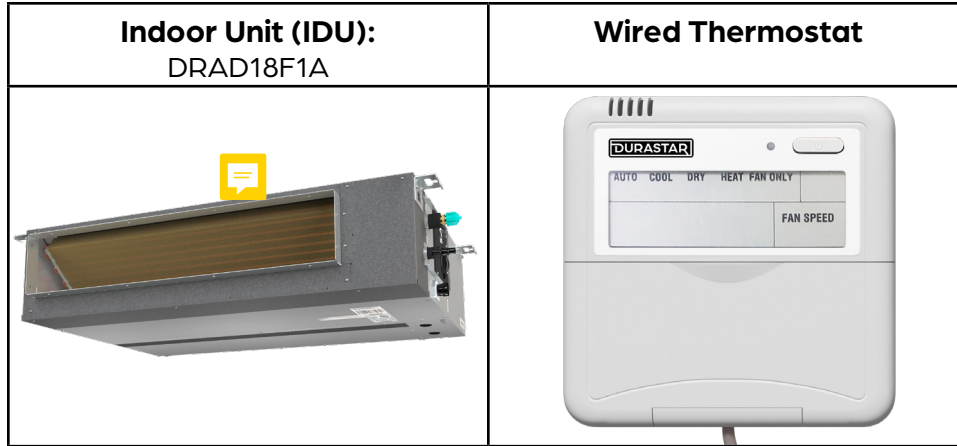

CAPACITIES		
Cooling Capacity (BTU/hr)	Rated	18000
Heating Capacity (BTU/hr)	Rated	18000

ELECTRICAL DATA	
Voltage/Phase/Frequency	208-230V, 1 Phase, 60 Hz

LINE SET REQUIREMENTS	
Connection Type	Flare
Liquid	Ø1/4" (Ø6.35mm)
Gas	Ø1/2" (Ø12.7mm)
Drain Port O.D. / Drain Hose I.D.	Ø1" (Ø25mm)

INDOOR UNIT DIMENSIONS		
Unit Dimensions	Width	34 5/8"
	Depth	26 9/16"
	Height	8 1/4"
Carton Dimensions	Width	42 1/8"
	Depth	28 9/16"
	Height	11"
Net Weight	55.3 lbs.	
Gross Weight	67.0 lbs.	

INDOOR UNIT FAN DATA		
Air Flow (CFM)	Low	371
	Medium	450
	High	530
Type	DC	
RLA	1.2	
Sound Pressure (dB(A))	Low	35
	Medium	37
	High	39
Static Pressure (in wg)	0-0.40	

PRODUCT FEATURES

- Wired Thermostat Included
- Auto Restart
- Auto Changeover
- 24-hour Timer





18,000 BTU/H SLIM DUCTED IDU

DIMENSIONS - DRAD18F1A

Unit and air outlet dimensions

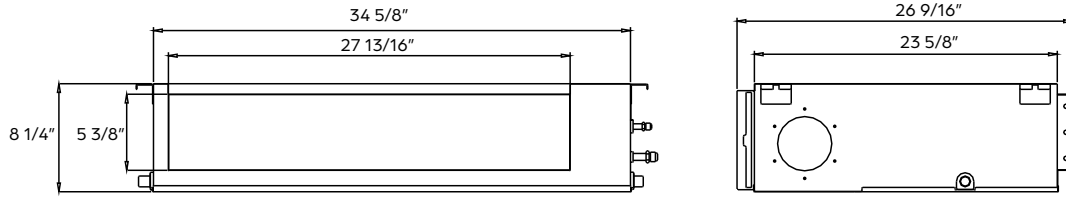

Air inlet dimensions

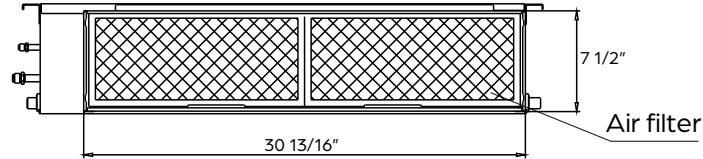

Mounting dimensions for ceiling bolts

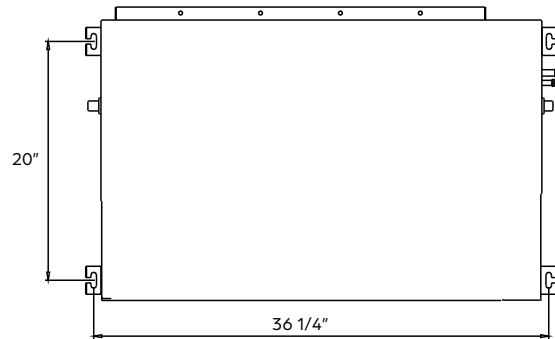

Installation clearances

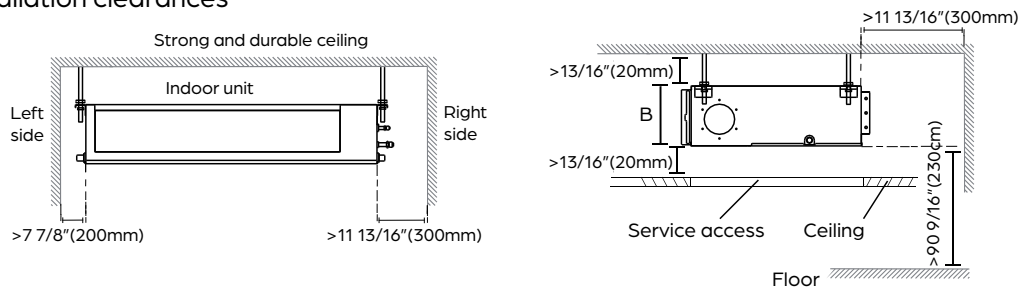

Maintenance access panel

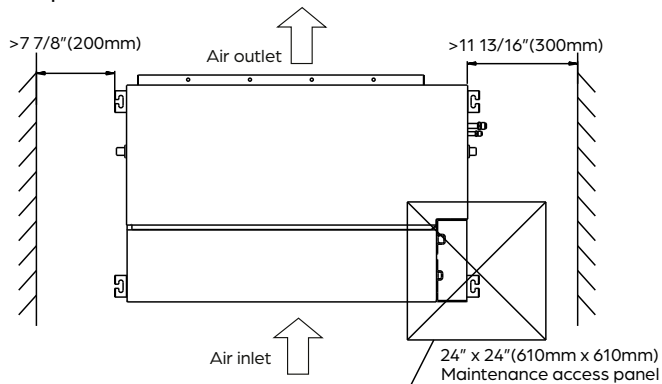



28,000 BTU/H MULTI-ZONE HEAT PUMP SYSTEM

SUBMITTAL COVER SHEET

PROJECT NAME _____

LOCATION _____

ARCHITECT _____

ENGINEER _____

CONTRACTOR _____

REFERENCE _____

SUBMITTED BY _____ DATE _____

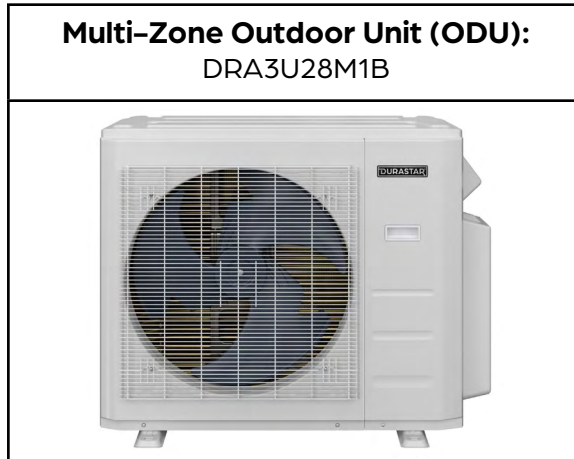

PRODUCT FEATURES

- Variable speed inverter compressor
- Quiet operation
- Low ambient heating down to -13 °F
- Low ambient cooling down to 5 °F
- Included base pan heater
- Auto restart
- Anti-corrosive coil coating
- Port adaptors included

SYSTEM DATA	
Refrigerant Type	R-410A
Refrigerant Charge (oz.)	91.7
Design Pressure (PSIG)	550/340
Outdoor Coil Coating	Golden Fin Coating

CAPACITIES		DUCTLESS	MIXED	DUCTED
Cooling (BTU/hr)	Rated ¹	27000	27000	28000
	at 5 °F ³	21010	21615	22220
	Minimum	8500	8888	9277
	Maximum	32000	31388	30776
Heating (BTU/hr)	Rated ²	28000	28000	28000
	at 5 °F ⁴	17680	16590	15500
	Minimum	8200	8264	8388
	Maximum	35000	31934	28869
Nominal IDU Capacity ⁵ (Min/Max)		15000/36000		

EFFICIENCY DATA	DUCTLESS	MIXED	DUCTED
SEER2	23.50	22.25	21.00
EER2	12.20	11.95	11.70
HSPF2	9.20	9.20	9.20
SEER	22.50	21.75	21.00
EER	12.00	11.60	11.20
HSPF	10.20	10.20	10.20
COP at 47 °F	3.70	3.68	3.66
COP at 5 °F	1.93	1.78	1.62





28,000 BTU/H MULTI-ZONE HEAT PUMP SYSTEM

SPECIFICATIONS - DRA3U28M1B

LINE SET REQUIREMENTS	
Connection Type	Flare
Liquid	3 x Ø1/4" (Ø6.35mm)
Gas	3 x Ø3/8" (Ø9.52mm)
Refrigeration Adaptors Included	3 x 3/8"--1/2"
Minimum Indoor Units Connected	2
Pre-Charge Length	22.5'
Maximum Length (combined IDUs)	197'
Maximum Length (per IDU)	98'
Minimum Length (per IDU)	10'
Max. Height Differential between IDU and ODU	49'
Additional Refrigerant for Ø1/4" Liquid Pipe (oz./ft)	0.161

ELECTRICAL DATA	DUCTLESS	DUCTED
Voltage/Phase/Frequency	208-230V, 1 Phase, 60 Hz	
Voltage Range	187-253V	
Recommended Breaker (Amps)	30	
Minimum Circuit Ampacity (Amps)	24.5	
Communication Wire Size	14*4 AWG Stranded	
Rated Current - Cooling (Amps) ¹	11.0	11.5
Rated Current - Heating (Amps) ²	11.0	10.5

¹ Measured at 95 °F.

² Measured at 47 °F.

³ Sensible Capacity: Indoor 80 °F DB, 67 °F WB // Outdoor 5 °F DB, 4 °F WB

⁴ Maximum Capacity: Indoor 70 °F DB, 67 °F WB // Outdoor 5 °F DB, 4 °F WB

⁵ If the total indoor unit load exceeds the nominal capacity of the outdoor unit, the practical output capacity of each indoor unit will be correspondingly reduced. This situation is very evident during heating mode.

OUTDOOR UNIT DATA		
Unit Dimensions	Width	37 1/4"
	Depth	16 1/8"
	Height	31 7/8"
Carton Dimensions	Width	42 15/16"
	Depth	19 11/16"
	Height	34 13/16"
Net Weight	139.8 lbs.	
Gross Weight	150.6 lbs.	
Cooling Operating Temperature	5 °F - 122 °F	
Heating Operating Temperature	-13 °F - 75 °F	
Airflow (CFM)	2129.4	
Sound Pressure (dB(A))	61	
Fan Speed (r/min)	Low	850
	Medium	900
	High	1050
Fan Motor Current Type	DC	

COMPRESSOR	
Type	DC Inverter Twin Cylinder Rotary
Oil Type	VG74
Oil Charge (oz.)	21 (620 ml)



28,000 BTU/H MULTI-ZONE HEAT PUMP SYSTEM

ODU DIMENSIONS - DRA3U28M1B

Clearances

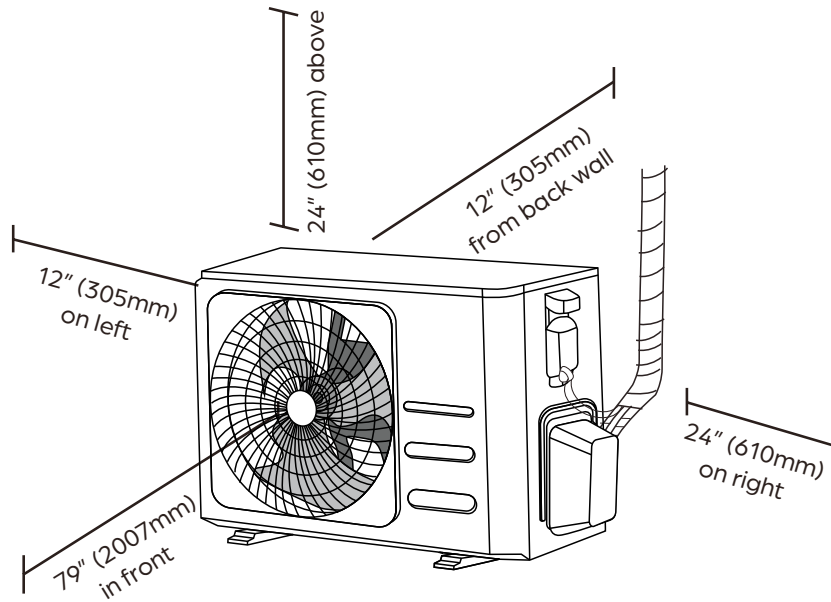

Dimensions

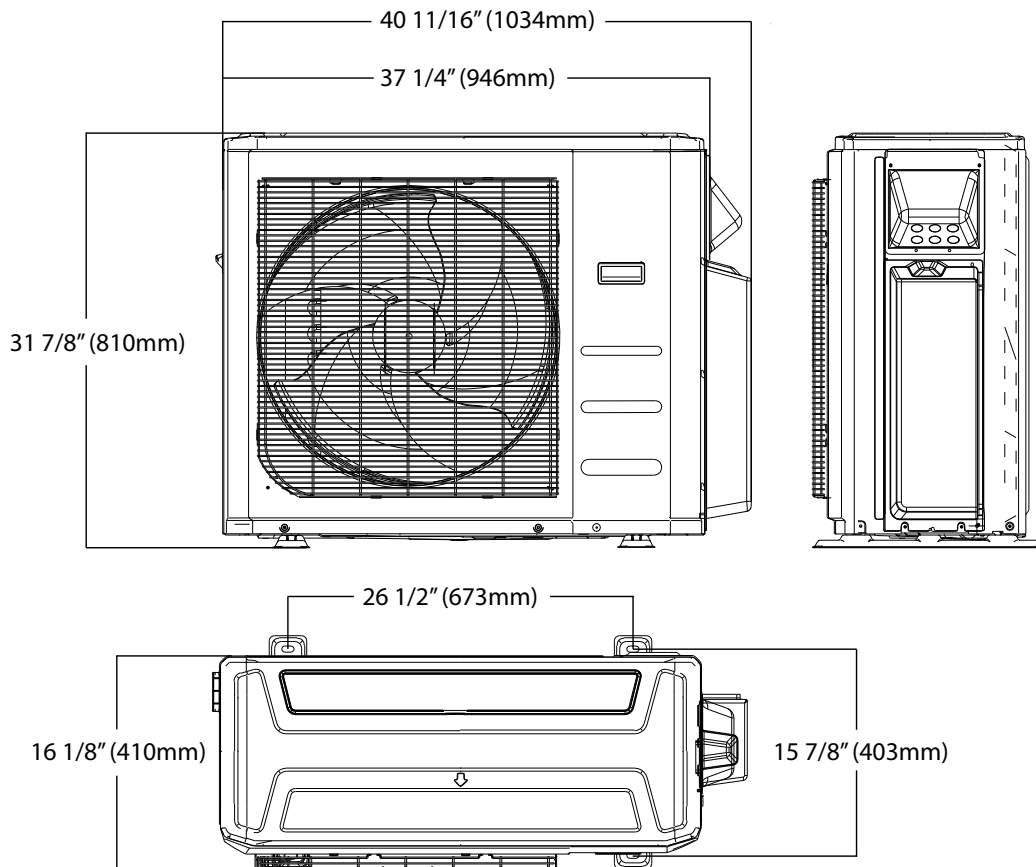

NOTE

Illustrations in this document are for explanatory purposes. The actual shape of your mini-split equipment may vary slightly.

Specifications are subject to change without notice.

© 2022 Ferguson Enterprises LLC

www.durastar.com