



# 28,000 BTU/H MULTI-ZONE HEAT PUMP SYSTEM

SUBMITTAL COVER SHEET

PROJECT NAME \_\_\_\_\_

LOCATION \_\_\_\_\_

ARCHITECT \_\_\_\_\_

ENGINEER \_\_\_\_\_

CONTRACTOR \_\_\_\_\_

REFERENCE \_\_\_\_\_

SUBMITTED BY \_\_\_\_\_ DATE \_\_\_\_\_

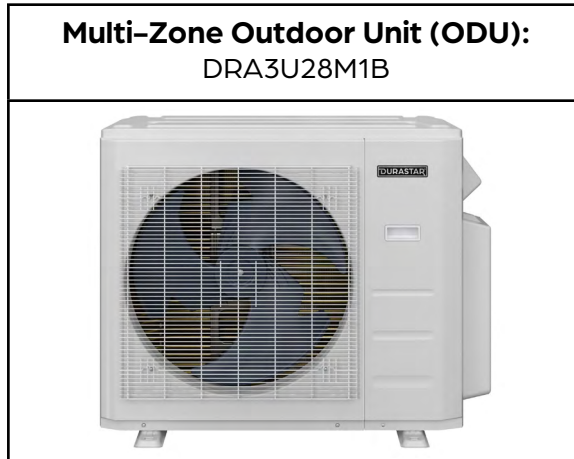

### PRODUCT FEATURES

- Variable speed inverter compressor
- Quiet operation
- Low ambient heating down to -13 °F
- Low ambient cooling down to 5 °F
- Included base pan heater
- Auto restart
- Anti-corrosive coil coating
- Port adaptors included

SYSTEM DATA	
Refrigerant Type	R-410A
Refrigerant Charge (oz.)	91.7
Design Pressure (PSIG)	550/340
Outdoor Coil Coating	Golden Fin Coating

CAPACITIES		DUCTLESS	MIXED	DUCTED
Cooling (BTU/hr)	Rated <sup>1</sup>	27000	27000	28000
	at 5 °F <sup>3</sup>	21010	21615	22220
	Minimum	8500	8888	9277
	Maximum	32000	31388	30776
Heating (BTU/hr)	Rated <sup>2</sup>	28000	28000	28000
	at 5 °F <sup>4</sup>	17680	16590	15500
	Minimum	8200	8264	8388
	Maximum	35000	31934	28869
Nominal IDU Capacity <sup>5</sup> (Min/Max)		15000/36000		

EFFICIENCY DATA	DUCTLESS	MIXED	DUCTED
SEER2	23.50	22.25	21.00
EER2	12.20	11.95	11.70
HSPF2	9.20	9.20	9.20
SEER	22.50	21.75	21.00
EER	12.00	11.60	11.20
HSPF	10.20	10.20	10.20
COP at 47 °F	3.70	3.68	3.66
COP at 5 °F	1.93	1.78	1.62





# 28,000 BTU/H MULTI-ZONE HEAT PUMP SYSTEM

SPECIFICATIONS - DRA3U28M1B

LINE SET REQUIREMENTS	
Connection Type	Flare
Liquid	3 x Ø1/4" (Ø6.35mm)
Gas	3 x Ø3/8" (Ø9.52mm)
Refrigeration Adaptors Included	3 x 3/8"--1/2"
Minimum Indoor Units Connected	2
Pre-Charge Length	22.5'
Maximum Length (combined IDUs)	197'
Maximum Length (per IDU)	98'
Minimum Length (per IDU)	10'
Max. Height Differential between IDU and ODU	49'
Additional Refrigerant for Ø1/4" Liquid Pipe (oz./ft)	0.161

ELECTRICAL DATA	DUCTLESS	DUCTED
Voltage/Phase/Frequency	208-230V, 1 Phase, 60 Hz	
Voltage Range	187-253V	
Recommended Breaker (Amps)	30	
Minimum Circuit Ampacity (Amps)	24.5	
Communication Wire Size	14*4 AWG Stranded	
Rated Current - Cooling (Amps) <sup>1</sup>	11.0	11.5
Rated Current - Heating (Amps) <sup>2</sup>	11.0	10.5

<sup>1</sup> Measured at 95 °F.

<sup>2</sup> Measured at 47 °F.

<sup>3</sup> Sensible Capacity: Indoor 80 °F DB, 67 °F WB // Outdoor 5 °F DB, 4 °F WB

<sup>4</sup> Maximum Capacity: Indoor 70 °F DB, 67 °F WB // Outdoor 5 °F DB, 4 °F WB

<sup>5</sup> If the total indoor unit load exceeds the nominal capacity of the outdoor unit, the practical output capacity of each indoor unit will be correspondingly reduced. This situation is very evident during heating mode.

OUTDOOR UNIT DATA		
Unit Dimensions	Width	37 1/4"
	Depth	16 1/8"
	Height	31 7/8"
Carton Dimensions	Width	42 15/16"
	Depth	19 11/16"
	Height	34 13/16"
Net Weight	139.8 lbs.	
Gross Weight	150.6 lbs.	
Cooling Operating Temperature	5 °F - 122 °F	
Heating Operating Temperature	-13 °F - 75 °F	
Airflow (CFM)	2129.4	
Sound Pressure (dB(A))	61	
Fan Speed (r/min)	Low	850
	Medium	900
	High	1050
Fan Motor Current Type	DC	

COMPRESSOR	
Type	DC Inverter Twin Cylinder Rotary
Oil Type	VG74
Oil Charge (oz.)	21 (620 ml)



# 28,000 BTU/H MULTI-ZONE HEAT PUMP SYSTEM

ODU DIMENSIONS - DRA3U28M1B

## Clearances

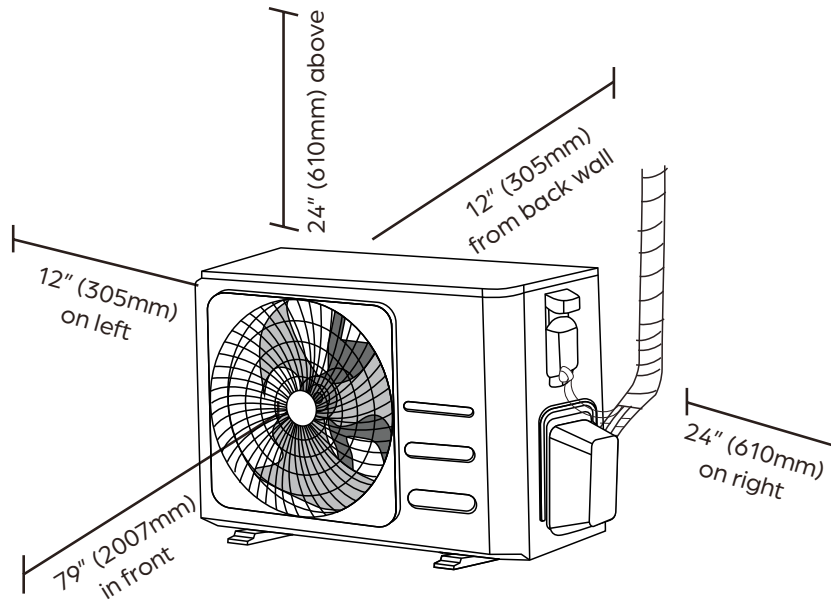

## Dimensions

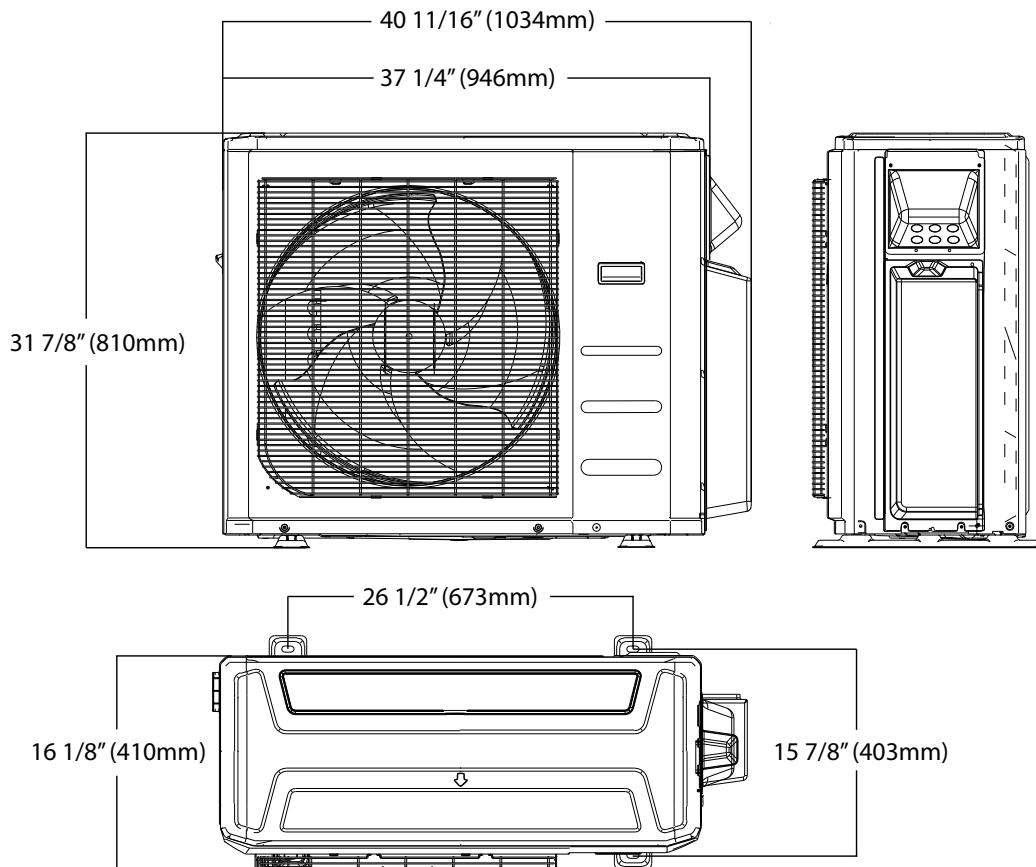

### NOTE

Illustrations in this document are for explanatory purposes. The actual shape of your mini-split equipment may vary slightly.



# 12,000 BTU/H CEILING CASSETTE

SUBMITTAL COVER SHEET

PROJECT NAME \_\_\_\_\_

LOCATION \_\_\_\_\_

ARCHITECT \_\_\_\_\_

ENGINEER \_\_\_\_\_

CONTRACTOR \_\_\_\_\_

REFERENCE \_\_\_\_\_

SUBMITTED BY \_\_\_\_\_ DATE \_\_\_\_\_

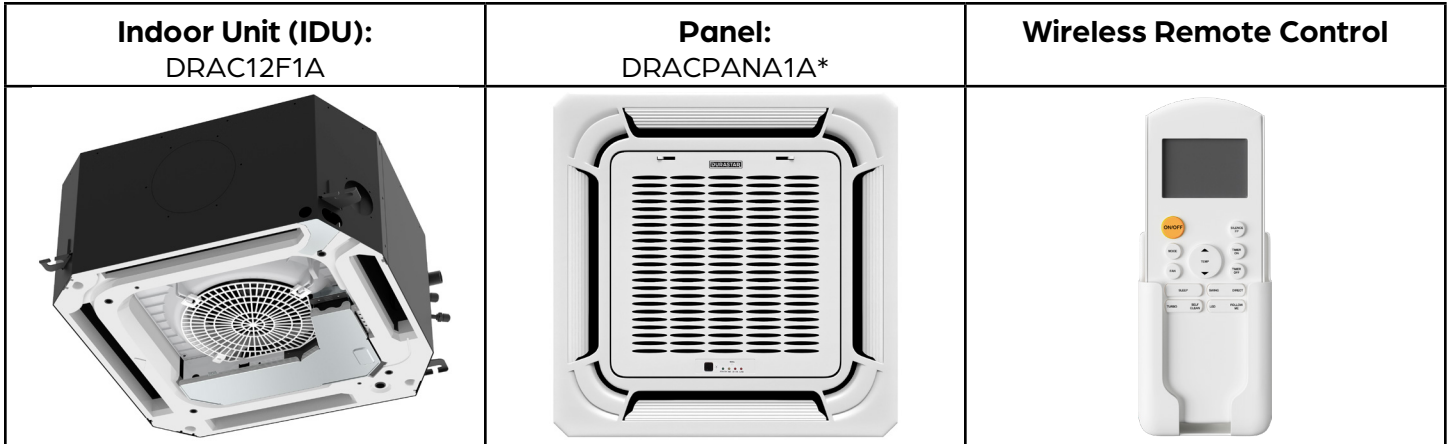

CAPACITIES		
Cooling Capacity (BTU/hr)	Rated	12000
Heating Capacity (BTU/hr)	Rated	12000

ELECTRICAL DATA	
Voltage/Phase/Frequency	208-230V, 1 Phase, 60 Hz

LINE SET REQUIREMENTS	
Connection Type	Flare
Liquid	Ø1/4" (Ø6.35mm)
Gas	Ø1/2" (Ø12.7mm)
Drain Port O.D. / Drain Hose I.D.	Ø1" (Ø25mm)

INDOOR UNIT FAN DATA		
Air Flow (CFM)	Low	261
	Medium	309
	High	379
Type	DC	
RLA	0.465	
Sound Pressure (dB(A))	Low	36
	Medium	39
	High	43

INDOOR UNIT DIMENSIONS		
Unit Dimensions	Width	22 7/16"
	Depth	22 7/16"
	Height	10 1/4"
Carton Dimensions	Width	26 1/16"
	Depth	26 1/16"
	Height	12 1/2"
Net Weight	35.3 lbs.	
Gross Weight	45.5 lbs.	

### PRODUCT FEATURES

- Wireless Remote Control with "Follow Me" Technology
- Auto Restart
- Auto Changeover
- 24-hour Timer
- Self Clean Function

\*Panel sold separately





# 12,000 BTU/H CEILING CASSETTE

DIMENSIONS - DRAC12F1A

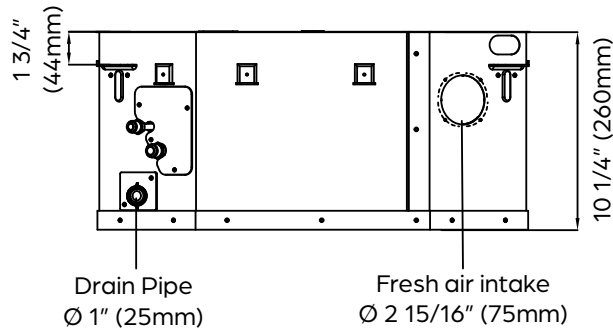
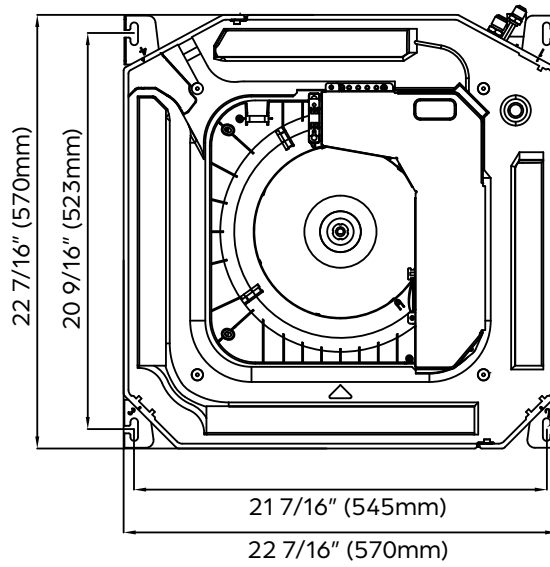

## DRACPANA1A:

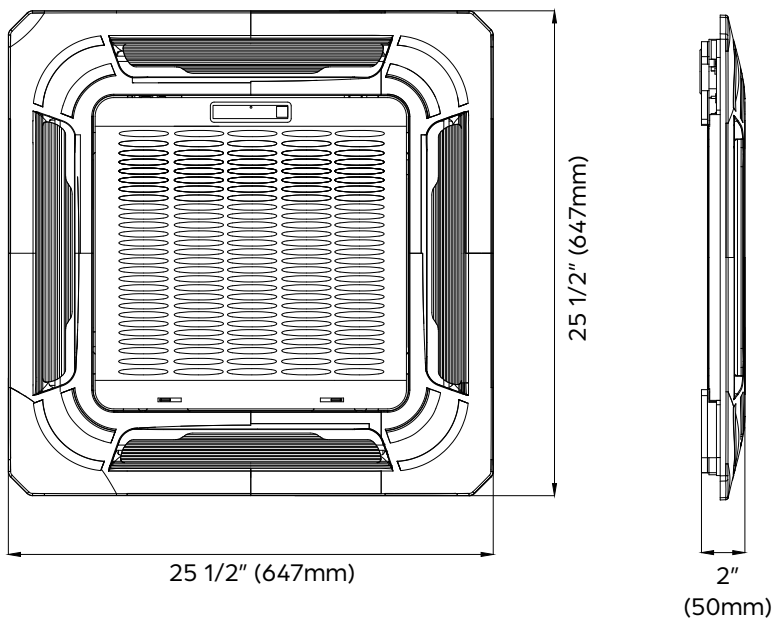



# 18,000 BTU/H CEILING CASSETTE

SUBMITTAL COVER SHEET

PROJECT NAME \_\_\_\_\_

LOCATION \_\_\_\_\_

ARCHITECT \_\_\_\_\_

ENGINEER \_\_\_\_\_

CONTRACTOR \_\_\_\_\_

REFERENCE \_\_\_\_\_

SUBMITTED BY \_\_\_\_\_ DATE \_\_\_\_\_

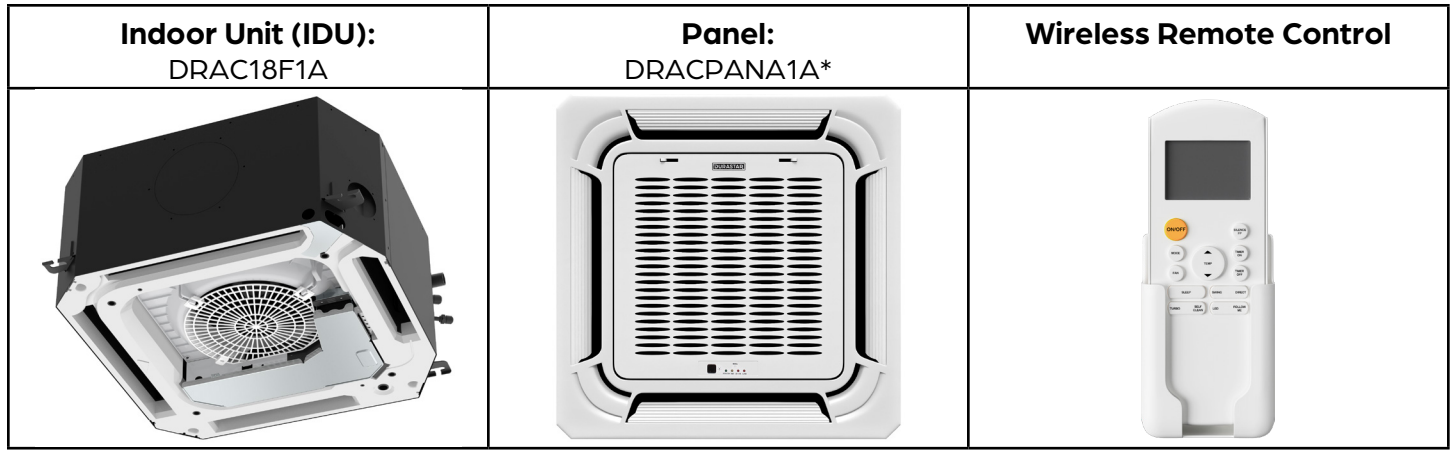

CAPACITIES		
Cooling Capacity (BTU/hr)	Rated	18000
Heating Capacity (BTU/hr)	Rated	18000

ELECTRICAL DATA	
Voltage/Phase/Frequency	208-230V, 1 Phase, 60 Hz

LINE SET REQUIREMENTS	
Connection Type	Flare
Liquid	Ø1/4" (Ø6.35mm)
Gas	Ø1/2" (Ø12.7mm)
Drain Port O.D. / Drain Hose I.D.	Ø1" (Ø25mm)

INDOOR UNIT FAN DATA		
Air Flow (CFM)	Low	415
	Medium	483
	High	560
Type	DC	
RLA	0.465	
Sound Pressure (dB(A))	Low	36
	Medium	39
	High	44

INDOOR UNIT DIMENSIONS		
Unit Dimensions	Width	22 7/16"
	Depth	22 7/16"
	Height	10 1/4"
Carton Dimensions	Width	26 1/16"
	Depth	26 1/16"
	Height	12 1/2"
Net Weight	35.7 lbs.	
Gross Weight	47.0 lbs.	

- PRODUCT FEATURES**
- Wireless Remote Control with "Follow Me" Technology
  - Auto Restart
  - Auto Changeover
  - 24-hour Timer
  - Self Clean Function

\*Panel sold separately

Specifications are subject to change without notice.  
 © 2021 Ferguson Enterprises LLC  
 www.durastar.com





# 18,000 BTU/H CEILING CASSETTE

DIMENSIONS - DRAC18F1A

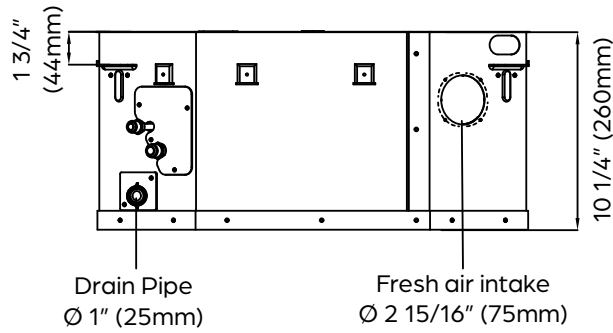
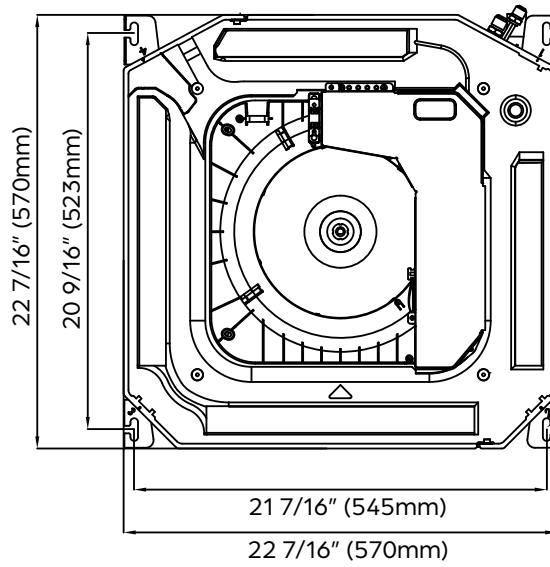

## DRACPANA1A:

