

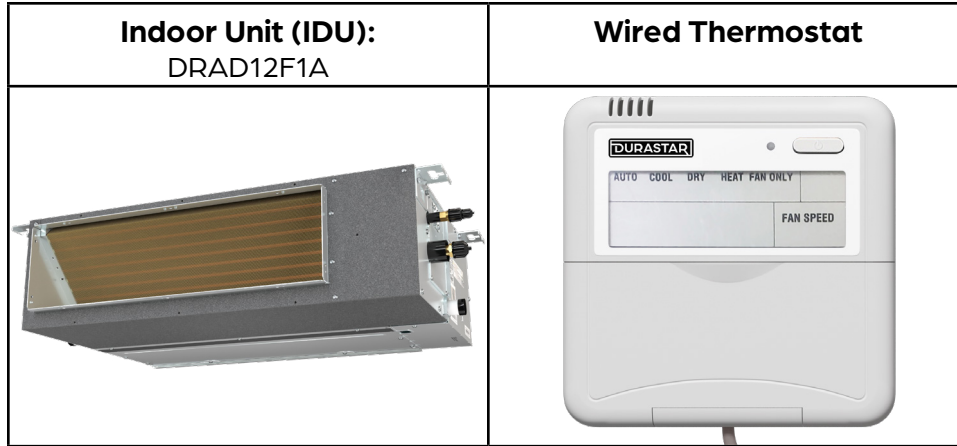

# 12,000 BTU/H SLIM DUCTED IDU

SUBMITTAL COVER SHEET

PROJECT NAME \_\_\_\_\_  
 LOCATION \_\_\_\_\_  
 ARCHITECT \_\_\_\_\_  
 ENGINEER \_\_\_\_\_  
 CONTRACTOR \_\_\_\_\_  
 REFERENCE \_\_\_\_\_  
 SUBMITTED BY \_\_\_\_\_ DATE \_\_\_\_\_



CAPACITIES		
Cooling Capacity (BTU/hr)	Rated	12000
Heating Capacity (BTU/hr)	Rated	12000

ELECTRICAL DATA	
Voltage/Phase/Frequency	208-230V, 1 Phase, 60 Hz

LINE SET REQUIREMENTS	
Connection Type	Flare
Liquid	Ø1/4" (Ø6.35mm)
Gas	Ø1/2" (Ø12.7mm)
Drain Port O.D. / Drain Hose I.D.	Ø1" (Ø25mm)

INDOOR UNIT DIMENSIONS		
Unit Dimensions	Width	27 9/16"
	Depth	19 15/16"
	Height	7 7/8"
Carton Dimensions	Width	33 7/8"
	Depth	21 1/4"
	Height	11 1/4"
Net Weight	39.2 lbs.	
Gross Weight	51.0 lbs.	

INDOOR UNIT FAN DATA		
Air Flow (CFM)	Low	177
	Medium	283
	High	353
Type	DC	
RLA	1.11	
Sound Pressure (dB(A))	Low	33.5
	Medium	36
	High	38
Static Pressure (in wg)	0-0.16	

### PRODUCT FEATURES

- Wired Thermostat Included
- Auto Restart
- Auto Changeover
- 24-hour Timer





# 12,000 BTU/H SLIM DUCTED IDU

DIMENSIONS - DRAD12F1A

## Unit and air outlet dimensions

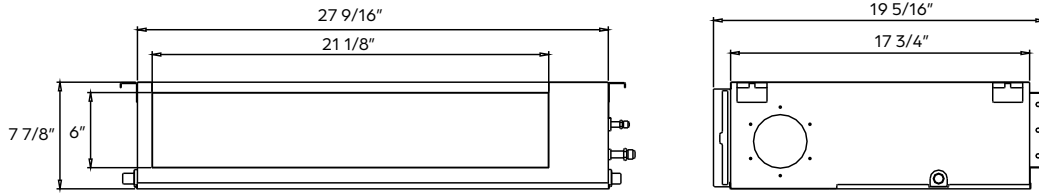

## Air inlet dimensions

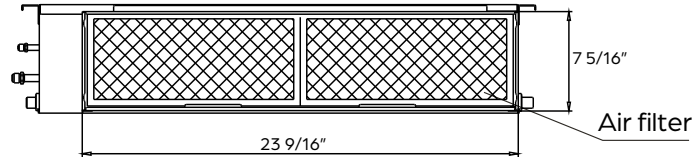

## Mounting dimensions for ceiling bolts

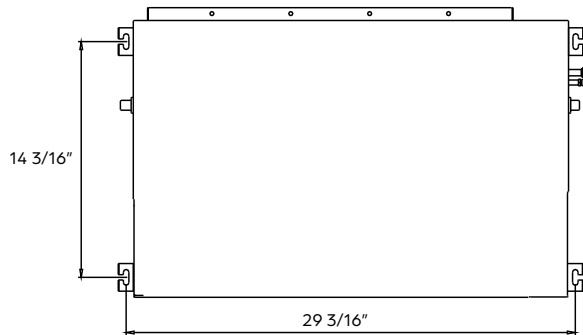

## Installation clearances

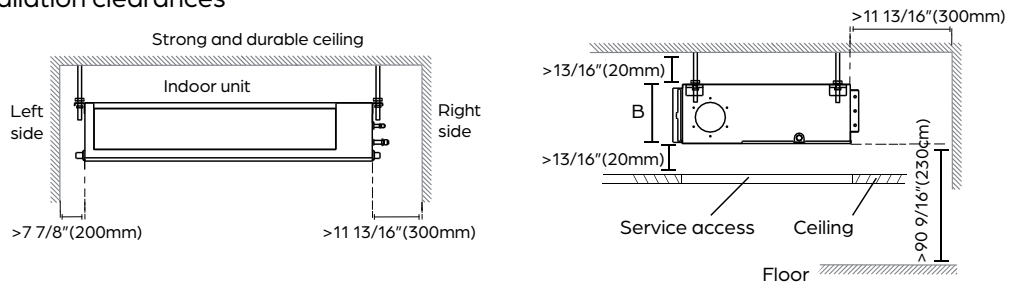

## Maintenance access panel

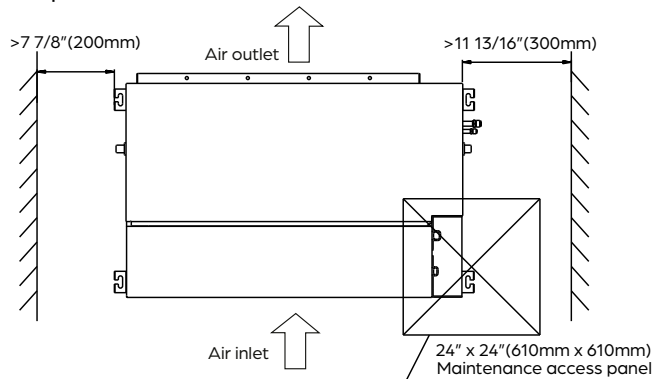



# 12,000 BTU/H WALL MOUNTED HEAT PUMP SYSTEM

SUBMITTAL COVER SHEET

PROJECT NAME \_\_\_\_\_

LOCATION \_\_\_\_\_



ARCHITECT \_\_\_\_\_

ENGINEER \_\_\_\_\_

CONTRACTOR \_\_\_\_\_

REFERENCE \_\_\_\_\_

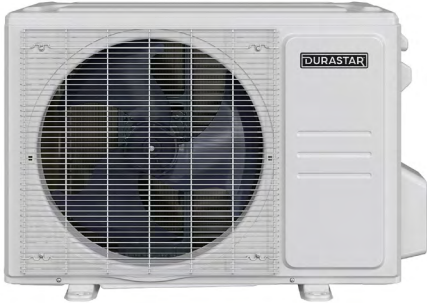
SUBMITTED BY \_\_\_\_\_ DATE \_\_\_\_\_

Indoor Unit (IDU): DRAW12F1B	Outdoor Unit (ODU): DRA1U12S1B	Wireless Remote Control
		

## PRODUCT FEATURES

- Wireless Remote Control with "Follow Me" Technology
- Variable Speed Inverter Compressor
- Auto Restart
- Sleep Mode
- Turbo Mode
- 24-Hour Timer Feature
- Quiet operation
- 46°F Freeze Protection
- Low ambient heating down to -13 °F
- Low ambient cooling down to 5 °F
- Included base pan heater
- Refrigerant leak detection
- Anti-corrosive fin coating

SYSTEM DATA	
Refrigerant Type	R-410A
Refrigerant Charge (oz.)	38.1
Design Pressure (PSIG)	550/340
Indoor/ Outdoor Coil Coating	Golden Fin Coating

EFFICIENCY DATA	
SEER2	23.1
EER2	13.0
HSPF2	10.8
SEER	22.2
EER	13.0
HSPF	11.0
COP at 47 °F	3.40
COP at 5 °F	1.80

CAPACITIES		
Cooling Capacity (BTU/hr)	Rated at 95 °F	12000
	Sensible at 5 °F <sup>3</sup>	8630
	Minimum	3600
	Maximum	13300
Heating Capacity (BTU/hr)	Rated at 47 °F	12000
	Maximum at 5 °F <sup>4</sup>	9500
	Minimum	4500
	Maximum	13500



Specifications are subject to change without notice.  
 © 2022 Ferguson Enterprises LLC  
 www.durastar.com



# 12,000 BTU/H WALL MOUNTED HEAT PUMP SYSTEM

SPECIFICATIONS

LINE SET REQUIREMENTS	
Connection Type	Flare
Liquid	Ø1/4" (Ø6.35mm)
Gas	Ø1/2" (Ø12.7mm)
Pre-Charge Length	25'
Minimum Length	10'
Maximum Length	82'
Maximum Height Differential	33'
Additional Refrigerant (oz./ft)	0.16

OUTDOOR UNIT		
Unit Dimensions	Width	30 1/8"
	Depth	11 15/16"
	Height	21 7/8"
Carton Dimensions	Width	34 15/16"
	Depth	13 1/4"
	Height	24"
Net Weight	63.7 lbs.	
Gross Weight	69.0 lbs.	
Cooling Operating Temperature	5 °F – 122 °F	
Heating Operating Temperature	-13 °F – 75 °F	
Voltage/Phase/Frequency	208-230V, 1 Phase, 60 Hz	
Voltage Range	187-253V	
Recommended Breaker (Amps)	15	
Minimum Circuit Ampacity (Amps)	13	
Communication Wire Size	14*4 AWG Stranded	
Rated Current – Cooling (Amps) <sup>1</sup>	4.05	
Rated Current – Heating (Amps) <sup>2</sup>	4.5	
Sound Pressure (dB(A))	53.5	

INDOOR UNIT		
Unit Dimensions	Width	31 9/16"
	Depth	7 7/8"
	Height	11 5/8"
Carton Dimensions	Width	34 7/16"
	Depth	11 1/4"
	Height	14 15/16"
Net Weight	18.7 lbs.	
Gross Weight	24.3 lbs.	
Indoor Unit Air Flow (CFM)	Low	153
	Medium	194
	High	291
Moisture Removal (Pints/day)	78.24	
Drain Port O.D.	Ø5/8" (Ø16mm)	
Recommended Breaker (Amps)	15	
Sound Pressure (dB(A))	Low	25
	Medium	36
	High	42

COMPRESSOR	
Type	DC Rotary Inverter
Oil Type	Ester Oil VG74
Oil Charge (oz.)	10.5 (310 ml)

<sup>1</sup> Measured at 95 °F.

<sup>2</sup> Measured at 47 °F.

<sup>3</sup> Sensible Capacity: Indoor 80 °F DB, 67 °F WB // Outdoor 5 °F DB, 4 °F WB

<sup>4</sup> Maximum Capacity: Indoor 70 °F DB, 67 °F WB // Outdoor 5 °F DB, 4 °F WB



# 12,000 BTU/H WALL MOUNTED HEAT PUMP SYSTEM

IDU DIMENSIONS - DRAW12F1B

## Unit Dimensions

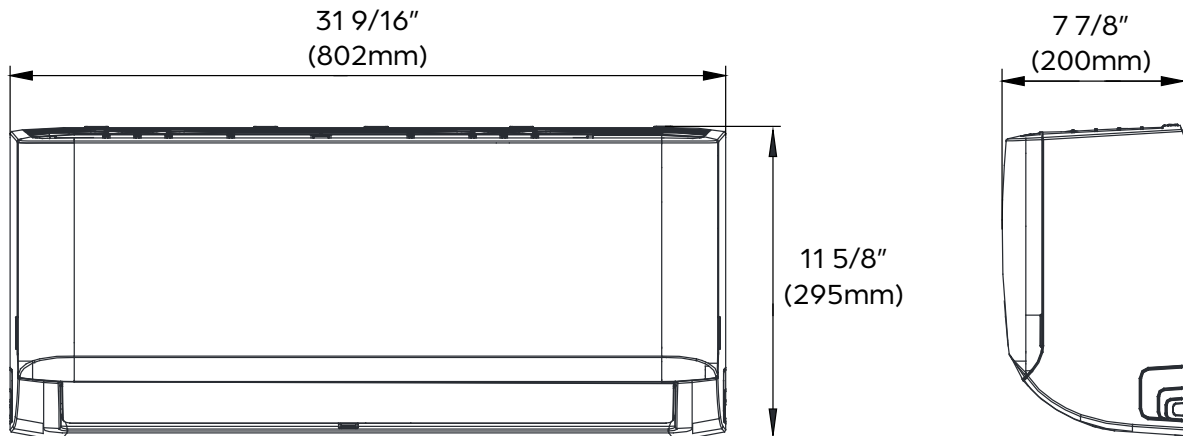

## Mounting Plate Dimensions

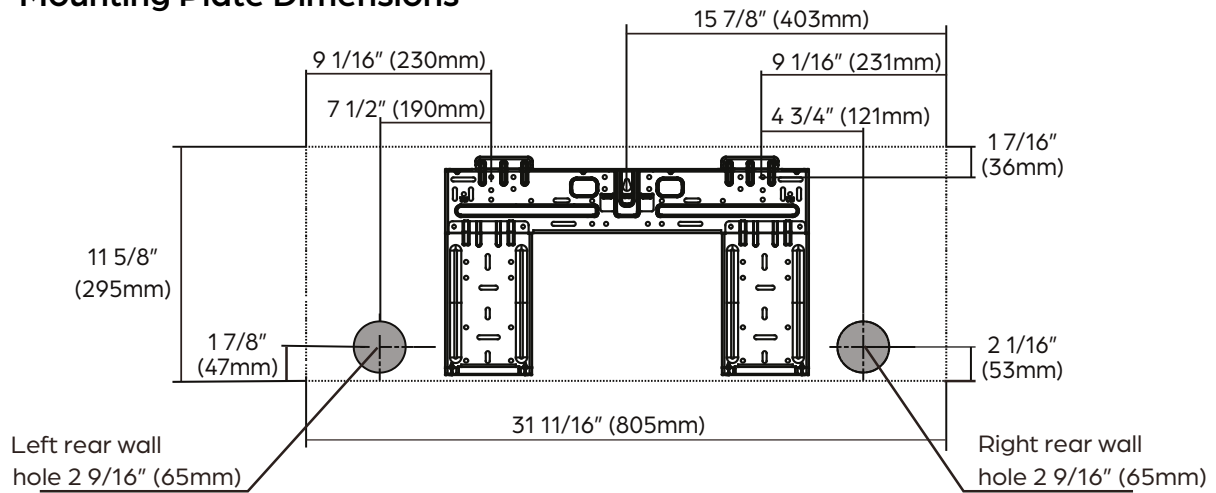

## Clearance Distances

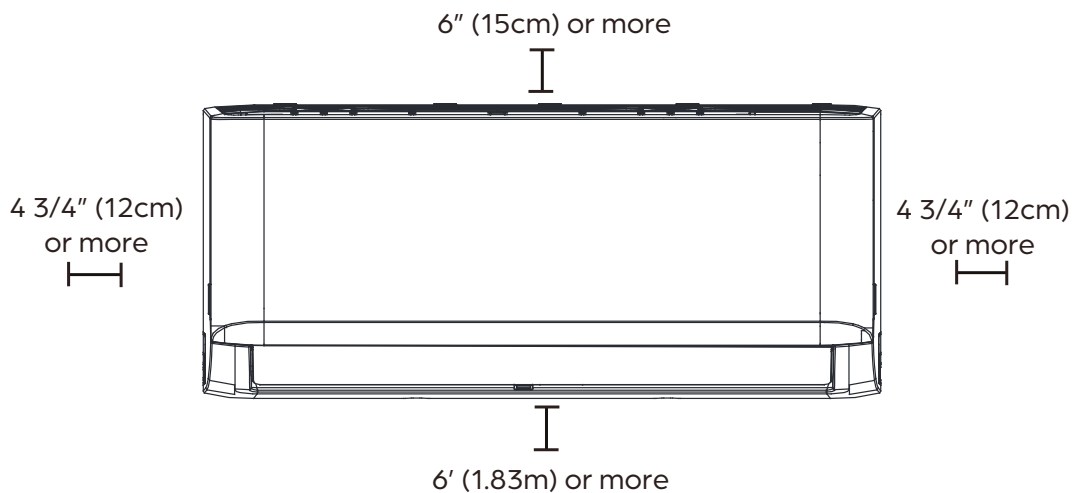



# 12,000 BTU/H WALL MOUNTED HEAT PUMP SYSTEM

ODU DIMENSIONS - DRA1U12S1B

## Clearances

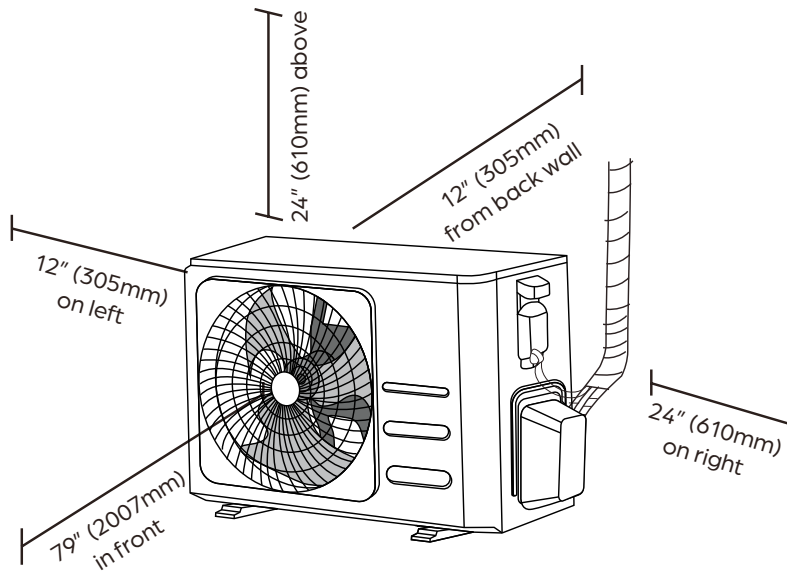

## Dimensions

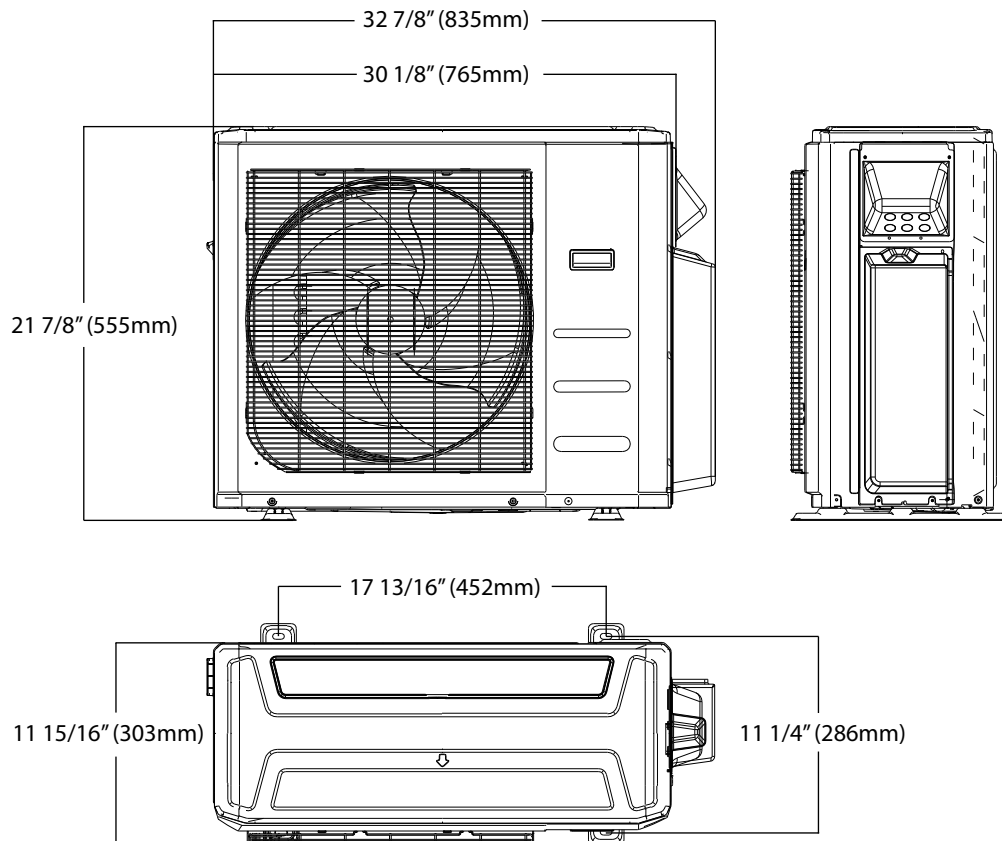

### NOTE

Illustrations in this document are for explanatory purposes. The actual shape of your mini-split equipment may vary slightly.