



ILLUSION

SHOWER DOOR INSTALLATION INSTRUCTIONS

IMPORTANT

DreamLine™ reserves the right to alter, modify or redesign products at any time without prior notice. For the latest up-to-date technical drawings, manuals or any other details please refer to the support.BathAuthority.com web page.

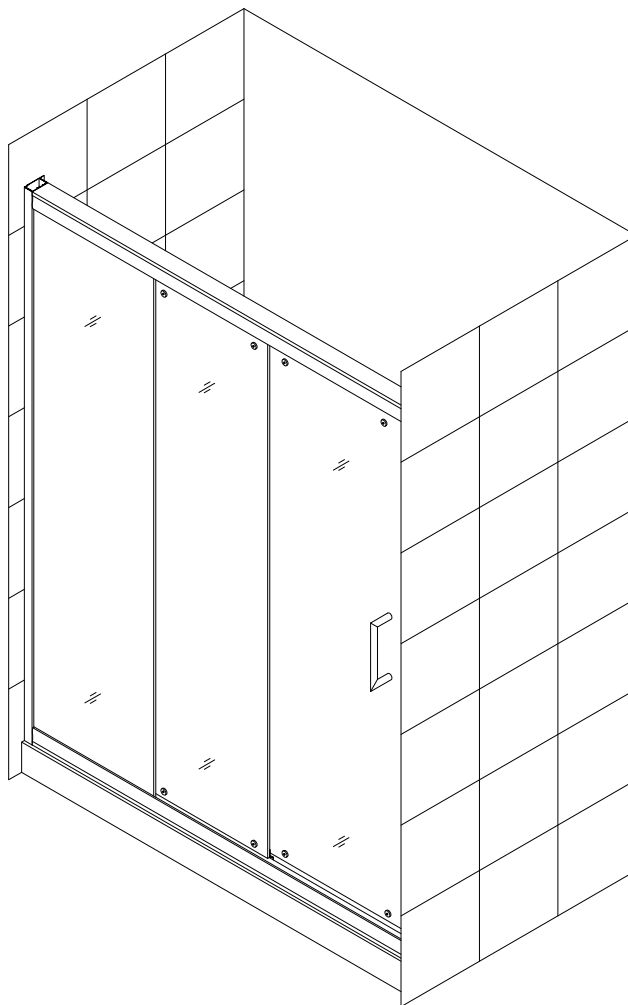

Please carefully read the instructions before installing. If you have any questions regarding installation, please call our technical support specialists Monday through Friday 9:00 AM – 5:00 PM EST at 1-866-731-8378, ext. 3 or e-mail our technical support group at support@BathAuthority.com.

For more information on [DreamLine™ Shower Doors](http://www.BathAuthority.com) please visit www.BathAuthority.com

Preparation

1. After opening all boxes and packages, read this introduction carefully. Check that all of the needed parts are included in the package, by marking all the components on the "Detailed Diagram of Shower Door Components". Examine boxes and packages for shipping damage. If the unit has been damaged, has a finishing defect, or has missing parts, please contact our customer support department within 3 business days of the delivery date. Please note that **DreamLine™ will not replace any damaged products or missing parts free of charge after 3 business days or if the product has been installed.** Feel free to contact DreamLine™ if you have any questions.
2. **Please note that you should consult your local building codes with questions on installation compliance standards. Building and plumbing codes may vary by location, and DreamLine is not responsible for code compliance standards for your project.**
3. Please insure that prior to the installation the installation surface is leveled and solid and will be able to support the total weight of the unit. Also make sure the walls are at right angles. While some adjustment in leveling of the door is possible, irregular installation surface level or improper angle of side walls will result in serious problems for your installation. Please, note that some adjustments and drilling might be necessary during the installation process.
4. **Please, NOTE! This door has only 1/2" out-of-plumb adjustment. Make sure your walls are as close to being plumb as possible.**

Tools Required

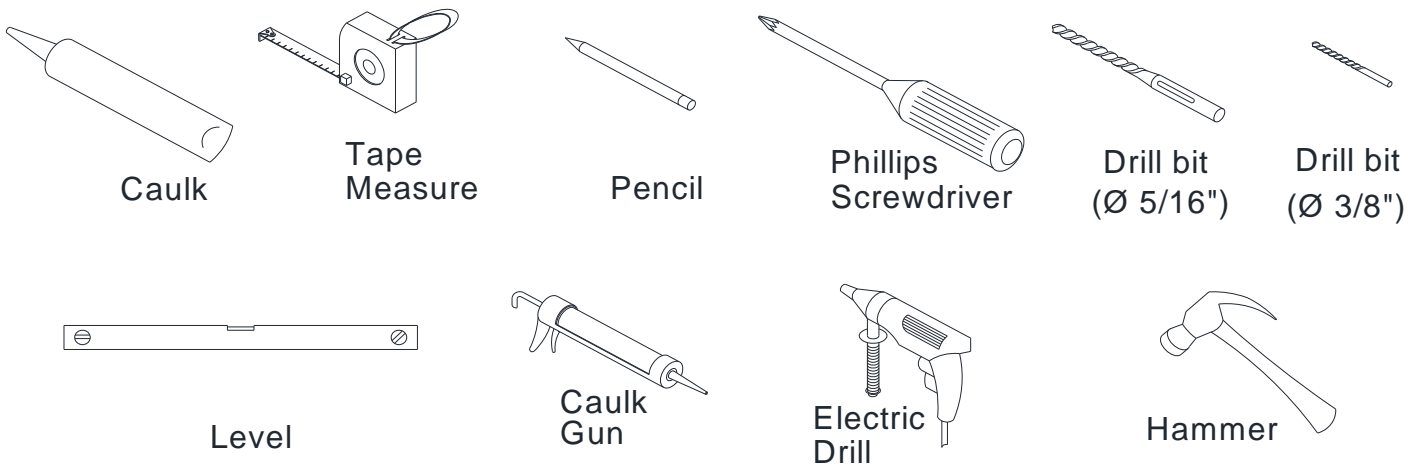

Detailed Diagram of Shower Door Components

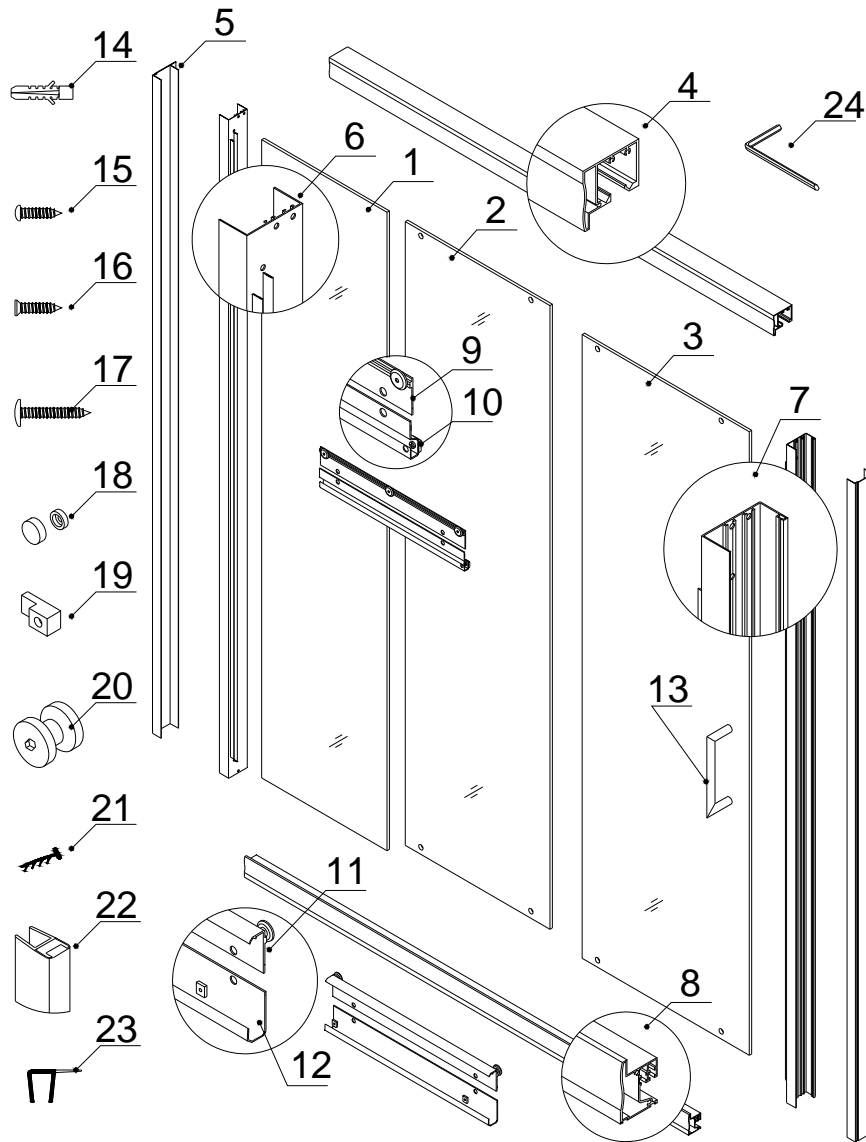

Packing List

01	Stationary glass	1pc	13	Handle	1pc
02	Glass door 1	1pc	14	Wall anchor	8pcs
03	Glass door 2	1pc	15	Round head screw ST4.2x10	4pcs
04	Upper guide rail	1pc	16	Countersunk screw ST4.2x16	2pcs
05	Wall profile	2pcs	17	Round head screw ST4.2x30	18pcs
06	Glass profile 1	1pcs	18	Decorative cover	4pcs
07	Glass profile 2	1pcs	19	Glass holder	2pcs
08	Bottom guide rail	1pc	20	Glass bolt	8 pairs
09	Roller assembly 1	1pc	21	Single Side strip	1pc
10	Bottom guide 1	1pc	22	Magnetic strip	1pc
11	Roller assembly 2	1pc	23	Side strip	2pcs
12	Bottom guide 2	1pc	24	Hex wrench	1pc

NOTE: Unpack your unit carefully and inspect it. Lay it out and identify all parts using the detailed diagram and packing list in your manual as a reference. Before discarding the carton, check for small hardware bags that tend to fall to the bottom of the box. If any parts are damaged or missing, please contact DreamLine™ for replacement.

Shower Door Assembling

1. Connect the **Upper guide rail (04)** to the **Glass profile 1 (06)** using the **Round head screw ST4.2×30 (17)**.

Slide the **Roller assembly 2 (11)** into the groove of the **Upper guide rail** and connect the **Glass profile 2 (07)** to the **Upper guide rail**.

Connect the **Bottom guide rail (08)** to the bottom end of the **Glass profile 1** and the **Glass profile 2** using the **Round head screw ST4.2×30 (17)**

See Fig. 1 and Fig. 2 for details.

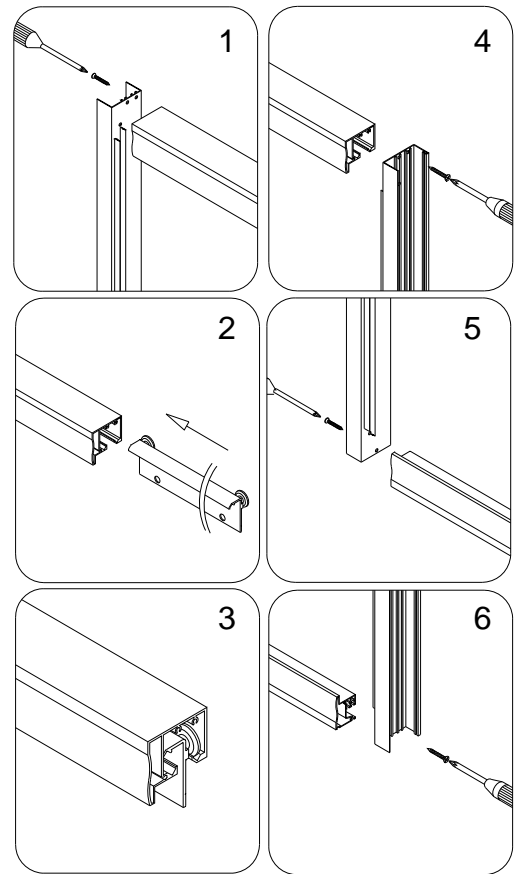

Fig. 1

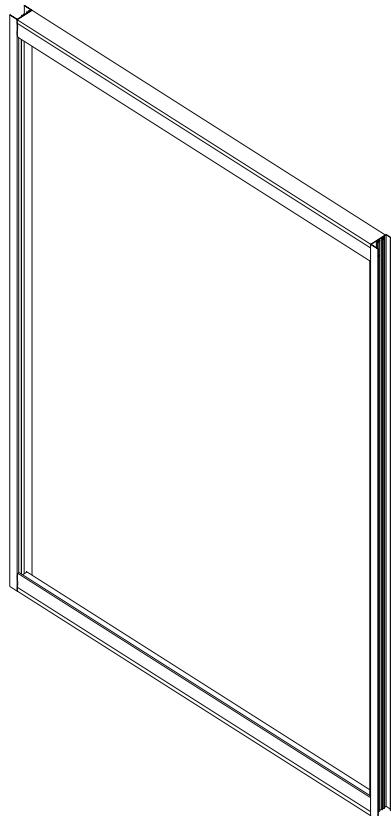

Fig. 2

2. Push the **Stationary glass (01)** into the groove of the left **Glass profile 1 (06)** along the guide rails.

Secure the **Stationary glass** with the **Glass clamps (19)** screwed into the upper and bottom guide rail using **Flat head screw ST4.2×16 (16)**. Attach the **Single side strip (21)** into the groove of the **Glass profile 1** along the **Stationary glass**.

See Fig 3 and Fig. 4 for details.

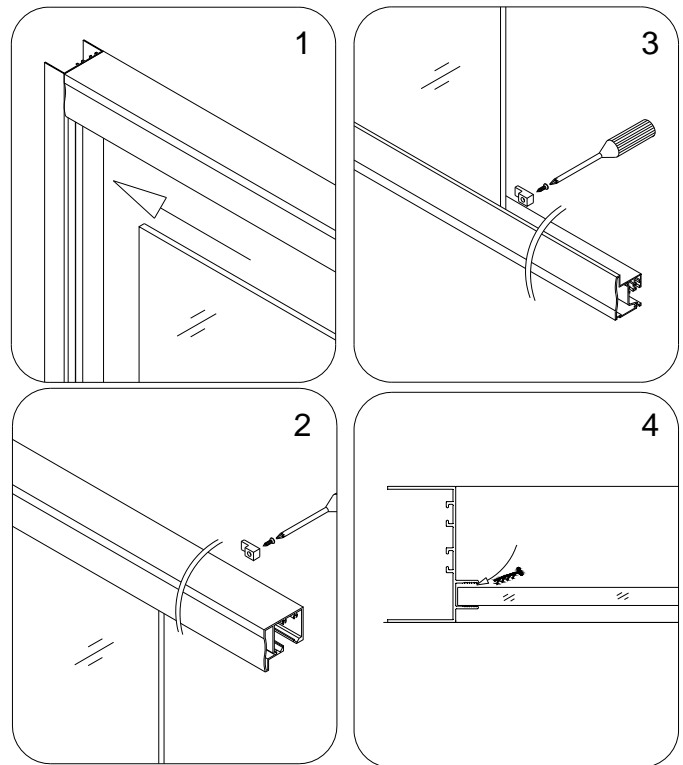

Fig. 3

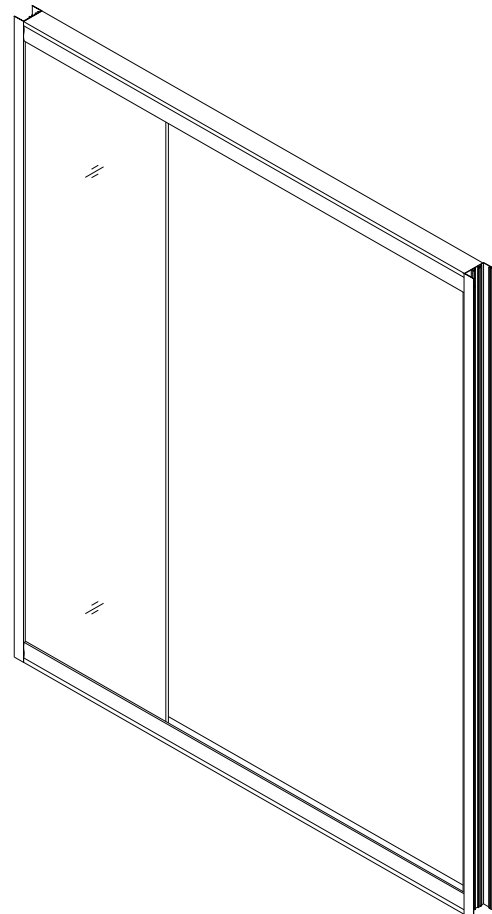

Fig. 4

3. Secure the **Roller assembly 1 (09)** to the top of the **Glass door 1 (02)** with the **Glass bolts (20)** using the **Hex wrench (24)**.

See Fig. 5 for details.

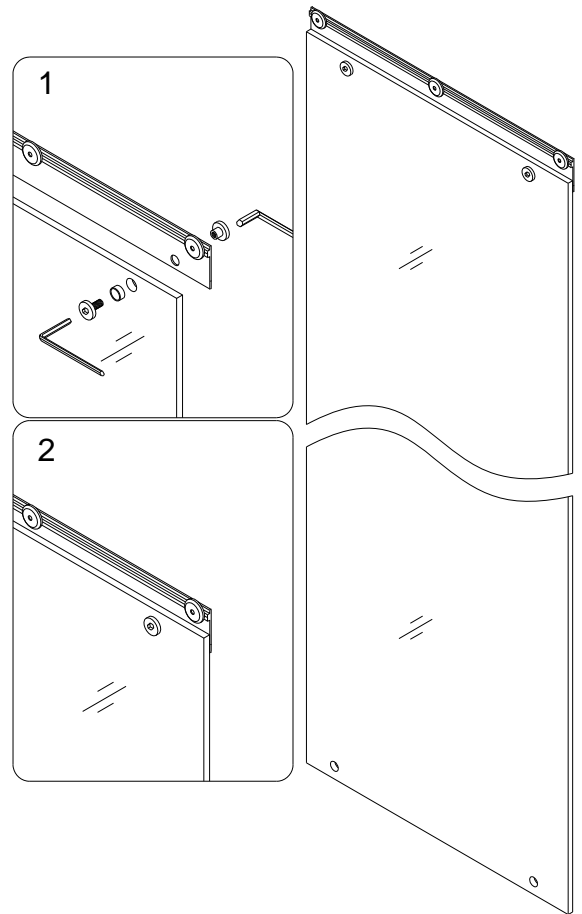

Fig. 5

4. Suspend the **Glass door 1 (02)** with the installed **Roller assembly 1 (09)** into the **Upper guide rail (04)**.

See Fig. 6 for details.

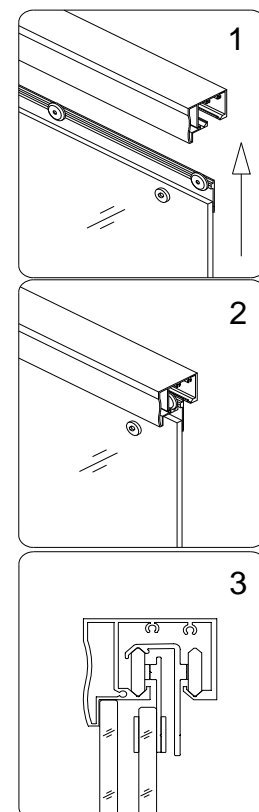

Fig. 6

5. Slide the **Bottom guide 1 (10)** into the **Bottom guide rail (08)**.

Fasten the **Bottom guide 1** to the **Glass door 1 (02)** using the **Glass bolts (20)**. Tighten using **Hex wrench (24)**.

NOTE: Pay attention to directions of the glass bolts.

See Fig. 7 and Fig. 8 for details.

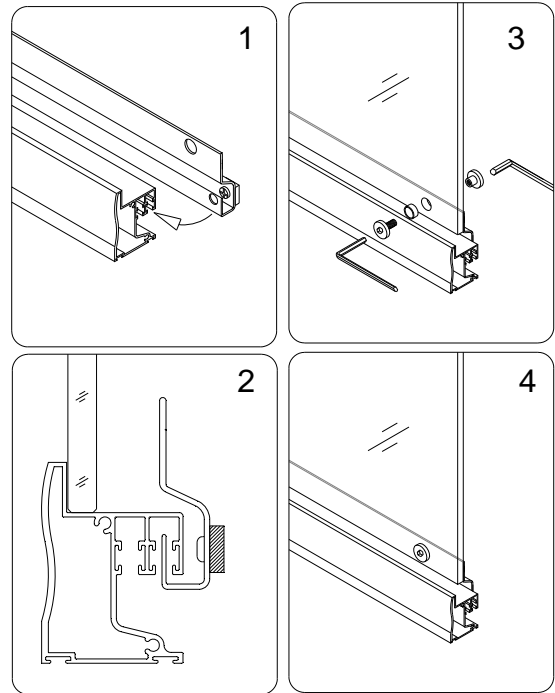

Fig. 7

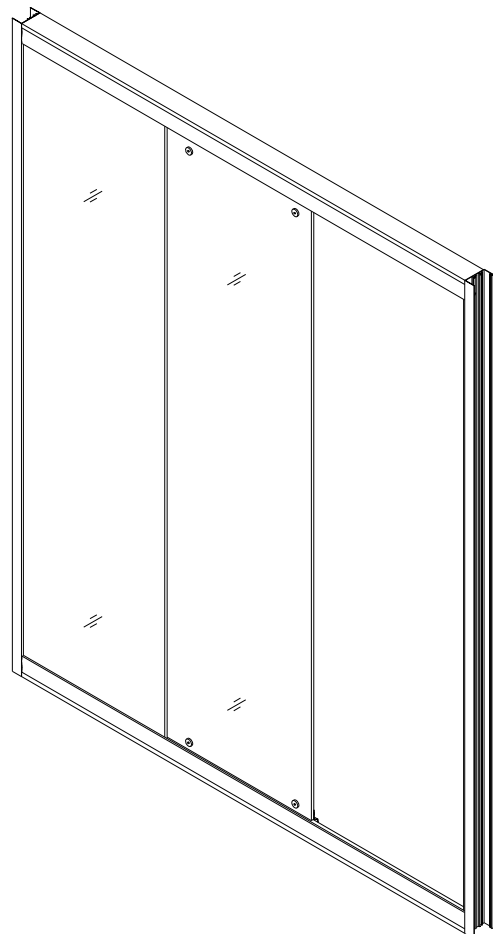

Fig. 8

6. Place the **Glass door 2 (03)** near the **Roller assembly 2 (11)** and fasten them with the **Glass bolts (20)** using the **Hex wrench (24)**.

Slide the **Bottom guide 2 (12)** into the **Bottom guide rail (08)**.

Secure the **Glass door 2 (03)** to the **Bottom guide 2 (12)** and fasten it with the **Glass bolts (20)** using the **Hex wrench**.

See Fig. 9 and Fig. 10 for details.

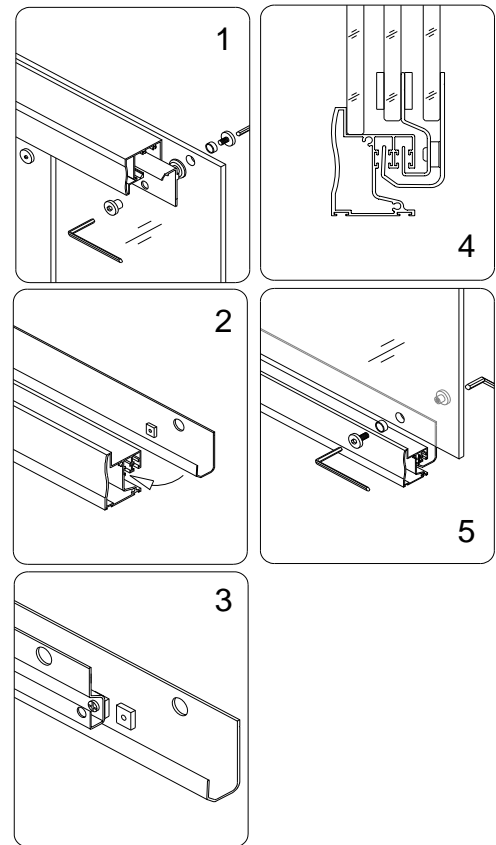

Fig. 9

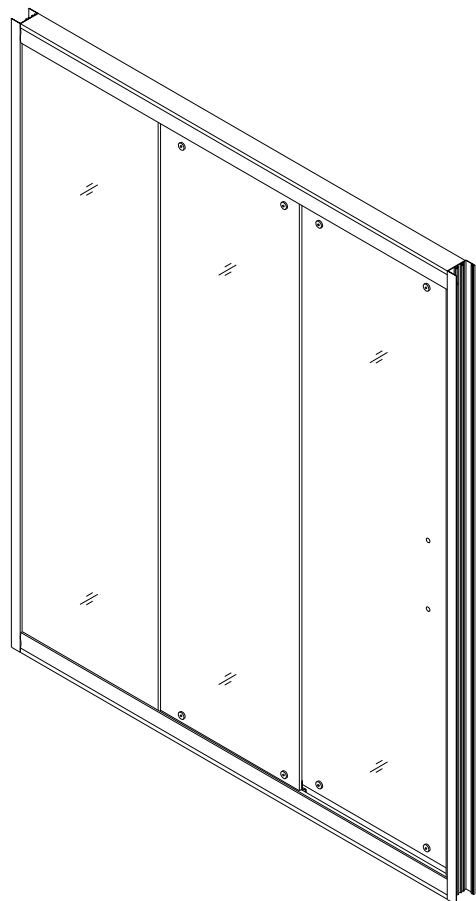

Fig. 10

Shower Door Installation

The shower door has to be installed against a finished floor and finished walls.

See Fig. 11 for details.

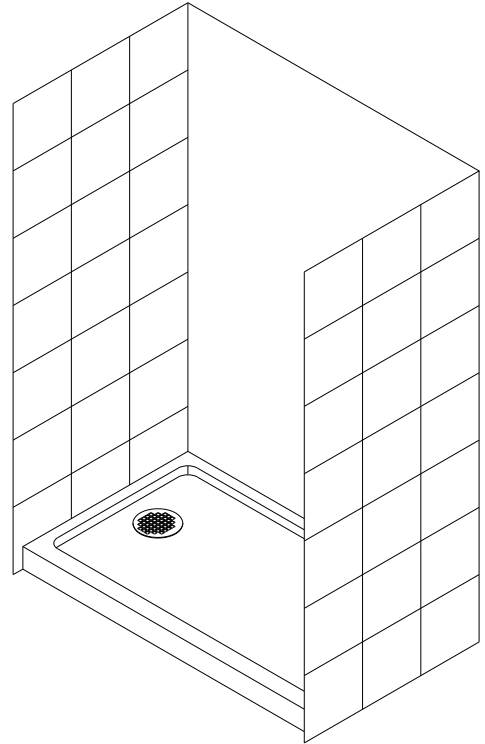

Fig. 11

7. Press the **Wall profiles (05)** on the **Glass profile 1 (06)** and **Glass profile 2 (07)**.

Make sure the flange of the wall profile faces inside the shower.

See Fig. 12 and Fig. 13 for details.

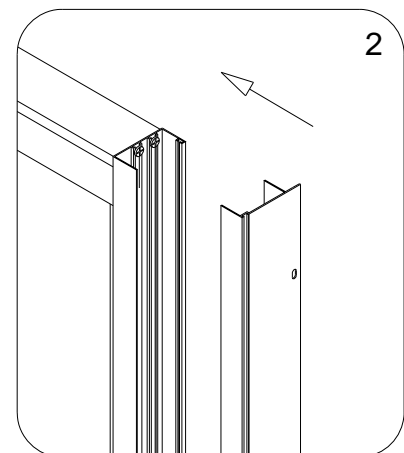
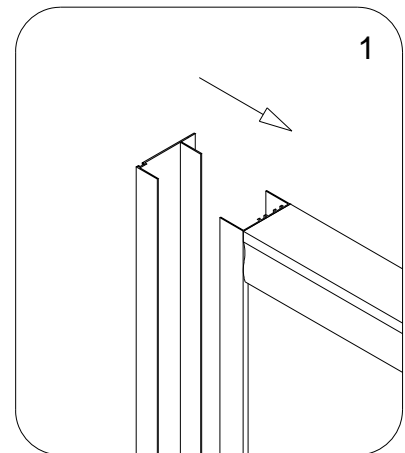

Fig. 12

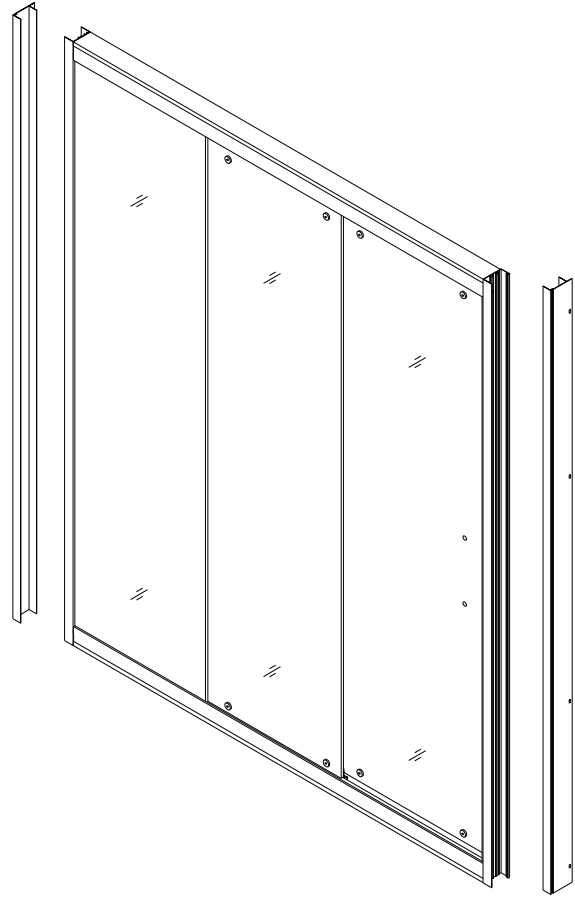

Fig. 13

8. Move the finished Shower door assembly into the shower base or threshold and push it against the walls. If your top and bottom wall opening measurements are different or if the walls are out-of-plumb, make adjustment by slightly pulling the **Wall profiles** out of the **Glass Profiles**. Use the Level to adjust the **Wall profiles** in the vertical position.

See Fig. 14 for details.

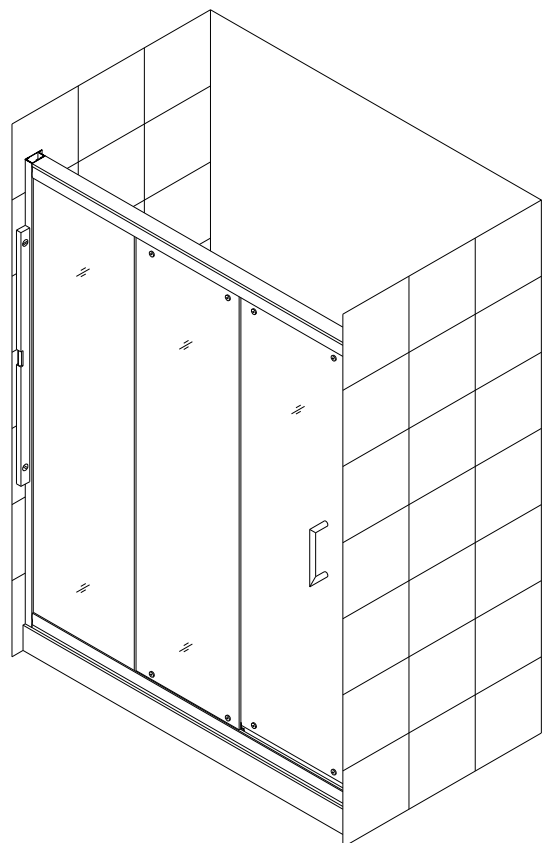

Fig. 14

9. Using help to hold this Shower door assembly in the right position, mark the drill holes on the wall through the holes on the flange of the **Wall Profile**.

Gently set the assembled unit aside. Drill the holes in the wall using $\text{Ø } 5/16''$ drill bit and insert the **Wall anchors (14)**.

Apply silicone along the wall profiles and around the holes on the wall. Also apply silicone under the bottom guide rail. Place the whole shower door assembly back into the designated position and secure it to the walls using the **Round head screws ST4.2×30 (17)**.

See Fig. 15 for details.

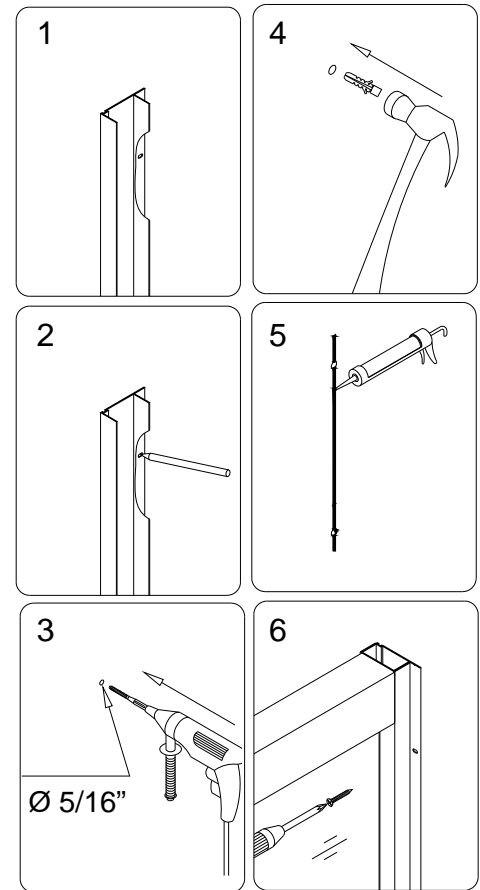

Fig. 15

10. Do the final adjustments of the assembled unit in the **Wall profiles**.

Drill the holes in the **Glass profiles (01)** and **(02)** through the predrilled holes using $\text{Ø } 1/8''$ drill bit on the top and the bottom of the **Wall profiles (05)**.

ATTENTION: Make sure not to drill the holes throughout, only the first layer of the wall profile.

Secure the **Wall profile** and the **Glass profile** with the **Round head screws ST4.2×10 (15)**.

Cover the exposed screw heads with the **Decorative covers (18)**.

See Fig. 16 for details.

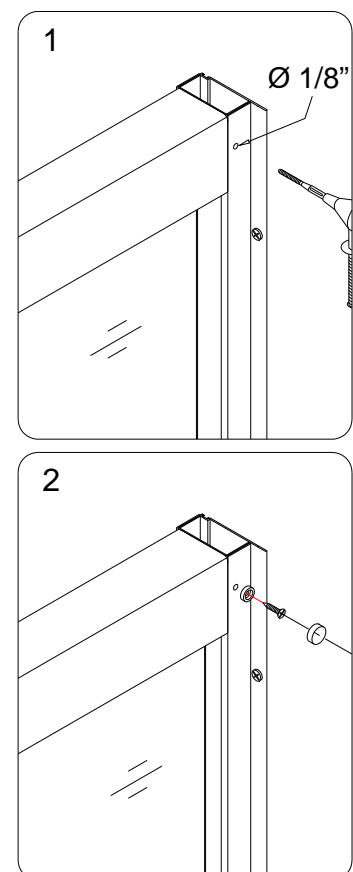

Fig. 16

11. Fasten the **Handle (13)** to the **Glass door 2 (03)**.

Press the **Magnetic strip (22)** on the vertical edge of the **Glass door 2** between the **Glass door 2** edge and the **Glass profile 2 (07)**.

Press the **Side strips (23)** on the glass door edges.

See Fig. 17 for details.

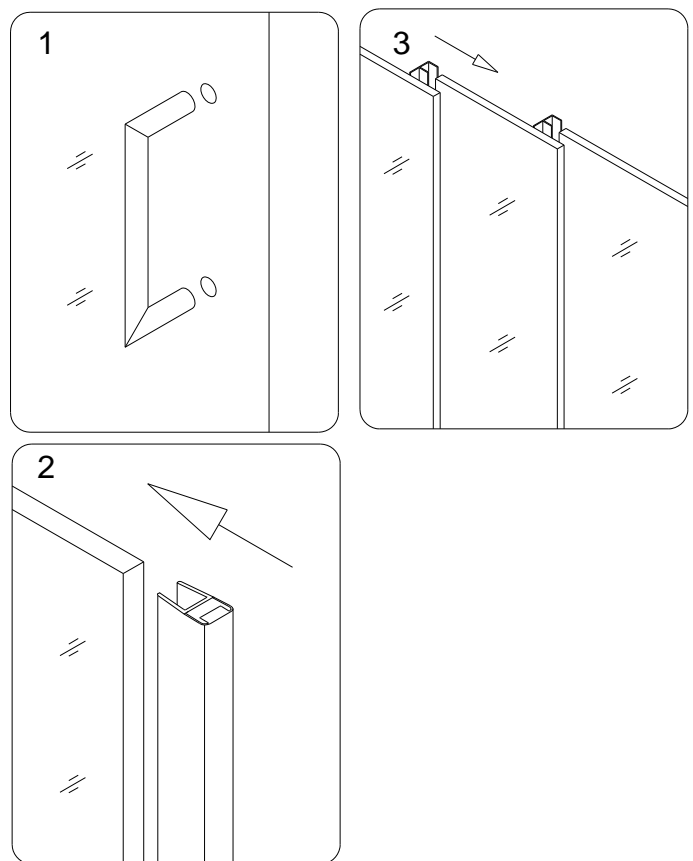

Fig. 17

12. Apply silicone along the connection of the **Wall profiles (05)** with the wall, as well as between the **Bottom guide rail (08)** and the Shower base or the threshold.

See fig. 18 for details.

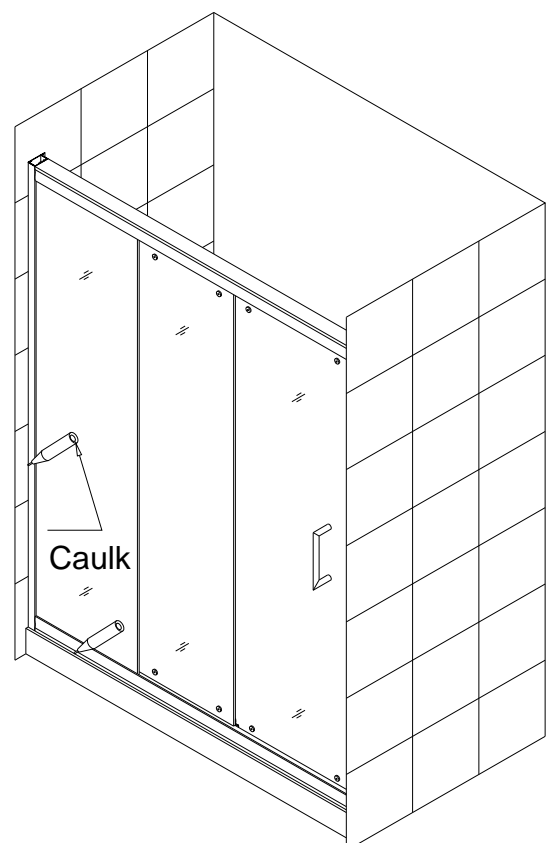

Fig. 18

Product Maintenance

To insure long lasting life for your acrylic back walls, wipe them off after each use with a soft cloth. To clean the acrylic back walls use non-abrasive sprays or cream based cleaners. Never use abrasive cleansers, metal brushes or scrapers that could scratch or dull the surface.

To insure long lasting life for your glass shower products, wipe them off after each use with a soft cloth. Rinse and wipe of the glass using either soft cloth or squeegee to prevent soap buildup. Never use abrasive cleaners and cleaning products that contain scoring agent because this may scratch the surface. Never use bristle brushes or abrasive sponges.

To assure a long lasting finish wipe off the metal parts after each use with a soft cloth. Do not use abrasive cleaners or cleaning products containing ammonia, bleach or acid. If accidentally used, rinse the surface as soon as possible to prevent finish peeling or corrosion. After cleaning the shiny finishes, rinse thoroughly and wipe dry with soft cloth. Clean stainless steel surfaces at least once a week. When applying stainless steel cleaner or polish, work with (not across) the grain. Never use abrasive sponge or cloth, steel wool or wired brushes.

This is Bath Authority LLC's ("DreamLine") exclusive written warranty effective April 1, 2011

This warranty extends only to the original owner/end-user for household use only and is not transferable to a subsequent owner. This warranty applies only to DreamLine™ products purchased from an authorized dealer and installed in United States or Canada. Proof of purchase (original sales receipt) must be provided with all warranty claims. **In no event shall the liability of DreamLine™ exceed the purchase price of the unit.**

If DreamLine™ shower doors, shower enclosures and shower bases are used commercially, DreamLine™ warrants such products to be free from defects in material and workmanship for one (1) year from initial date of purchase from an authorized dealer, with all other terms of this warranty applying except duration. If DreamLine™ vanities, vessel sinks and shower columns are used commercially, DreamLine™ warrants such products to be free from defects in material and workmanship for three (3) months from initial date of purchase from an authorized dealer, with all other terms of this warranty applying except duration. **DreamLine™ Jetted and Steam Shower Cabins are not intended for commercial use and there is no warranty extended for these products for commercial use.** DreamLine™ is not responsible for loss of use or profit under any circumstances.

DreamLine™ hereby disclaims all warranties for products sold as a dealer or store displays. DreamLine™ hereby disclaims all warranties for products used outside of the United States or Canada whether expressed or implied, including but not limited to the implied warranties of merchantability and fitness for a particular purpose.

DreamLine™ will, at its election, repair, replace with product of equal value or make appropriate adjustment where DreamLine's analysis or inspection of warranty claim discloses any such defects occurring in normal usage within the warranty period. DreamLine warranty obligation shall be discharged upon tender of replacement or repair. Purchaser's refusal to accept the tender terminates warranty obligation.

Cost of freight for returning products to DreamLine™ for repairs or replacement under this limited warranty are the responsibility of the customer. Cost of freight associated with shipping of replacement product or parts to the customer may be charged to customer. Any product replaced or repaired during the warranty period will be covered only for the remaining period of the original warranty. In no event will DreamLine be liable for costs of repair or replacement of any installation material, including but not limited to tiles, marble, etc. **DreamLine™ is not responsible for installation, removal or reinstallation costs of any product requiring warranty services.**

Improper modification or alterations of any DreamLine™ products will void the warranty. Any DreamLine products repairs must be performed by either a DreamLine authorized agent or a licensed experienced professional contractor. This warranty shall not apply to breakage or damages caused by normal wear and tear, fault, carelessness, abuse, misuse, misapplication, improper maintenance, alteration or modification of the unit, as well as chemical or natural corrosion, accident, fire, flood, act of God or any other casualty. Improper care and cleaning will void the warranty. Never use cleaners containing abrasive cleansers, ammonia, bleach, acids, waxes, alcohol, solvents or other products not recommended for chrome or similar finish, glass or acrylic. This will void the warranty. For additional product maintenance instructions please refer to product installation manuals. The warranty does not extend to any non-DreamLine™ plumbing or components installed by installers, end users or by any party other than DreamLine™.

THE FOREGOING WARRANTIES ARE IN LIEU OF ALL OTHER WARRANTIES, EXPRESSED OR IMPLIED, INCLUDING BUT NOT LIMITED TO THE IMPLIED WARRANTIES OF MERCHANTABILITY AND FITNESS FOR A PARTICULAR PURPOSE. BATH AUTHORITY LLC ("DREAMLINE") AND/OR SELLER DISCLAIM ALL LIABILITY FOR SPECIAL, INCIDENTAL OR CONSEQUENTIAL DAMAGES. DREAMLINE™ IS NOT LIABLE FOR PERSONAL INJURIES OR DEATH TO ANY PERSON OR FOR ANY DIRECT, SPECIAL, INCIDENTAL OR CONSEQUENTIAL DAMAGE, LOSS OF USE, LOSS OF TIME, LOSS OF PROFITS, INCONVENIENCE, INCIDENTAL EXPENSES, LABOR OR MATERIAL CHARGES, OR ANY OTHER COSTS RESULTING FROM THE USE OF ITS PRODUCTS OR PERTAINING TO THE APPLICATION OF THE PRESENT WARRANTY, OR RESULTING FROM THE REMOVAL OR REPLACEMENT OF ANY PRODUCT OR ELEMENT OR PART COVERED BY THIS WARRANTY.

DreamLine™ is not responsible for product code compliance or for verifying code restrictions on installation or use and any such compliance is excluded from this warranty. DreamLine™ reserves the right to modify this warranty at any time - such warranty modification will not alter warranty applicable at the time of sale of the products in question. The warranty terms for specific products are:

SHOWER DOORS, SHOWER ENCLOSURES AND SHOWER BASES

DreamLine™ warrants shower doors, shower enclosures and shower bases to be free from defects in workmanship and materials under normal residential use for a period of five (5) years from the initial date of purchase by the owner/end-user, contractor or builder from an authorized dealer.

SHOWER CABINS (JETTED & STEAM)

DreamLine™ warrants glass, acrylic and finish to be free from defects in workmanship for a period of five (5) years from initial date of purchase by the owner/end-user, contractor or builder from an authorized dealer; and plumbing, electrical and steam generator components for a period of one (1) year from the initial date of purchase by the owner/end-user, contractor or builder from an authorized dealer.

SHOWER COLUMNS

DreamLine™ warrants shower columns to be free from defects in workmanship and materials under normal residential use for a period of one (1) year from the initial date of purchase by the owner/end-user, contractor or builder from an authorized dealer.

VANITIES AND VESSEL SINKS

DreamLine™ warrants bathroom vanities and vessel sinks to be free from defects in workmanship and materials under normal residential use for a period of one (1) year from the initial date of purchase by the owner/end-user, contractor or builder from an authorized dealer.

Some states/provinces do not allow limitations on how long an implied warranty lasts, or the exclusion or limitation of special, incidental or consequential damages, so these limitations and exclusions may not apply to you. This warranty gives you specific legal rights. You may also have other rights, which vary from state/province to state/province.



TEL: 866-731-8378 – 215-957-1411

FAX: 866-227-9245 – 215-893-1780

WWW.BATHAUTHORITY.COM

For more information on [DreamLine™ Shower Doors](http://www.BathAuthority.com) please visit www.BathAuthority.com