

Montclair One Door Medicine Cabinet



Specifications

- Solid wood frame
- Particle board side panels
- Pre-Assembled design
- Chestnut Glaze finish
- 1 door, 2 shelves



Dimensions

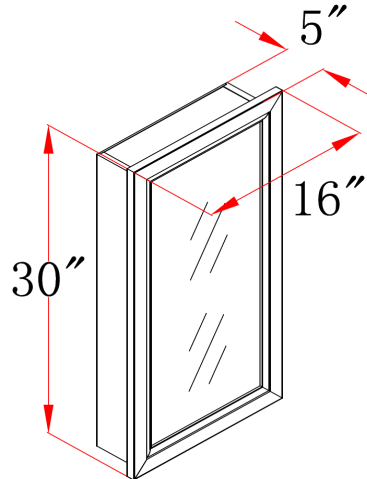

Warranty & Compliances

Warranty Limited 1 year warranty
California 93120 Compliant



Order Codes & Finishes/Colors

Fully Assembled

16"w x 5"d x 30"h

541375

Type:
Job:
Order Code:
Approvals:

Design House reserves the right to make changes in materials, specifications & models at any time. Design House also reserves the right to discontinue product without notice or obligation.