

Montclair Bank of Drawers



Specifications

- Solid wood door frames and drawer fronts
- Full extension ball bearing drawer glides
- Oil rubbed bronze hardware with TruMatch™ finish
- Durable water-resistant finish
- Chestnut Glaze Finish



Dimensions

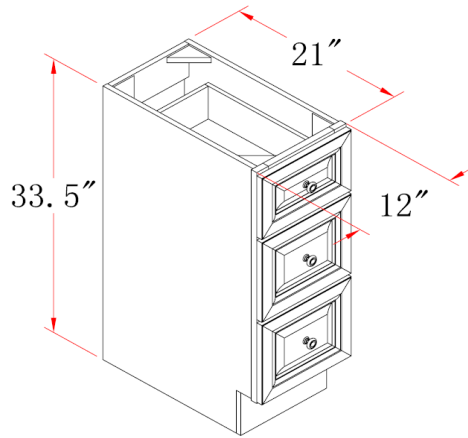

Warranty & Compliances

Warranty Limited 1 year warranty
California 93120 Compliant



Order Codes & Finishes/Colors

Fully Assembled

12"w x 21"d x 33.5"h

539551

Type:

Job:

Order Code:

Approvals:

Design House reserves the right to make changes in materials, specifications & models at any time. Design House also reserves the right to discontinue product without notice or obligation.