

Millbridge Recessed Toilet Paper Holder

Matte Black

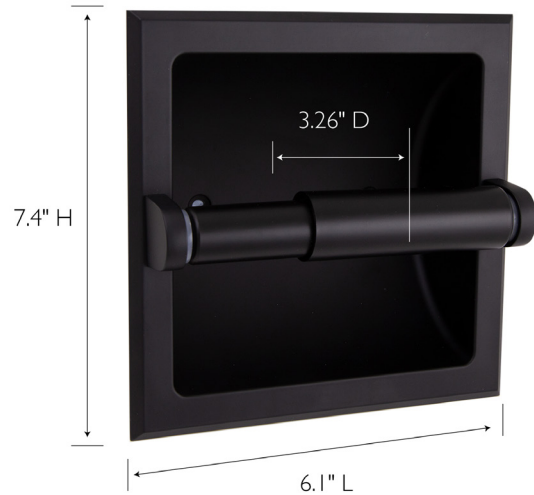

SPECIFICATIONS

MATERIAL CONSTRUCTION:	Zinc
ASSEMBLY REQUIRED:	No
TOOLS NEEDED FOR INSTALLATION:	Screwdriver
ASSEMBLED DIMENSIONS:	7.4" H x 6.1" L x 3.26" D
ASSEMBLED WEIGHT:	1.03 lbs.
MIN. LENGTH:	7.4"
MAX LENGTH:	7.4"
SCREWS INCLUDED:	Yes
DRYWALL ANCHORS INCLUDED:	Yes

WARRANTY:	1-Year limited warranty
LEGAL FOR SALE IN CALIFORNIA:	Yes
ADA COMPLIANT:	N/A



TYPE:
JOB:
ORDER CODE:
APPROVALS: