

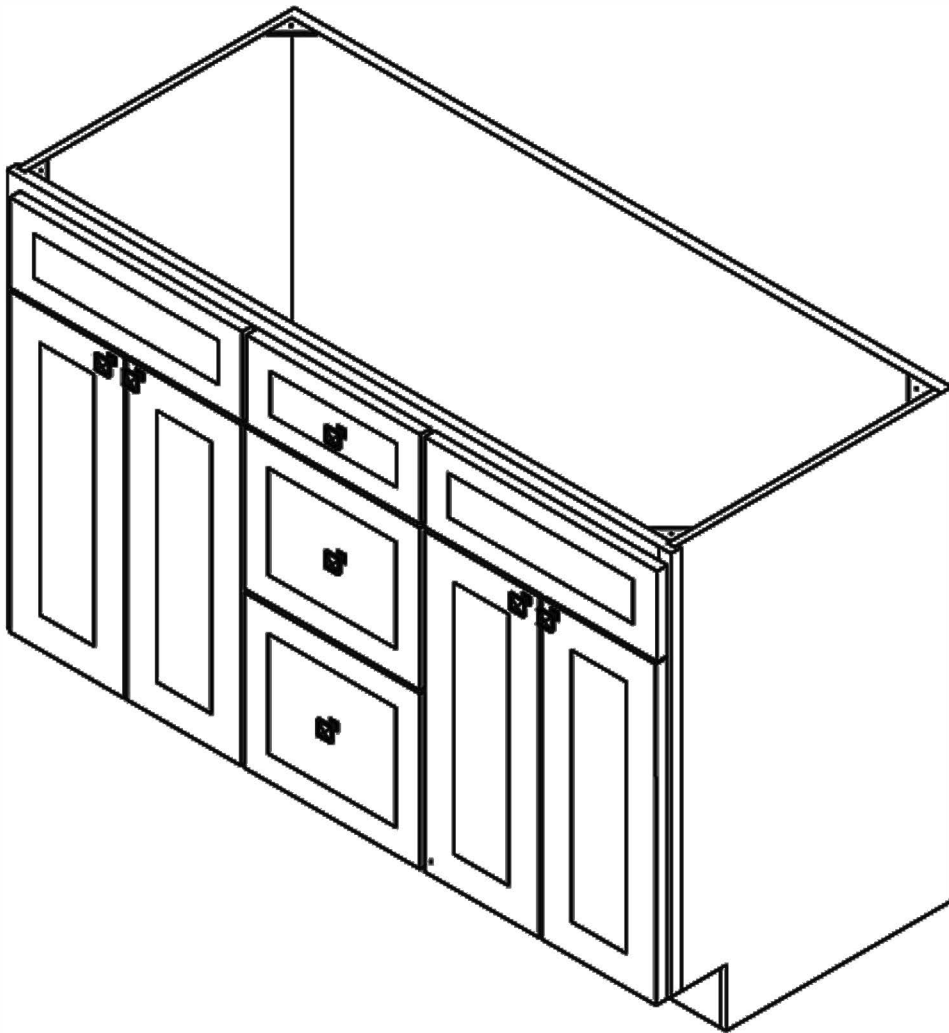

Part#: 599019-WHT, 599019-GRY  
599019-MBH, 599019-ESP

## ASSEMBLY INSTRUCTIONS

Four Door Three Drawer Vanity Base Cabinet



## Unpacking Precautions

If using a sharp object to unpack the vanity components and the packing materials, be careful to avoid scratching or damaging the vanity components. The various packing materials are used to protect the vanity components during shipping. During the unpacking process, place the various components away from and to the side of the work area so that they will not be inadvertently knocked over or otherwise damaged.

## Required Tools

Phillips Screwdriver

Rubber Mallet

Wood Glue



# PARTS LIST

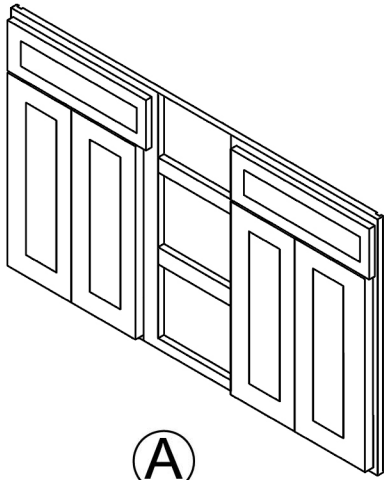

(A)

FRONT PANEL 1PC

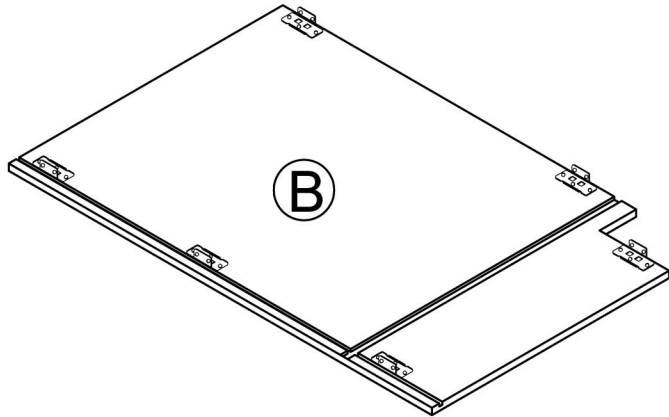

(B)

RIGHT SIDE PANEL 1PC

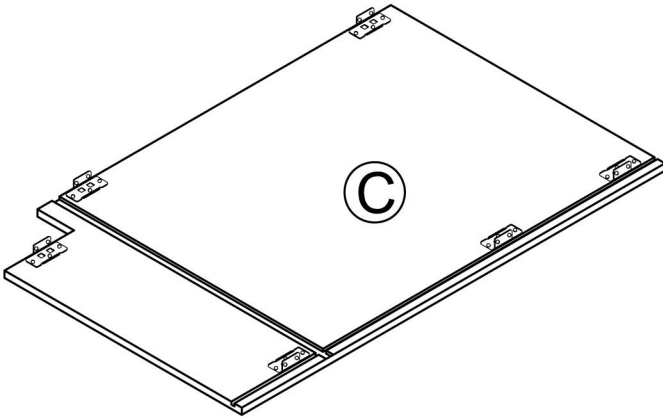

(C)

LEFT SIDE PANEL 1PC

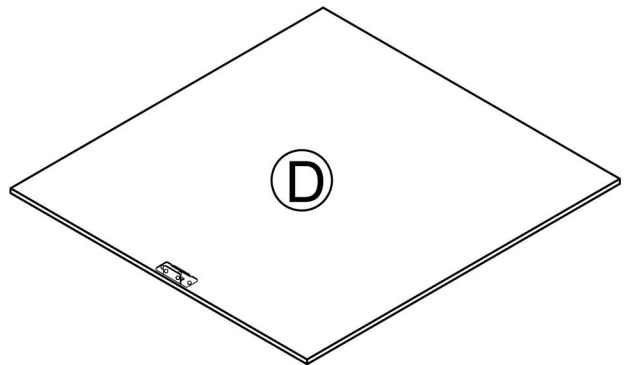

(D)

BOTTOM PANEL 1PC

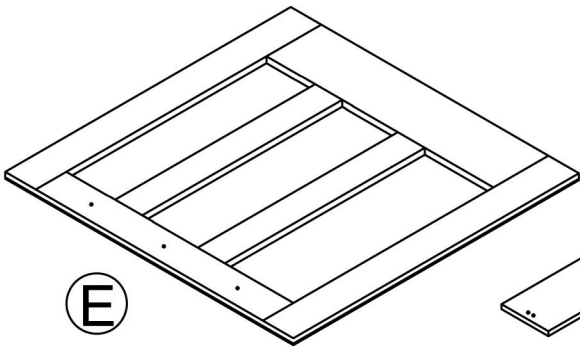

(E)

BACK PANEL 1PC

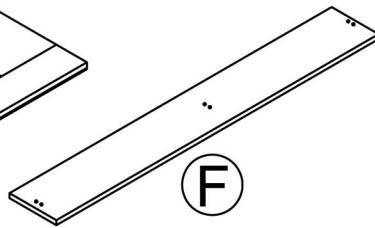

(F)

TOE KICK 1PC

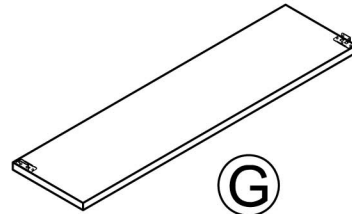

(G)

SUPPORT PANEL 1PC

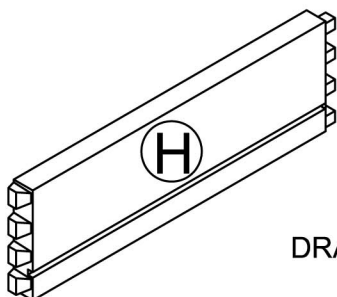

(H)

DRAWER SIDE PANEL 6 PCS

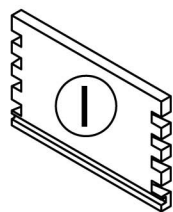

(I)

DRAWER BACK PANEL 3PCS

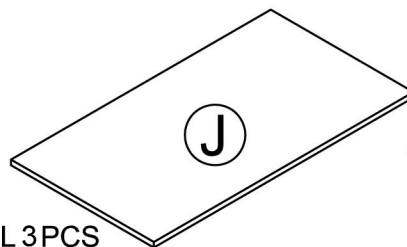

(J)

DRAWER BOTTOM PANEL 3PCS

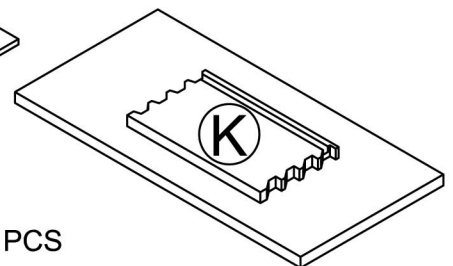

(K)

DRAWER FRONT PANEL 3PCS

# HARDWARE LIST

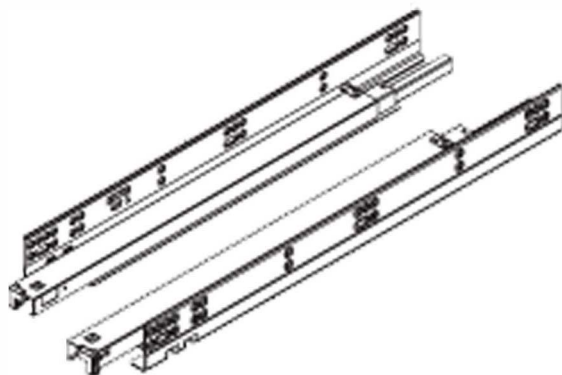

a. UNDERMOUNT SOFT CLOSE GLIDE(L/R)



b. PLASTIC CLIP(L/R)



c. KNOB 7PCS

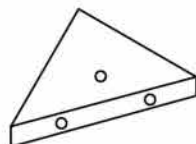

d. WOODEN TRIANGLE 4PCS



e. RUBBER BUMPER 20 PCS



f. GLIDE BRACKET 6 PCS

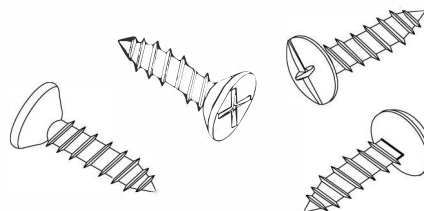

g. 1/2" FLAT (ROUND)HEAD SCREW 28PCS  
ROUND HEAD SCREW FOR ESPRESSO METAL CLIP ONLY

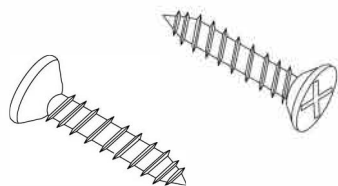

h. 7/8" FLAT HEAD SCREW 8PCS

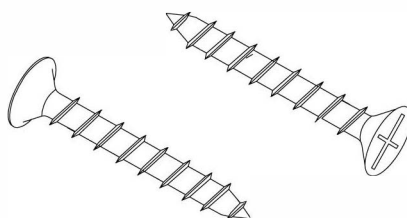

i. 1-1/8" FLAT HEAD SCREW  
7PCS (3 PCS FOR ATTACHING  
THE BACK PANEL TO THE  
BOTTOM PANEL, 4PCS FOR  
CONNECTING TO THE  
COUNTERTOP)

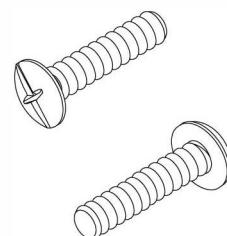

j. KNOB SCREW FOR DOOR 1" 4PCS

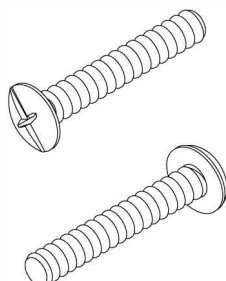

k. KNOB SCREW FOR DRAWER 1-5/16" 3PCS

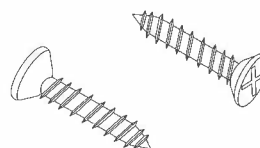

l. 3/5" GLIDE SCREW 36 PCS

### Step 1

Lay the face frame with doors (A) on a soft surface, doors facing down.

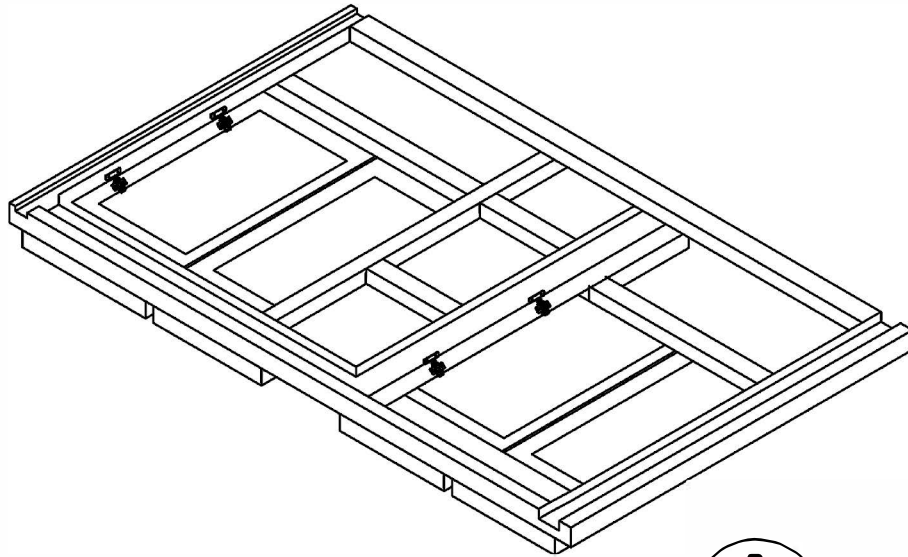

### Step 2

Attach rubber bumpers to both the top and bottom of each door where they make contact with the face frame to prevent damage and reduce noise.

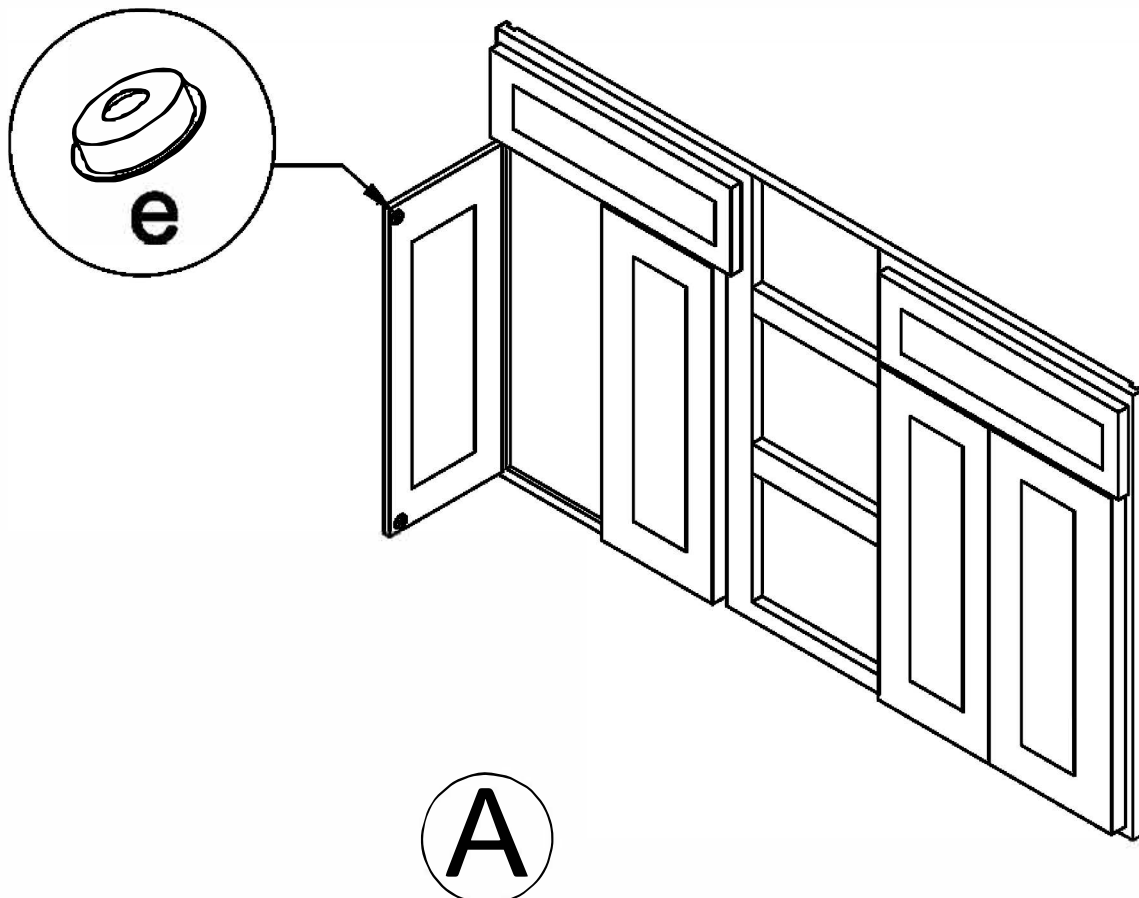

### Step 3

Using the wood glue, squeeze a small bead of glue in all grooves before assembling the cabinet sides, bottom, top and back panels. Be careful not to use too much glue, this could cause excess glue to squeeze out and onto the panels, if this should happen, be sure to remove quickly.

### Step 4

Slide the Right side panel (B) into the groove of the face frame, and mount the male clip to the face frame with the screwdriver. Each male clip will need 2 small screws (g).

Slide the Left side panel (C) into the Left groove of the face frame, and mount the male clip to the face frame with a screwdriver. Each male clip will need 2 small screws (g).

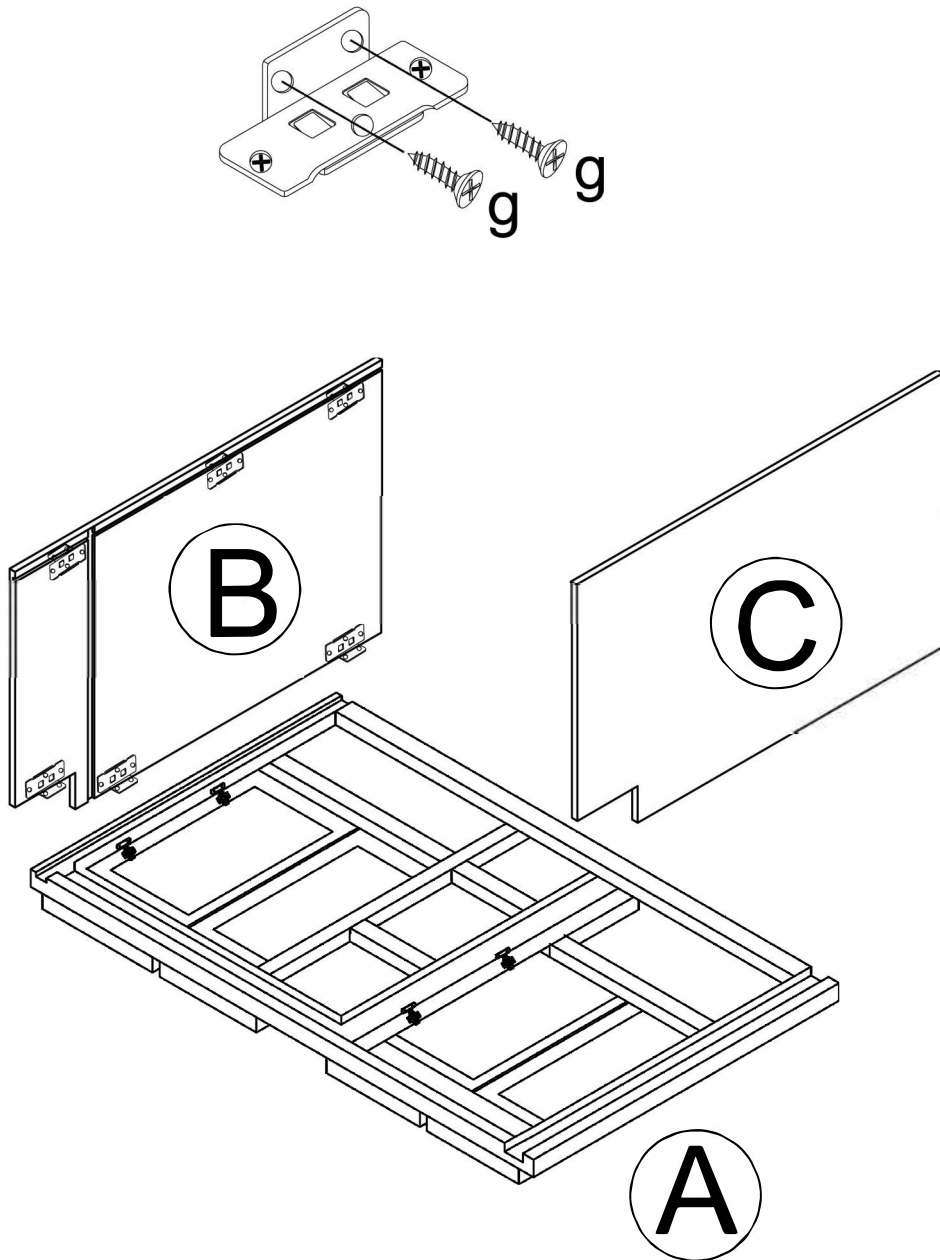

## Step 5

Slide bottom panel (D) into the groove of the right and left side panels, and then into the groove in the frame below until it is fully seated. Slide in the back panel (E) and attach the male clips to the back panel. There are three clips on the left side and three clips on the right side. Each male clip will need 2 small screws (g).

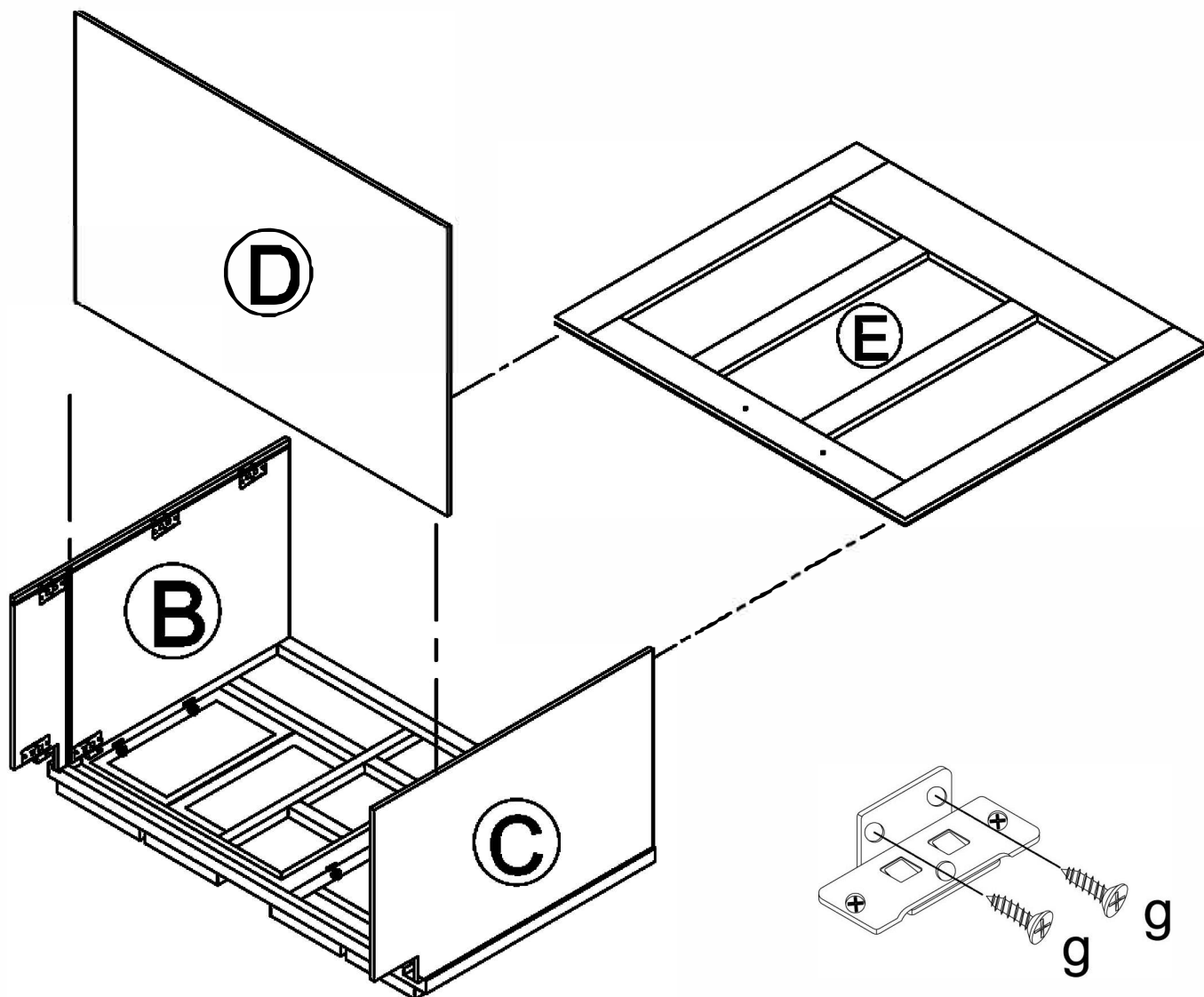

## Step 6

Use the long screws (i), attach the back panel to the edges of the bottom panels, using the pre-drilled holes provided. Secure the toe kick (F) into the bottom of the cabinet, two small screws (g) in each of the two clips.

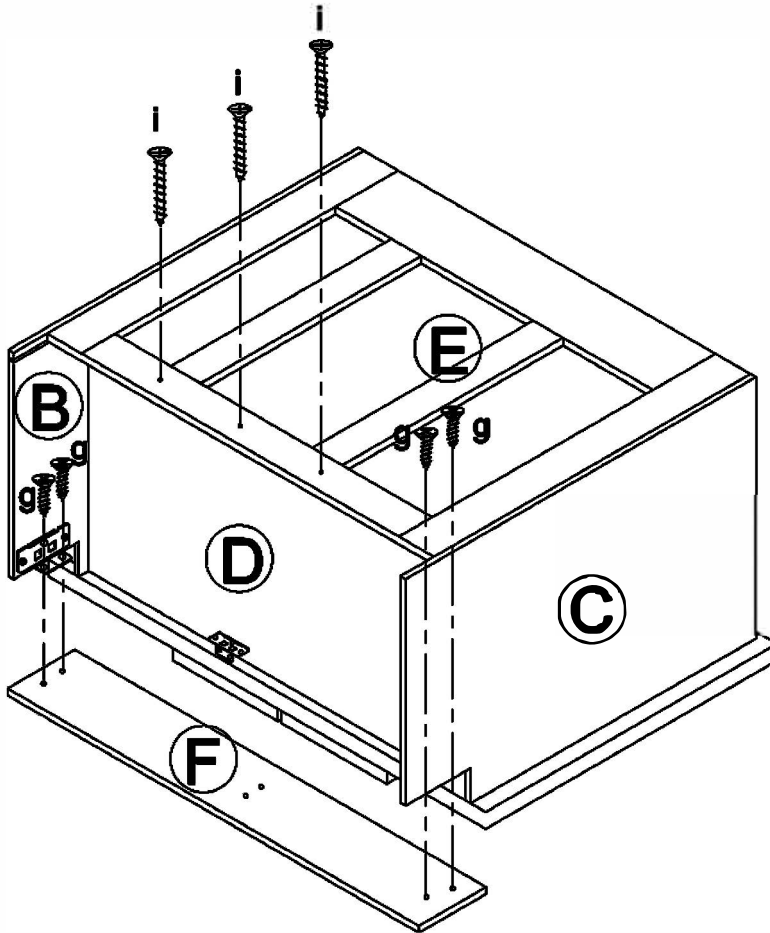

## Step 7

Secure the support panel (G) under the bottom panel using a male clip and two screws.

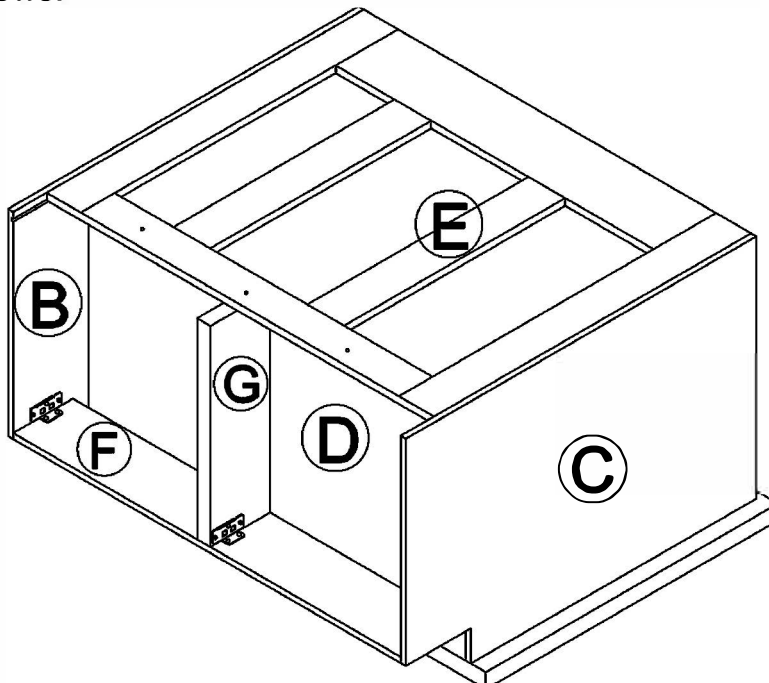



## Step 8

Align the dovetails of one of the drawer side panels (H) with the teeth on the drawer back panel (I) and gently seat the drawer side panel into the drawer back panel. This can be done by gently tapping the side with a rubber mallet.

Repeat this procedure for the second drawer side panel.

Slide the drawer bottom into the grooves on the sides and drawer back panel until it is fully seated.

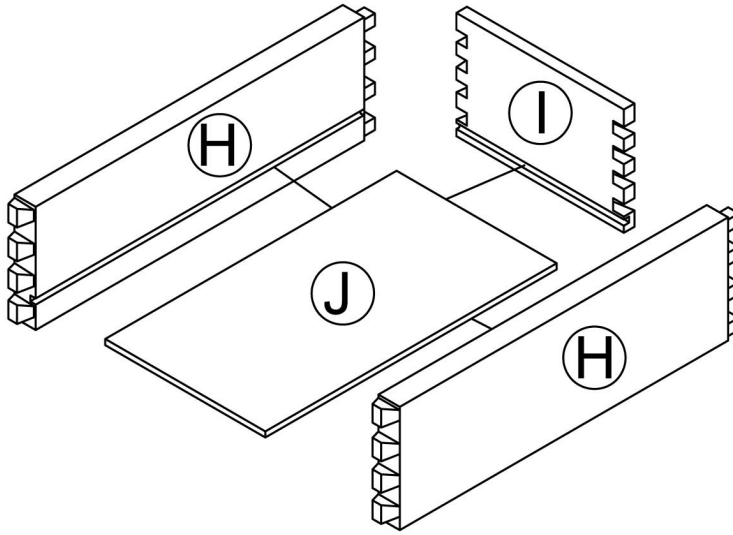

## Step 9

Attach the drawer fronts (K) to the drawer box by aligning the dovetails of drawer panels with the teeth on the front drawer panel (K) and gently seat as below.

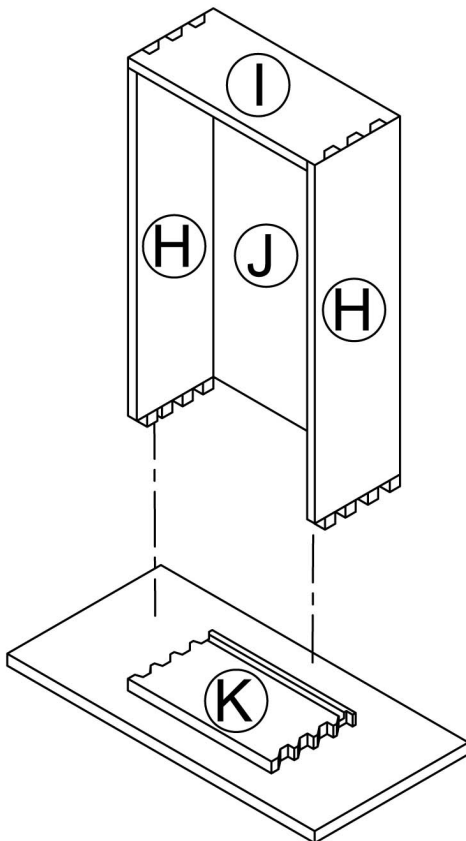

## Step 10

Attach the plastic clips on the bottom of the drawer, using six small flat head screws(L), three screws for each.

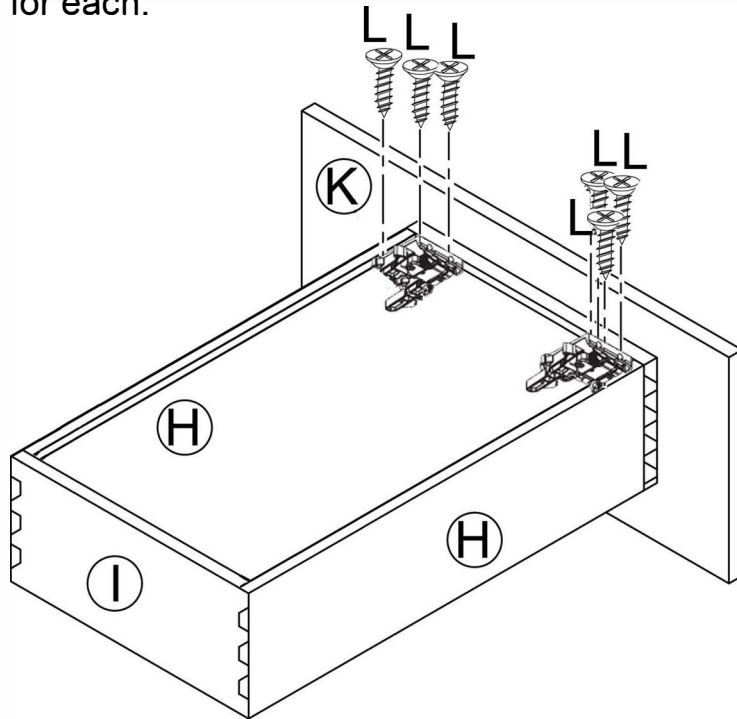

## Step 11

Use two small screws(L) to attach the glide bracket to the interior sets of pre-drilled holes on the back panel. Use one small screw(L) to attach the glide on the face frame. Install the drawers into the cabinet.

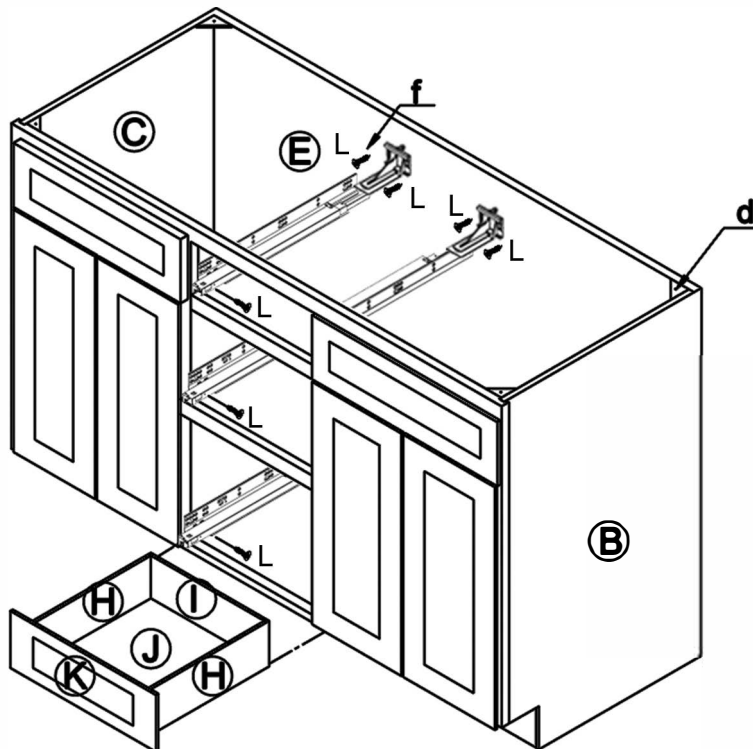

## Step 12

Install knobs (c). Pilot holes are provided on the back of the doors. If this is your desired location, use a drill to complete drilling the holes through the door, then install the knobs (c) with screws (k) provided.

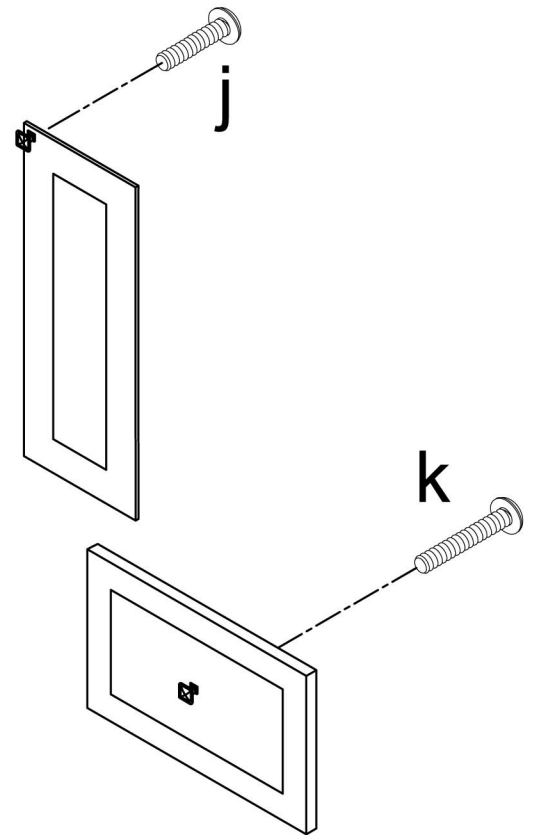
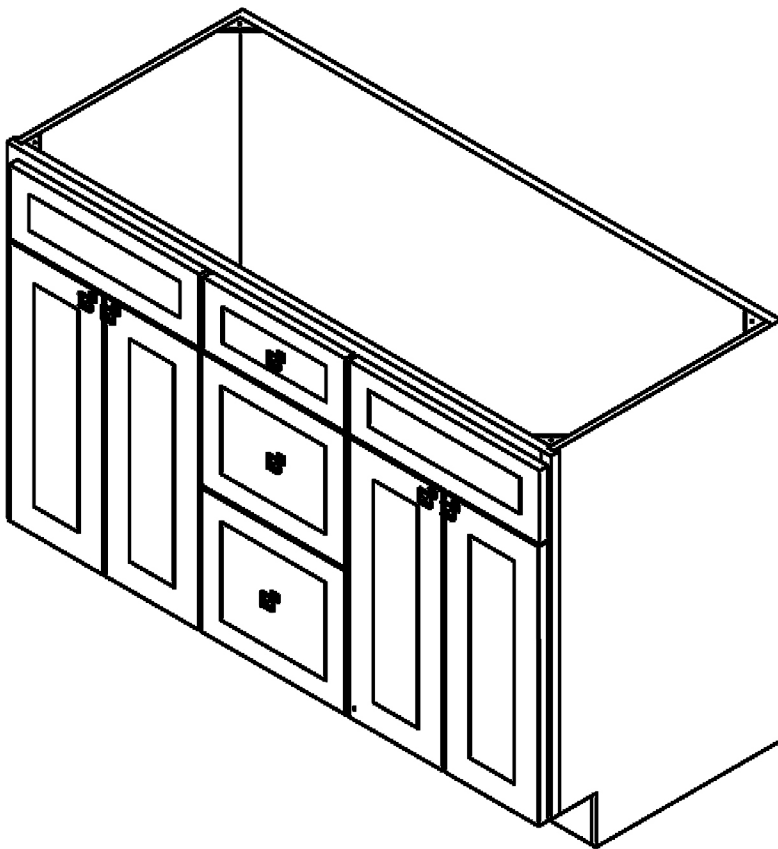

### Step 13

Use two middle size screws (h) to attach 4 wooden triangle blocks (d) in all four corners of the top of the cabinet.

