

Savannah I-Light Pendant Light
White and Polished Chrome

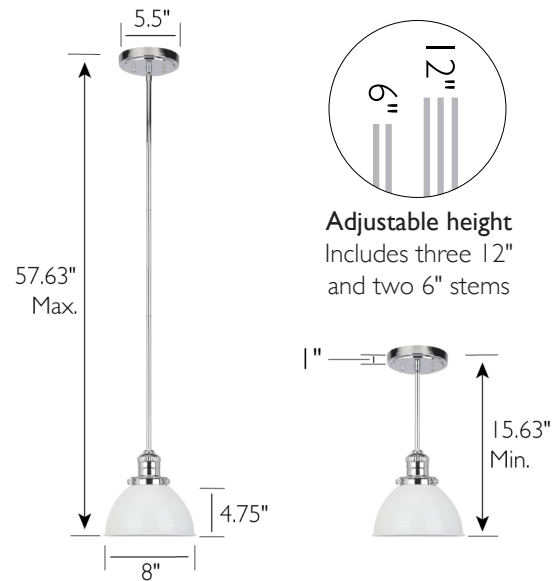
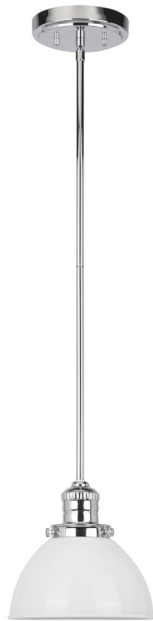

SPECIFICATIONS

MOUNTING:	Pendant	LED BRIGHTNESS (LUMENS):	N/A
SLOPED CEILING ADAPTABLE:	Yes	LED COLOR CORRELATED TEMPERATURE (CCT):	N/A
LAMP TYPE 1:	Incandescent	LED COLOR RENDERING INDEX (CRI):	N/A
BULB INCLUDED:	No	LED EFFICACY:	N/A
WATTS PER BULB:	60W	LED AVERAGE RATED LIFE:	N/A
TOTAL WATTAGE:	60W	ENERGY EFFICIENT:	No
DIMMABLE:	Yes	LIGHTING AMPS:	0.5
MATERIAL CONSTRUCTION:	Steel	VOLTAGE:	120V
ASSEMBLED DIMENSIONS:	57.63" H x 8" L x 8" D		
WEIGHT:	2.31 lbs.		
BACKPLATE DIMENSIONS:	N/A		
CANOPY/PLATE DIMENSIONS:	1" H x 5.5" W x 5.5" D		
GLASS/SHADE DIMENSIONS:	4.75" H x 8" L x 8" D		
GLASS/SHADE MATERIAL:	Metal		
GLASS/SHADE TYPE:	Metal		
GLASS/SHADE COLOR:	White		

WARRANTY:	10-Year limited warranty
UL/ETL CERTIFICATION:	UL
WET/DRY/DAMP LISTING:	Dry
ADA COMPLIANT:	No
ENERGY STAR CERTIFIED:	No



TYPE:
JOB:
ORDER CODE:
APPROVALS: