

## Millbridge Toilet Paper Holder with Shelf Oil Rubbed Bronze

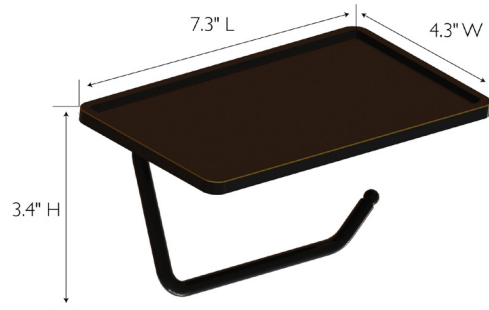
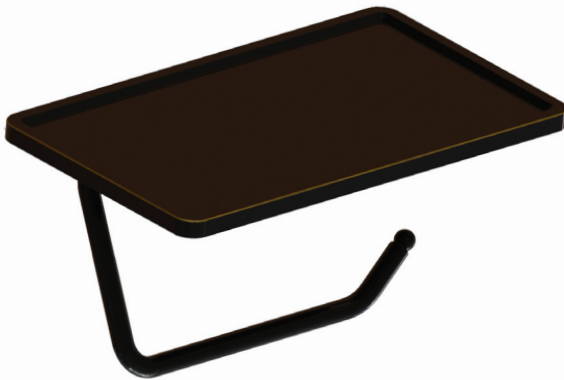

### SPECIFICATIONS

MATERIAL CONSTRUCTION:	Iron
ASSEMBLY REQUIRED:	No
TOOLS NEEDED FOR INSTALLATION:	Screwdriver
ASSEMBLED DIMENSIONS:	3.4" H x 7.3" L x 4.3" W
ASSEMBLED WEIGHT:	.93 lbs.
MIN. LENGTH:	7.3"
MAX LENGTH:	7.3"
SCREWS INCLUDED:	Yes
DRYWALL ANCHORS INCLUDED:	No

WARRANTY:	1-Year limited warranty
LEGAL FOR SALE IN CALIFORNIA:	Yes
ADA COMPLIANT:	N/A



TYPE:  
JOB:  
ORDER CODE:  
APPROVALS: