

### 2-Way Adjustable Eastport Entry Lever Satin Nickel

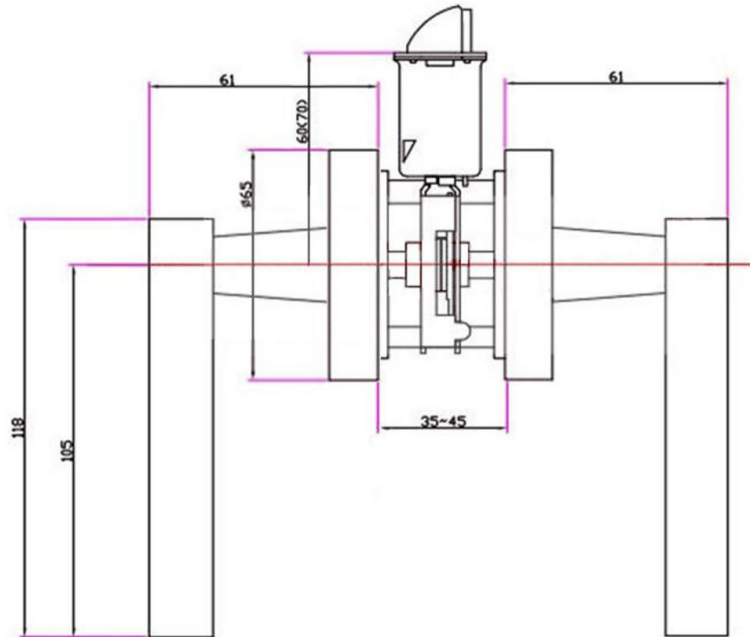

## SPECIFICATIONS

<b>MATERIAL CONSTRUCTION:</b>	Zinc	<b>KEYWAY:</b>	KW
<b>LOCK FUNCTION:</b>	Entry Knob/Lever	<b>REMOVABLE CORE:</b>	No
<b>DEADBOLT FUNCTION:</b>	N/A	<b>LATCH FACEPLATE I:</b>	Round Corner
<b>EXTERIOR MAX PROJECTION:</b>	2.4"	<b>LATCH BACKSET:</b>	Adj; 2-3/8" - 2-3/4"
<b>INTERIOR MAX PROJECTION:</b>	2.4"	<b>LATCH TYPE:</b>	2 Way (fixed faceplate)
<b>KOB VS. LEVER:</b>	Lever	<b>LATCHBOLT THROW DISTANCE:</b>	0.5"
<b>KNOB DIMENSIONS:</b>	N/A	<b># PINS IN CYLINDER:</b>	5
<b>LEVER LENGTH:</b>	4.65"	<b>ANTI-BUMP PIN INSTALLED:</b>	Yes
<b>ROSE DIMENSIONS:</b>	2.56" H x 2.56" W x 2.56" D	<b># KEYS INCLUDED:</b>	2
<b>ROSETTE / ESCUTCHEON SHAPE:</b>	Round	<b>SPINDLE TYPE:</b>	Square
<b>CROSS BORE:</b>	2.13"	<b>MOUNTING HARDWARE INCLUDED:</b>	Yes
<b>EDGE BORE:</b>	1"	<b>TOOLS NEEDED FOR INSTALLATION:</b>	Phillips Screwdriver
<b>HANDING:</b>	Reversible	<b>ASSEMBLED WEIGHT:</b>	N/A
<b>REKEYABLE?:</b>	Yes		

<b>WARRANTY:</b>	5-Year limited warranty
<b>ANSI CERTIFICATION:</b>	Grade 3
<b>BHMA GRADE:</b>	3
<b>FIRE RATED:</b>	No
<b>ADA COMPLIANT:</b>	No



TYPE:
JOB:
ORDER CODE:
APPROVALS: