



Design House is a registered brand of DHI Corp.

Mequon, WI 53092
1-800-558-8700

HATHAWAY SINGLE HANDLE TUB & SHOWER FAUCET

Models 545640, 545632
545624

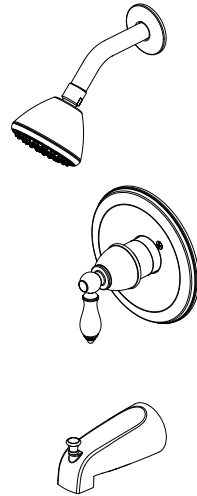

Your new Design House faucet will give you years of trouble free performance. Thank you for choosing our product for your home. **Please read all of these instructions carefully before installing your new faucet.**

Helpful tools to install this faucet:

- basin wrench
- Teflon tape
- (2) crescent wrenches
- silicon sealer
- flashlight
- faucet supply tubes

IMPORTANT POINTS

- When installing your new faucet, hand tighten the connector nuts, then use one wrench to anchor the fitting and a second wrench to tighten the nut one additional turn. Connections that are too tight will reduce the integrity of the system.
- Wrap threaded connections (except aerator thread in spout or where o-ring or rubber sealant are present) with Teflon tape available from your local hardware or plumbing supply store. Always wrap in a clockwise direction.

SAFETY TIPS

- **ALWAYS** protect your eyes with safety glasses.

INSTALLATION PROCEDURE

1. Shut off the water supply to the tub and shower. Verify that the hole sizes and positions of the holes in the wall are correct:
a. The shower and tub spout outlet holes should be 1-1/4 in. diameter.
b. The valve access hole should be 6 in. diameter.
c. The recommended valve depth to the finished wall is 2 in. min. to 2-1/2 in. max. Ensure that the valve body (1A) cover is flush with the finished exterior surface of the wall. Position the valve body (1A) correctly in the wall with the "UP" pointing up. The 8 in. minimum from the valve body to the tub spout is required for proper operation.

2. Unscrew the screws (2A), and remove the plaster guard (2B).

3. TUB & SHOWER OUTLET CONNECTIONS
Wrap thread sealant tape around the pipe threads in a clockwise direction, as shown. Connect the hot and cold water supply lines (3A, not included), the shower (3B, not included) and tub outlet pipes (3C, not included) to the valve body (3D). Connect the pipe elbows (3E, not included) to the ends of both pipes, and tighten with a wrench.
Note: a. Be sure to position the body (3D) correctly in the wall, with the markings "UP" facing upward.
b. The hot water supply lines go into the H inlet, and the cold water supply lines go into the C inlet.
c. Do not use PEX or CPVC between the valve and spout.

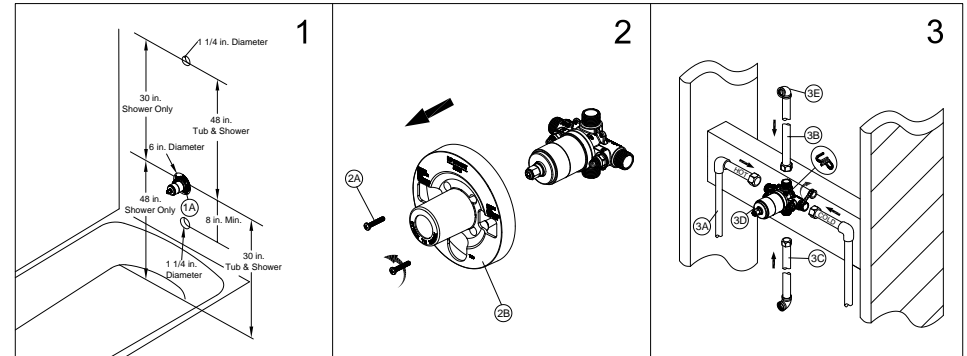

4. SHOWER ONLY OUTLET CONNECTIONS
Wrap thread sealant tape around the pipe threads in a clockwise direction, as shown. Connect the hot and cold water supply lines (4A, not included), the shower outlet pipe (4B, not included) to valve body (4C). Wrap thread sealant tape around the threads of the plug (4D), and insert it into the bottom outlet (4E). Connect the pipe elbows (4F, not included) to the end of the pipe, and tighten with a wrench.
Note: a. Be sure to position the body (4C) correctly in the wall, with the markings "UP" facing upward.
b. The hot water supply lines go into the H inlet, and the cold water supply lines go into the C inlet.

5. FLUSHING
Place the handle (5A) on the valve body inverter (5B) and turn the handle (5A) to the full on mixed position. Turn on the hot and cold water supply lines and allow the water to flow from the outlets for one minute, or until all foreign matter has been flushed out. Check for leaks. Shut off the water at the faucet and supply lines. Remove the handle (5A) and unscrew the screw (5C).

6. Place the plaster guard (6A) onto the body (6B) and secure with the screws (6C).

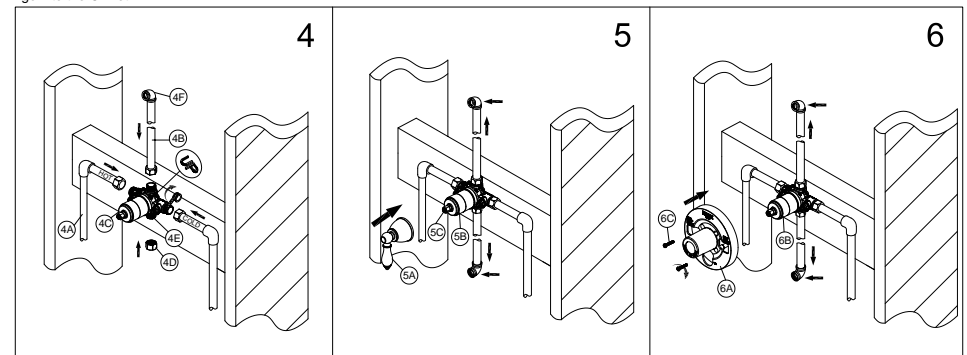

INSTALLATION PROCEDURE

7. SHOWER FLANGE AND SHOWER ARM INSTALLATION

Insert the long end of the shower arm (7A) through the flange (7B), then wrap thread sealant tape around long end of the shower arm (7A) in a clockwise direction, as shown. Install the long end of the shower arm (7A) into the pipe elbow inside the wall. Tighten the shower arm (7A), do not over tighten. Wrap thread sealant tape around the pipe threads of the tub spout outlet (7C, not included) in a clockwise direction, as shown. Connect the tub spout outlet pipe (the tub spout outlet pipe should project 3-7/8 in. to 4-1/16 in. from the finished wall) to the lower pipe elbow (7D, not included). Tighten the elbow and tub spout outlet pipe connections with a wrench.

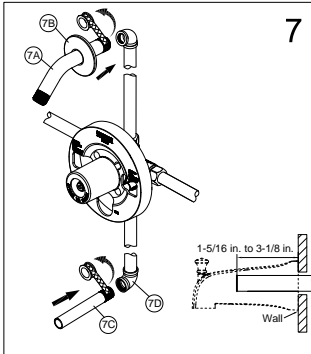

8. FOR TUB SPOUT INSTALLATION

Place the spout (8A) onto quick connection until the spout (8A) becomes flush with the finished wall and tighten the screw (8B) with the Hex wrench (Hex: 3.97mm) provided.

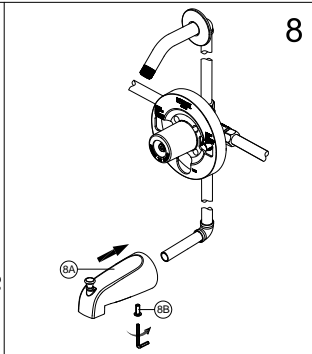

9. Before installing the escutcheon, remove the plastic cap from the valve body (9A) by twisting the cap in a clockwise direction.

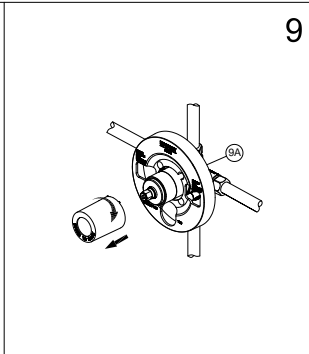

10. CHECKING FOR LEAKS

Place the handle (10A) on the valve body inverter (10B) and turn the handle to the full on mixed position. When the valve is turned on, water normally flows through the tub spout (10C). To activate the shower, turn the valve on and pull the knob (10D) up. Hold the knob (10D) until the water flows continuously from the shower arm (10E). Check for leaks. Shut off the water at the faucet and supply lines. Remove the handle (10A).

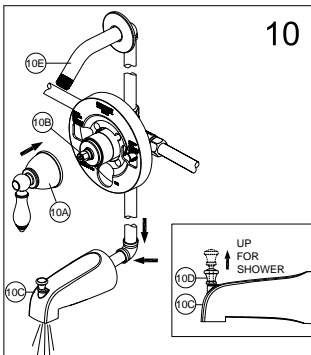

11. ESCUTCHEON, HANDLE AND SHOWER HEAD INSTALLATION

Install the escutcheon (11A) onto the valve body (11B) using the escutcheon screws (11C). Place the handle (11D) onto the valve body (11B) and secure it with the screw (11E). Use a Phillips screwdriver to tighten the screws. Insert the index (11F) into the handle (11D). Thread the shower head (11G) to the shower arm (11H).

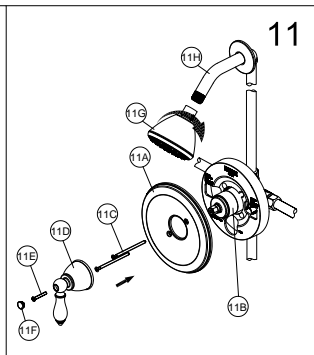

12. ADJUSTING WATER TEMPERATURE

Turn on water so that cold water is as cold as it will get and hot water is as hot as it will get. Remove the Rotational Limit Stop from the valve by sliding it off the stem. Place handle back on stem and rotate fully counterclockwise to the hottest position. Place a thermometer in a plastic tumbler and hold in the water stream. If the water temperature is above 120°F, the Rotational Limit Stop must be rotated counterclockwise to decrease temperature. Reinstall the stop by sliding it back on to the stem before reinstalling the handle. **MAKE SURE COLD WATER FLOWS FROM THE VALVE FIRST. MAKE SURE WATER (AT THE HOTTEST FLOW) DOES NOT EXCEED THE TEMPERATURE LIMIT ALLOWED BY YOUR PLUMBING CODES (120°F OR 110°F).**

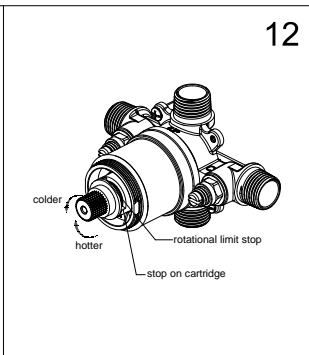

TROUBLE SHOOTING

- o 545640 - Polished Chrome
- o 545632 - Satin Nickel
- o 545624 - Oil Rubbed Bronze

Problem:

Leaks underneath handle.

Cause:

Bonnet has come loose or cartridge is dirty or broken.

Action:

Remove the handle. Tighten the bonnet. If water still does not completely shut off, turn off the water supply or turn off the stop valves. Replace the cartridge.

Many of these parts come preassembled. This exploded diagram is to assist in trouble shooting.

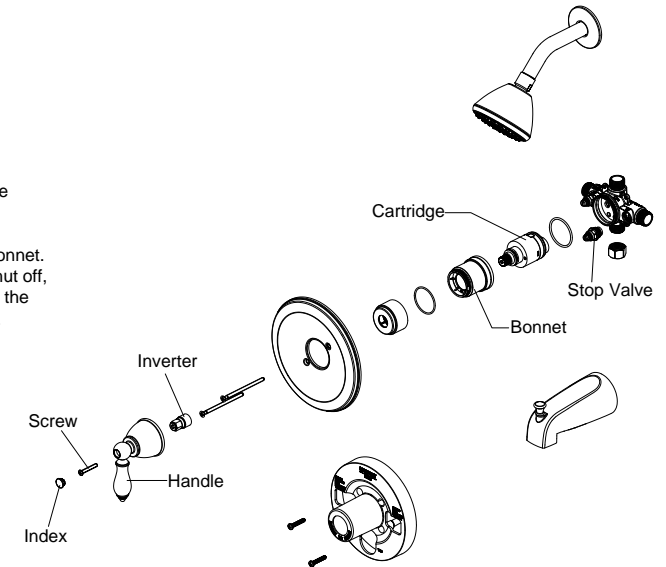

MAINTENANCE

Your new Design House faucet is designed to give you years of trouble free performance. Avoid abrasive cleaners, steel wool and harsh chemicals that will dull the finish and void your warranty.

Brass finishes are polished and in some cases, protected with a PVD finish or a durable lacquer coat, to prevent tarnishing.

Keep it looking like new by cleaning it periodically with a mild solution of soapy water. Rinse thoroughly and then dry with a soft cloth.

CONSUMER PROTECTION WARNING

Under the Safe Drinking Water Act, the U.S. Environmental Protection Agency restricts the amount of lead used in brass and solder. Your new faucet is made in strict compliance with all government standards. The materials used in the manufacture of this faucet are of industry standard quality and are similar to other plumbing products having brass fittings.

To reduce the amount of lead in your drinking water, allow the water to run for a moment before filling your glass and remember to always use cold water for drinking purposes.