



160 __ T90 __ Series

Write purchase model number here for future reference

Electronic Washdown Urinal

207738

207738

207738

207738

207738

207738

207738

207738

207738

207738

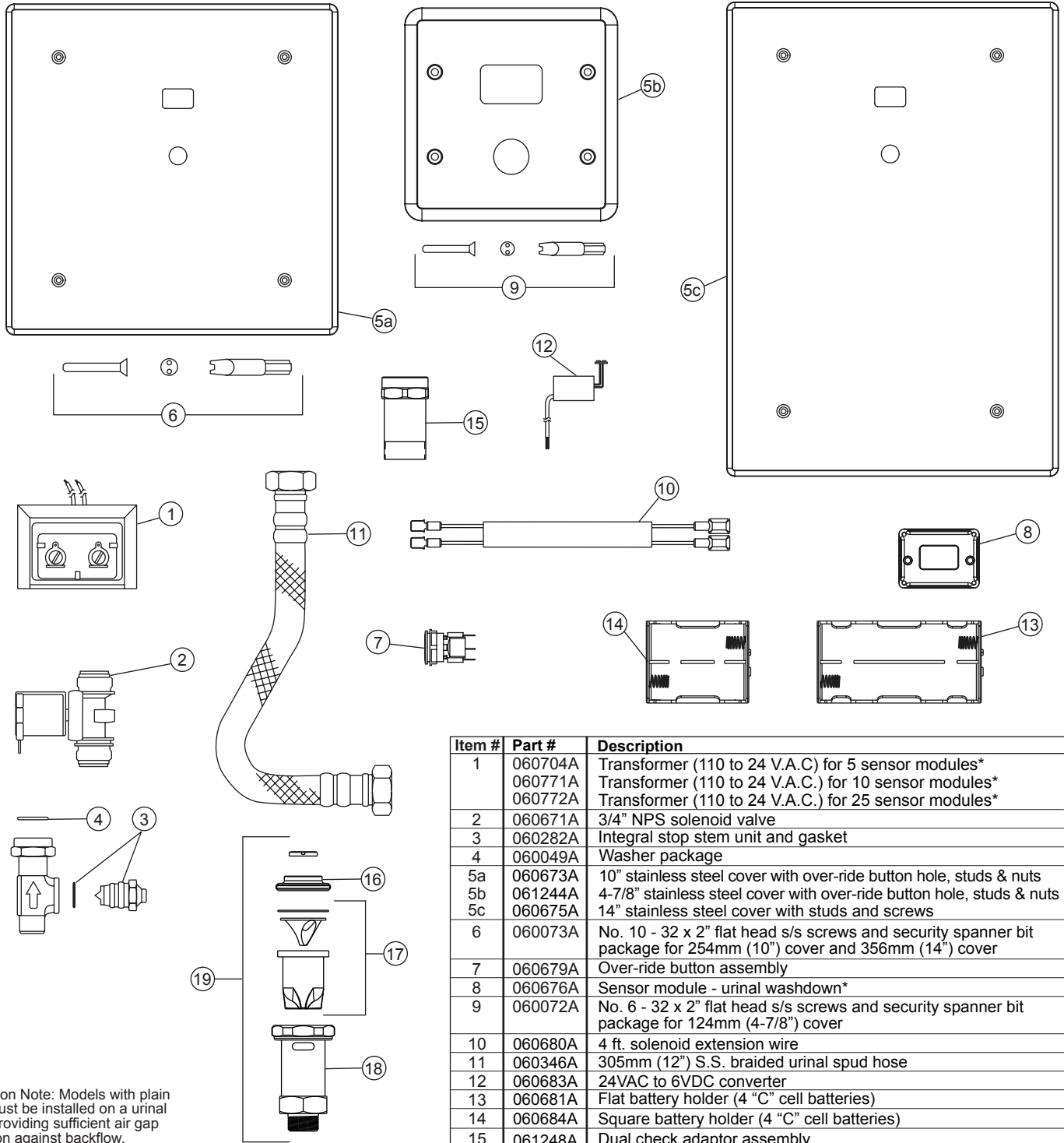

Installation Note: Models with plain outlet must be installed on a urinal fixture providing sufficient air gap protection against backflow.

PLEASE LEAVE this sheet with the owner, maintenance plumber, etc. as items relating to ongoing maintenance suggestions and procedures are included.

| Item # | Part # | Description |
|--------|-------------------------------|---|
| 1 | 060704A 060771A 060772A | Transformer (110 to 24 V.A.C) for 5 sensor modules* Transformer (110 to 24 V.A.C.) for 10 sensor modules* Transformer (110 to 24 V.A.C.) for 25 sensor modules* |
| 2 | 060671A | 3/4" NPS solenoid valve |
| 3 | 060282A | Integral stop stem unit and gasket |
| 4 | 060049A | Washer package |
| 5a | 060673A | 10" stainless steel cover with over-ride button hole, studs & nuts |
| 5b | 061244A | 4-7/8" stainless steel cover with over-ride button hole, studs & nuts |
| 5c | 060675A | 14" stainless steel cover with studs and screws |
| 6 | 060073A | No. 10 - 32 x 2" flat head s/s screws and security spanner bit package for 254mm (10") cover and 356mm (14") cover |
| 7 | 060679A | Over-ride button assembly |
| 8 | 060676A | Sensor module - urinal washdown* |
| 9 | 060072A | No. 6 - 32 x 2" flat head s/s screws and security spanner bit package for 124mm (4-7/8") cover |
| 10 | 060680A | 4 ft. solenoid extension wire |
| 11 | 060346A | 305mm (12") S.S. braided urinal spud hose |
| 12 | 060683A | 24VAC to 6VDC converter |
| 13 | 060681A | Flat battery holder (4 "C" cell batteries) |
| 14 | 060684A | Square battery holder (4 "C" cell batteries) |
| 15 | 061248A | Dual check adaptor assembly |
| 16 | 060513A | VB adaptor |
| 17 | 060785A | VB sleeve complete |
| 18 | 061249A | VB adaptor assembly |
| 19 | 061250A | VB assembly |

NOTE: Refer to TECK flushometer repair parts and maintenance manual for additional parts and information.

*Each individual sensor module requires its own 24VAC to 6VDC hardwire converter (see item #12).

ELECTRONIC WASHDOWN URINAL INSTRUCTIONS

STEP 1 – ROUGH IN

4" Sensor Plate Models

If Hardwire Operated

- 102mm (4") box is supplied, remove suitable knockouts and insert cable bushing as per Fig. 1A.
- Rough in box for sensor location as per Fig. 1B on centreline of fixture. **Note:** Solenoid extension cord supplied with the trim is 1220mm (48") long.
- Securely attach box to wall structure.
- Install and attach valve to water supply as per Fig. 1B.
- Install CSA and/or UL approved Class 2 transformer or equivalent in a convenient location or in a pipe chase. **(DO NOT install the transformer inside the control box.)**
- Run suitable wire from 24VAC power source into box. Use wire which complies with local electrical codes for 1 amp load No. 18 cable is usually sufficient.
- Attach supplied plasterguard as per Fig. 1B to ensure sensor mounting holes are positioned correctly.

4" Sensor Plate Models

If Battery Operated

- 102mm (4") box and 4" box extension is supplied. Remove suitable knock-out as per Fig. 1A.
- Attach box extension to front of the box.
- Rough in box assembly for sensor location as per Fig. 1B on centreline of fixture. **Note:** Solenoid extension cord supplied with the trim is 1220mm (48") long.
- Securely attach box to wall structure.
- Install valve box and attach valve to water supply as per Fig. 1B.
- Attach supplied plasterguard as per Fig. 1B to ensure sensor mounting holes are positioned correctly.

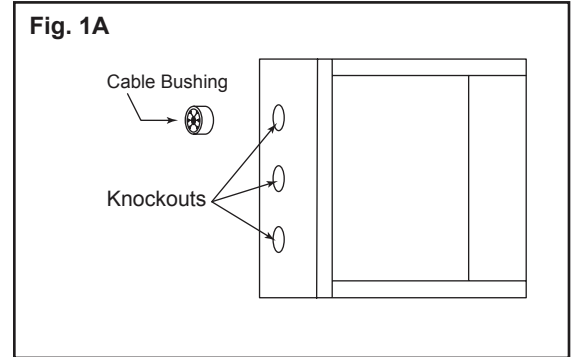
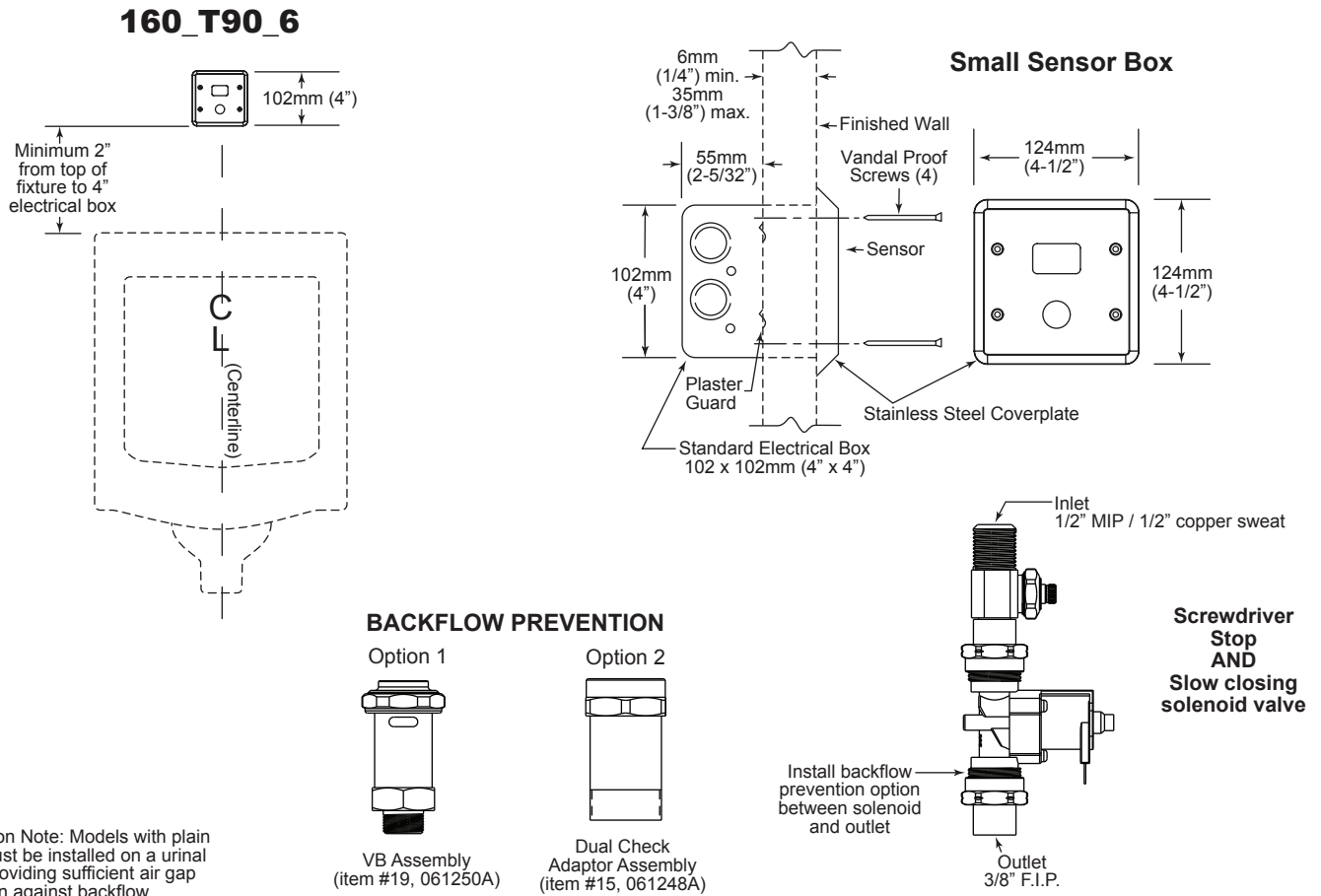

Fig. 1B



Installation Note: Models with plain outlet must be installed on a urinal fixture providing sufficient air gap protection against backflow.

ELECTRONIC WASHDOWN URINAL INSTRUCTIONS

STEP 1 – ROUGH IN (CONTINUED)

10" Sensor Plate Models

- 8" box is supplied. Rough in box flush to the wall, so the valve will be positioned as shown per Fig. 1C on centreline of fixture.
- Securely attach box to wall structure.

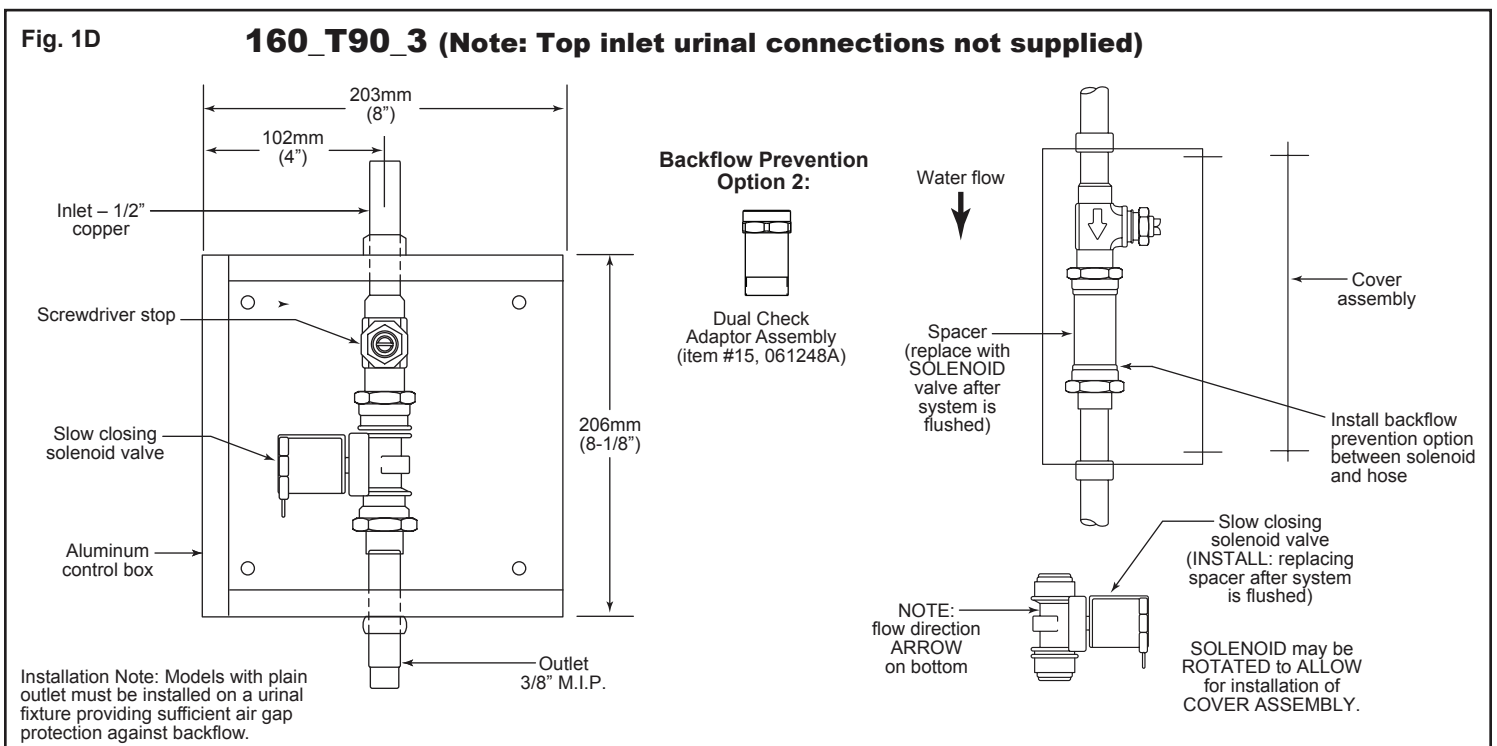
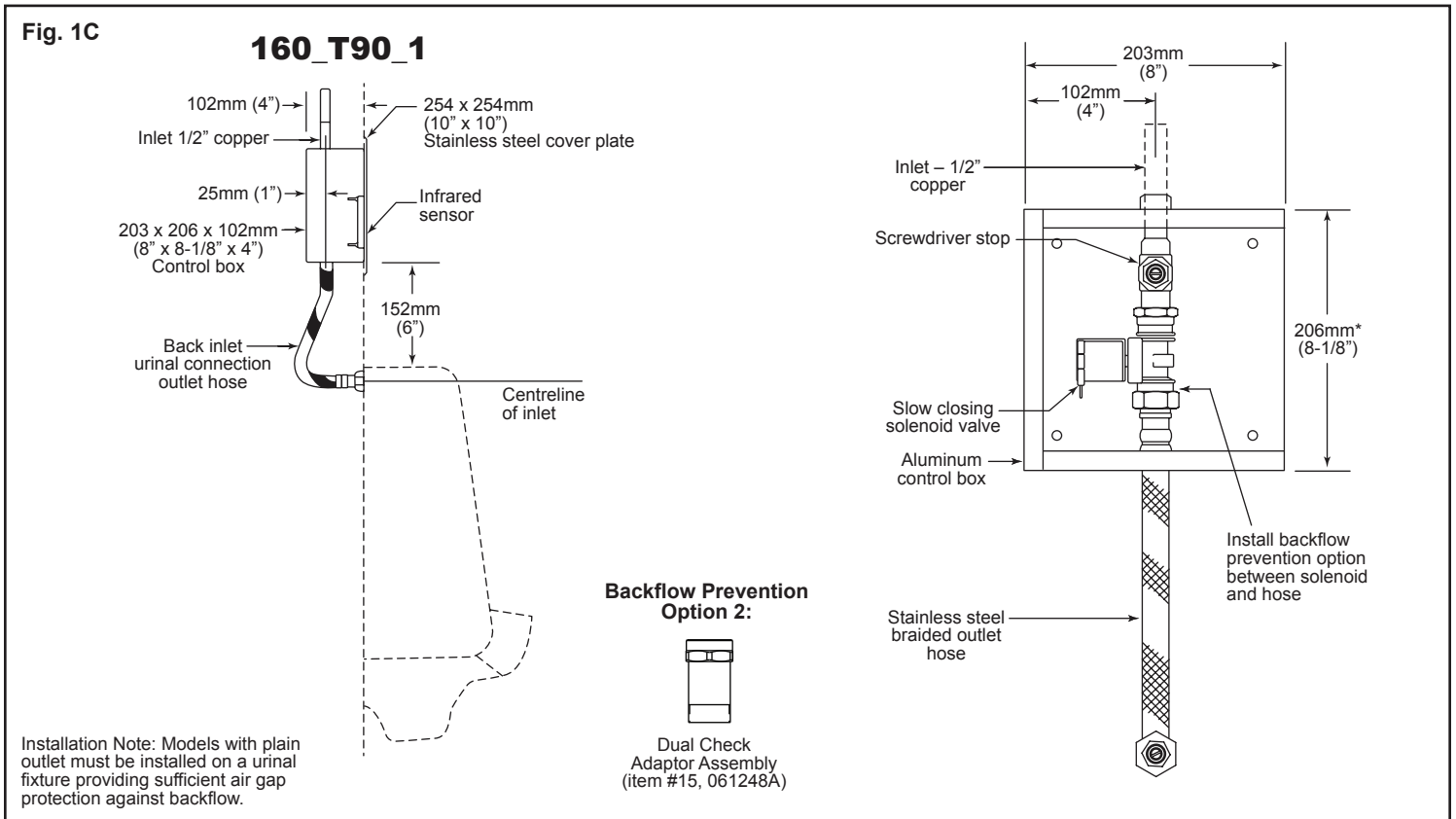

ELECTRONIC WASHDOWN URINAL INSTRUCTIONS

STEP 1 – ROUGH IN (CONTINUED)

14" Sensor Plate Models (Backflow Prevention Option 1: VB Assembly)

- 12" frame is supplied. Rough in frame so the solenoid valve will be positioned as shown in Fig. 1E.
- Securely attach frame to wall structure.

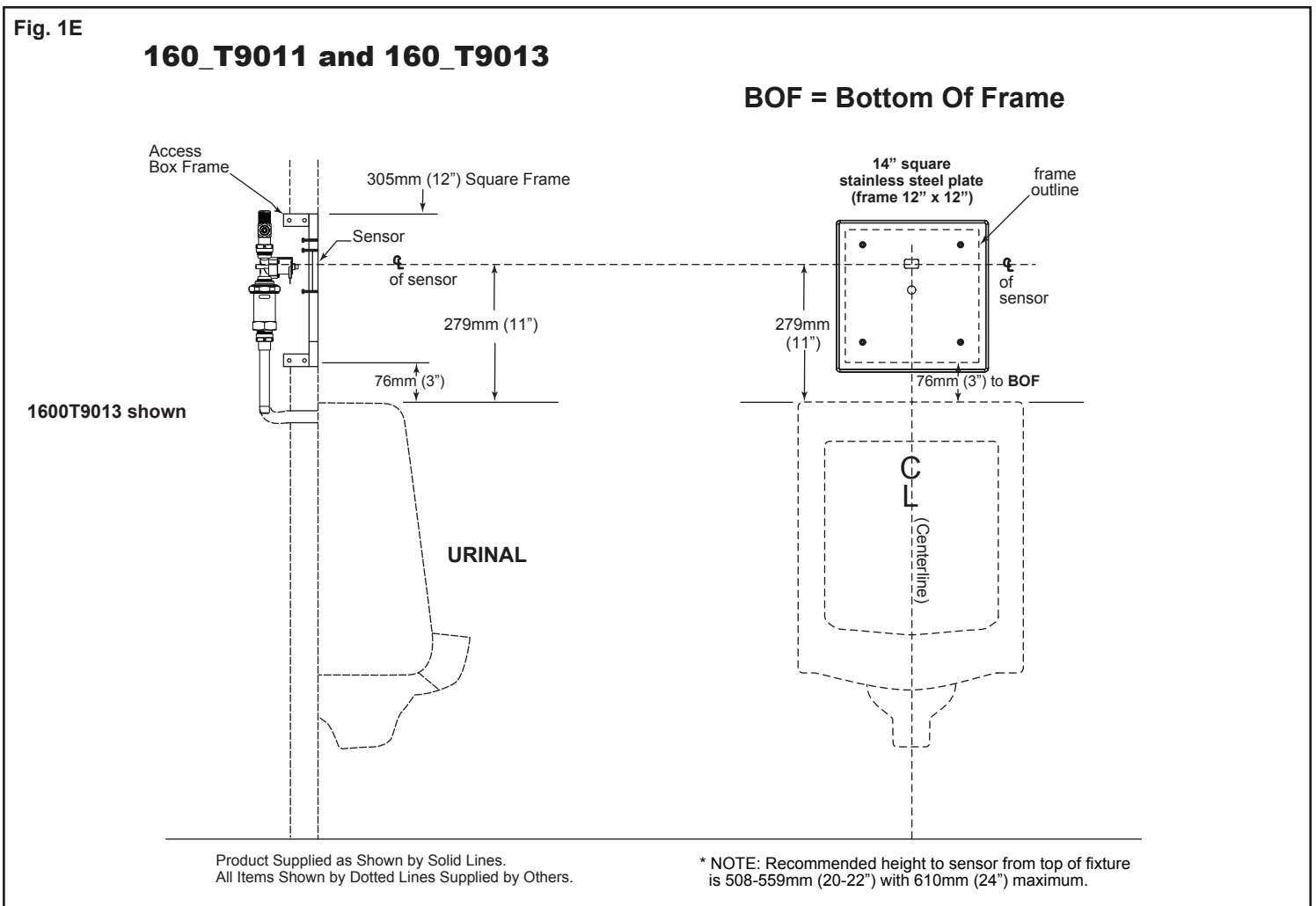

STEP 2 – INSTALL SENSOR PLATE

If Hardwire Operated

- Attach hardwire converter supplied to the 24VAC power source using the wire nuts provided.
- Attach converter to the sensor module using the snap connector. With power to flushometer, there will be a sequence of red lights that strobe across the sensing lens window which signifies that the valve is now in operation mode.

Fig. 2A

Solenoid Extension Wire

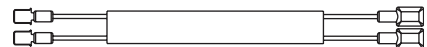

Factory pre-set functions are: Wash-down urinal sensing distance of 20", 24 hour flush is off, no flush delay and flush volume is 1.9L (0.5 U.S. gallons).

Once in operation mode, if adjustments are preferred, see Step 3 to make adjustments.

- 4" Plate Models - Using the 1220mm (48") solenoid extension cord supplied, attach the male tabs to the sensor module and the female connectors to the solenoid valve. Make sure to correctly match the wire colours on the sensor module and on the solenoid. Red wire attaches to the positive (+) tab which is marked on the solenoid coil.
- 10" Plate Models - Connect the female connectors from the sensor module to the solenoid on the flush valve. Make sure to correctly match the wire colours on the sensor module to the solenoid. Red wire attaches to the positive (+) tab which is marked on the solenoid coil.
- If the factory default settings for the sensor are not suitable, refer to step 3 for sensor adjustments.
- Attach sensor plate to the box using the 4 vandal proof screws provided.

ELECTRONIC WASHDOWN URINAL INSTRUCTIONS

STEP 2 – INSTALL SENSOR PLATE

If Battery Operated

- Install 4 “C” cell batteries provided into the battery holder and attach the holder to the sensor module using the battery clip. Use the +/- on the battery holder for correct positioning. With power to flushometer, there will be a sequence of red lights that strobe across the sensing lens window which signifies that the valve is now in operation mode.

Factory pre-set functions are:

Wash-down urinal sensing distance of 20”, 24 hour flush is off, no flush delay and flush volume is 1.9L (0.5 U.S. gallons).

Once in operation mode, if adjustments are preferred, see Step 3 to make adjustments.

- 4” Plate Models - Using the 1220mm (48”) solenoid extension cord supplied, attach the male tabs to the sensor module and the female connectors to the solenoid valve. Make sure to correctly match the wire colours on the sensor module and on the solenoid. Red wire attaches to the positive (+) tab which is marked on the solenoid coil.
- 10” & 14” Plate Models - Connect the female connectors from the sensor module to the solenoid on the flush valve. Make sure to correctly match the wire colours on the sensor module to the solenoid. Red wire attaches to the positive (+) tab which is marked on the solenoid coil.
- If the factory default settings for the sensor are not suitable, refer to step 3 for sensor adjustments.
- 4” Plate Models - Install battery holder into the back of the box and attach the sensor plate to the box using the 4 vandal proof screws provided.
- 10” & 14” Plate Models - Attach battery holder with the 2 way tape provided, to a secure location on the wall framing, etc.

STEP 3 - MAKING ADJUSTMENTS (OPTIONAL)

(Optional: Only required if factory settings are not preferred)

- To move from operation mode into set-up mode: remove the plastic plug located in the rear of the sensor module and press the set-up mode button once. A pencil or small screwdriver may be required. Once done, place the plug back in the hole.

Pre-set sensing distances are:

| Wash-Down Urinal | |
|------------------|-------------------|
| 1 light | 12” |
| 2 lights | 16” |
| 3 lights | 20” (factory set) |
| 4 lights | 24” |
| 5 lights | 28” |

3.1 Adjusting Sensing Distances:

- Sequences of red lights will intermittently strobe across the sensor window, followed by a number of red lights which stay on to indicate the current sensing distance.
- A pulsating blue light on the far left of the sensor window will indicate if an object is detected. However, the sensing distance could be set at a distance greater or shorter than the desired activating position.
- To ensure sensing distance is set to precise desired position, stand at desired activating distance.
- If the pulsating blue light is not present, press the override button (the red lights will increment).
- Continuing to press the override button will eventually loop the sensing distance back to 1 light (12” sensing distance).
- Press override button until pulsating blue light is present. The blue light indicates that the sensing distance has been adjusted to a position that is detecting you.
- The sensing distance for washdown urinals can be set between 12” and 28”.
- If all adjustments have been completed, press and hold down the manual override button for 5 seconds. This will advance the distance adjustment mode into the Flush Times adjustment mode.

3.2 Adjusting Flush Time/Volume:

- The blue light on the far left hand side of the sensor window will stay on, and 3 red lights will be present on the far right (factory set).
- To increment the flush time, press and release the override button once. The red lights will increment by one.
- A maximum of 5 lights may be obtained. Continuing to press the override button will eventually loop the flush time back to 1 light (4 second flush time).
- If all adjustments have been completed, press and hold down the manual override button for 5 seconds. This will advance the Flush Time adjustment mode into the 24 Hour Flush adjustment mode.

Pre-set flush times are:

| Wash-down Urinal Flush Times & Volume | | |
|---------------------------------------|-------------|-------|
| 1 light | 4 seconds | 1.9L |
| 2 lights | 3.6 seconds | 1.7L |
| 3 lights | 3.2 seconds | 1.5L |
| 4 lights | 7.8 seconds | 3.6L |
| 5 lights | 7.5 seconds | 3.45L |

3.3 Adjusting 24 Hour Flush:

- When 3 red lights in the centre of the sensor window are on, 24 hour flush is on.
- When the red light in the middle of the 3 lights is off, the 24 hour flush is off.
- Press manual override button to toggle between on and off mode.
- If all adjustments have been completed, press and hold down the manual override button for 5 seconds until all lights go out.

FUNCTION AND TROUBLESHOOTING LIGHTS

BATTERY VERSION: NO LIGHTS-NO POWER

Check that the 4 "C" batteries are positioned properly in the battery holder. Use the +/- on the battery holder for correct positioning. If the batteries are positioned correctly but there are still no lights, replace with 4 new "C" Alkaline batteries.*

HARDWIRE VERSION: NO LIGHTS-NO POWER

Check that the 24VAC transformer has power on the incoming 120VAC side. (Transformer breaker is turned on.)

Check the connection of the flushometer wires to 24VAC transformer.

Check that the connection of the hardwire converter is made to the electronic board within the electronic flush valve housing.

For further technical assistance, call Delta Commercial Technical Service at 1-800-387-8277.

1. **Start-Up:** When batteries are first inserted, a sequence of red lights that strobe across the sensing lens window will signify that the valve is now in operation mode.
2. **Override Button in Operating Mode:** BLUE light flashes once when Override Button is activated. Should the manual override button stick, the program will continue to operate and will reset automatically if the override button is repaired or it returns to home position.
3. **Battery Level Indicator:** RED light flashes every 3 seconds, indicating approximately 5,000 flushes remain from when RED light first started flashing.
4. **Checking Battery Strength:** In operation mode, it is possible to check the strength of the batteries by holding down the override button until the RED lights begin to flash. The strength of the batteries is proportional to the number of lights that are displayed when the override button is held down. For example, 5 RED lights signify full battery strength; while 1 RED light indicates very weak battery strength (replace batteries when this occurs).

***Note: All original settings will be retained when batteries are changed. If you have made optional adjustments, your settings will be retained when batteries are changed.**

Delta Commercial Faucet Limited Warranty

All parts of the Delta® HDF® and TECK® faucets are warranted to the original consumer purchaser to be free from defects in material, finish and workmanship for a period of five (5) years unless otherwise specifically stated in the catalogue and price book. This warranty is made to the original consumer purchaser and shall be effective from date of purchase as shown on purchaser's receipt.

Delta will, at its option, repair or replace, FREE OF CHARGE, during the warranty period, any part which proves defective in material or workmanship under normal installation, use and water and service conditions. If Delta Faucet concludes that the returned part was manufactured by Delta Faucet and is, in fact, defective, then Delta Faucet will honour the warranty stated herein. Replacement parts can be obtained from your local dealer or distributor listed in the telephone directory or by returning the part along with the purchaser's receipt to our factory, TRANSPORTATION CHARGES PREPAID, at the address listed. THIS WARRANTY IS THE ONLY EXPRESS WARRANTY MADE BY DELTA. ANY CLAIMS MADE UNDER THIS WARRANTY MUST BE MADE DURING THE FIVE YEAR PERIOD REFERRED TO ABOVE. ANY IMPLIED WARRANTIES, INCLUDING THE IMPLIED WARRANTY OF MERCHANTABILITY OF FITNESS FOR A PARTICULAR PURPOSE, ARE LIMITED IN DURATION TO THE DURATION OF THIS WARRANTY. LABOUR CHARGES AND/OR DAMAGE INCURRED IN INSTALLATION, REPAIR OR REPLACEMENT AS WELL AS INCIDENTAL AND CONSEQUENTIAL, SPECIAL, INDIRECT OR PUNITIVE DAMAGES CONNECTED THEREWITH ARE EXCLUDED AND WILL NOT BE PAID BY DELTA FAUCET.

Some states do not allow limitations on how long an implied warranty lasts, or the exclusion or limitation of incidental or consequential damages, so the above limitations or exclusions may not apply to you. This warranty gives you specific legal rights, and you may also have other rights which vary from state to state.

This warranty is for commercial products only from Delta Faucet Company and Delta Faucet Canada (a division of Masco Canada Limited) and is void for any damage to this faucet due to misuse, abuse, neglect, accident, improper installation, any use in violation of instructions furnished by Delta Faucet or any use of replacement parts other than genuine Delta parts.

Garantie Limitée Delta Commercial

Toutes les pièces des robinets de marque Delta® HDF® et TECK® sont garanties contre tout défaut de matériel, de finition et de main-d'oeuvre pour une période de cinq (5) ans, sauf indication contraire stipulée dans le catalogue et la liste des prix. Cette garantie est offerte à l'acheteur original et entre en vigueur à compter de la date d'achat indiquée sur la preuve d'achat.

Delta procédera, à son entière discrétion, à la réparation ou au remplacement, SANS FRAIS, durant la période de garantie, de toute pièce qui présente un défaut de matériel ou de main-d'oeuvre dans des conditions d'installation, d'usure, d'eau et de service normales. Si Delta Faucet détermine que la pièce retournée a été fabriquée par Delta Faucet et qu'en effet, cette pièce défectueuse, Delta Faucet respectera alors la garantie mentionnée ci-dessous. Les pièces de rechange peuvent être obtenues chez votre marchand local ou le distributeur inscrit dans votre annuaire téléphonique, ou en retournant la pièce ainsi que la preuve d'achat à notre usine, FRAIS DE TRANSPORT PRÉPAYÉS, à l'adresse indiquée. CETTE GARANTIE EST LA SEULE GARANTIE EXPRESSE FAITE PAR DELTA.

TOUTE RÉCLAMATION FAITE EN VERTU DE CETTE GARANTIE DOIT ÊTRE PRÉSENTÉE DURANT LA PÉRIODE DE CINQ ANS MENTIONNÉE CI-DESSUS. TOUTE GARANTIE IMPLICITE, Y COMPRIS LA GARANTIE IMPLICITE DE VALEUR COMMERCIALE D'ADÉQUATION POUR UN USAGE PARTICULIER, EST LIMITÉE DANS LE TEMPS À LA DURÉE DE LA PRÉSENTE GARANTIE.

LES FRAIS DE MAIN-D'OEUVRE ET/OU LES DOMMAGES ENCOURUS DURANT L'INSTALLATION, LA RÉPARATION OU LE REMPLACEMENT AINSI QUE LES DOMMAGES ACCIDENTELS ET CONSÉCUTIFS, SPÉCIAUX, INDIRECTS OU PUNITIFS QUI SONT RELIÉS SONT EXCLUS ET NE SERONT PAS PAYÉS PAR DELTA FAUCET.

Certains états ne permettent pas la limitation de la durée de la garantie implicite, ou l'exclusion ou la limitation des dommages accidentels ou consécutifs, et par conséquent, les limitations ou les exclusions stipulées ci-dessus peuvent ne pas s'appliquer dans votre cas. Cette garantie vous accorde certains droits reconnus par la loi et vous pouvez aussi avoir d'autres droits qui varient d'un état à l'autre.

Cette garantie s'applique seulement aux produits commerciaux de Delta Faucet Company et Delta Faucet Canada (une filiale de Masco Canada Limited) et est nulle de plein droit pour tout dommage causé à ce robinet en raison d'une mauvaise utilisation, d'abus, de négligence, d'accident, de mauvaise installation, pour tout usage en contravention des directives fournies par Delta Faucet ou pour tout usage de pièces de rechange autres que des pièces originales Delta.

Garantía Limitada de las Llaves de Agua Comerciales Delta

Todas las piezas de las llaves de agua (grifos) Delta® HDF®, TECK® están garantizadas al comprador consumidor original de estar libres de defectos de material, acabado y fabricación por un periodo de cinco (5) años a menos que sea establecido específicamente de otra manera en el catálogo o libro de precios. Esta garantía se le otorga al comprador consumidor original y será efectiva desde la fecha de compra indicada en el recibo del comprador.

Delta, a su opción, reparará o reemplazará, GRATUITAMENTE, durante el periodo de garantía, cualquier pieza que resulte defectuosa en material o fabricación bajo instalación, uso, agua y condiciones de servicio normales. Si Delta Faucet concluye que la pieza devuelta fue fabricada por Delta Faucet y es, de hecho, defectuosa, entonces Delta Faucet honrará la garantía establecida en este documento.

Las piezas de reemplazo se pueden obtener de su tienda o distribuidor local listado en la guía telefónica o devolviendo la pieza junto con el recibo de compra a nuestra fábrica, CON LOS GASTOS DE ENVÍO PRE-PAGADOS, a la dirección indicada. ESTA GARANTÍA ES LA ÚNICA GARANTÍA EXPRESA HECHA POR DELTA. CUALQUIER RECLAMO HECHO BAJO ESTA GARANTÍA DEBE SER HECHO DURANTE EL PERÍODO DE CINCO AÑOS ARRIBA MENCIONADO. CUALQUIER GARANTÍA IMPLÍCITA, INCLUYENDO LA GARANTÍA IMPLÍCITA DE COMERCIABILIDAD DE EMPLEO PARA UN PROPÓSITO PARTICULAR, TIENE UNA DURACIÓN LIMITADA A LA DURACIÓN DE ESTA GARANTÍA. LOS CARGOS DE MANO DE OBRA Y/O DAÑO INCURRIDO DURANTE LA INSTALACIÓN, REPARACIÓN O REEMPLAZO, COMO TAMBIÉN DAÑOS INCIDENTALES O RESULTANTES, ESPECIALES, INDIRECTOS O PUNITIVOS RELACIONADOS CON LO MENCIONADO, QUEDAN EXCLUIDOS Y NO SERÁN CUBIERTOS POR DELTA FAUCET.

Algunos estados no permiten limitaciones de la duración de una garantía implícita, o la exclusión o limitación de daños incidentales o consecuentes, de manera que las limitaciones o exclusiones arriba mencionadas puedan no aplicarse en su caso. Esta garantía le otorga derechos legales específicos, y usted también puede tener otros derechos que varían de estado a estado.

Esta garantía es solo para productos comerciales de Delta Faucet Company y Delta Faucet Canada (una división de Masco Canada Limited), y queda anulada por cualquier daño ocasionado a esta llave de agua resultante del mal uso, abuso, descuido, accidente, instalación incorrecta, cualquier uso en violación de las instrucciones proporcionadas por Delta Faucet o el uso de cualquier parte de repuesto que no sea una parte genuina de Delta.

Delta Faucet Canada, a division of Masco Canada Limited
350 South Edgeware Road, St. Thomas, Ontario, N5P 4L1
1-800-567-3300 (English) 1-800-265-9245 (French)

Delta Faucet Company
Box 40980, 55 East 111th St., Indianapolis, IN, U.S.A. 46280
(317) 848-1812

For further technical assistance, call Delta Commercial Technical Service at 1-800-387-8277.

Pour obtenir de l'assistance technique, appelez le Service Technique de Delta Commercial au 1-800-387-8277.

Por la asistencia técnica adicional, llame al servicio técnico de Delta Comercial al 1-800-387-8277.