

Electronic Exposed TECK® Flush Valve

TECK®
COMMERCIAL

DELTA

81T231HWA

Exposed Hardwire Operated 3/4" Top Inlet Urinal Fixture

- Polished chrome-plated vandal resistant metal cover with top mounted sensor operated **H₂Optics®** electronics
- Right or left-hand supply installation
- ADA compliant, automatic operation hardwire powered infrared sensor
- Scratch resistant replaceable lens window
- Infrared sensor range adjustment of 203mm - 610mm (8" - 24"), factory set at 16" (±2")
- Hardwire Adaptor 24 VAC to 6.4 VDC converter (supplied)
- Vandal resistant copper tube conduit
- Optional 24 hour automatic flush factory set to OFF
- Set-up sensor range adjustment indicator lights
- 24 VAC input, 6 second arming delay
- Electronic operated non-hold-open **metal** override button with 5 second lockout
- (110 to 24 VAC Transformer not included. See selection below for additional part number.)
- Quiet action, TECK® exposed diaphragm flush valve
- Chloramine resistant diaphragm
- Forged brass diaphragm retainer
- Renewable seat
- Polished chrome-plated body
- **External water conserving flush adjustment**, factory set to 1.9 litre (.50 gal.)
- **1" FIP / 3/4" copper sweat inlet adaptor**, angle check stop with protecting cap
- Adjustable 121mm (4-3/4") plus or minus 11mm (7/16") inlet/valve outlet centers
- Vacuum breaker
- Cover tube, stainless steel wall flange, spud flange, spud nut, and 330mm (13") outlet tube
- **Recommended water supply:**
Minimum flowing pressure – 25 psi (172 kPa)
Minimum flow rate – 8 gpm (30 L/min)

APPROVALS:

- IAPMO listed to ASSE 1037/ ASME A112.1037/CSA B125.37
-  Indicates compliance to ICC/ANSI A117.1

(Contact Delta Representative for State and/or Local Approvals.)

Patented



Engineer/Architect Approval

Model Specified:

Approval:

Date:

81T231HWA



81T231HWA-19

Same as 81T231HWA, **Not Field Adjustable**



81T231HWA-05

Same as 81T231HWA, but set to 0.5 litre (0.125 gal.), **Not Field Adjustable**



AVAILABLE OPTIONS FOR FIELD CONVERSION

061047A

Hardwire with Battery Backup

See **DSP-BB** for detailed specification.



TRANSFORMERS

060704A	110 to 24 VAC Class 2 20 VA (for up to 5 Electronic Valves)
060771A	110 to 24 VAC Class 2 40 VA (for up to 10 Electronic Valves)

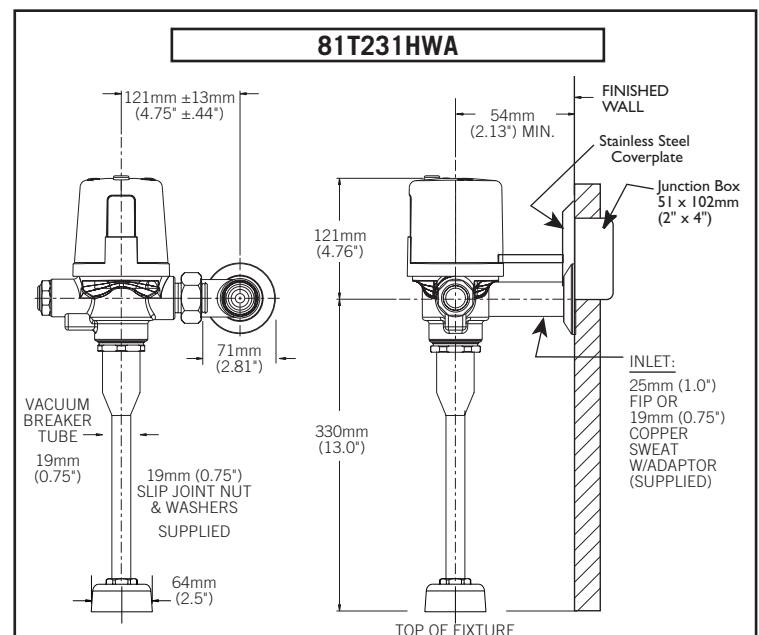

Note: For high and low pressure applications, please see page FEA-81T High Water Pressure note for more details.

Verify flow requirements with bowl manufacturer.

Note: Measurements may vary ± 6mm (0.25")

Refer to www.specselect.com for individual models.

Note: Use this page as a product submittal sheet.