

590TP Series – Electronic Faucet

With Surface Mount Control Box and Single Inlet Supply

TECK[®]
COMMERCIAL



Specification: (example)

- Supplied as complete product
- **Proximity[®] Sensing Technology**
- Chrome plated **CAST** Hi-Rise spout
- **Battery** (4 'C' cell) or **Hardwire** (24 VAC) deckmount electronic handwash system
- Adjustable sensing range and timeout
- Forged brass solenoid valve
- Surface mount housing
- Mixing valve required (order separately)
- Serviceable filter screen upstream of the valve

and... with... (specify battery or hardwire)
with... (add spout variation required)
with... (add outlet required)
with... (transformer required for hardwire models – specify separately – See Back Page)

590TP0130



Engineer/Architect Approval

Model Specified:

Approval:

Date:

DESCRIPTION	PRODUCT NO.			
Hardwire	590TP0			0
Battery Operated	590TP1			0
Hardwire with Battery Backup	590TP0			0
				-BB



SPOUT VARIATION	OUTLET	CONTROL BOX
<p>0 <input type="checkbox"/></p>	<p>0 <input type="checkbox"/></p>	<p>0 Surface Mount Housing* SEE Specification Drawing #29 <input checked="" type="checkbox"/></p>
<p>1 Single Hole Deckmount Hi-Rise Spout <input type="checkbox"/></p>	<p>1 <input type="checkbox"/></p>	<p>1 <input type="checkbox"/></p>
<p>2 Deckmount Hi-Rise Spout with 4" Forged Coverplate <input type="checkbox"/></p>	<p>2 Vandal Resistant 1.5 gpm (5.7 L/min.) Laminar w/Agion[®] Antimicrobial <input type="checkbox"/></p>	<p>2 <input type="checkbox"/></p>
<p>3 <input type="checkbox"/></p>	<p>3 Vandal Resistant 1.5 gpm (5.7 L/min.) Flow Control Aerator <input type="checkbox"/></p>	<p>3 <input type="checkbox"/></p>
<p>4 <input type="checkbox"/></p>	<p>4 <input type="checkbox"/></p>	<p>4 <input type="checkbox"/></p>
<p>5 <input type="checkbox"/></p>	<p>5 Vandal Resistant 0.5 gpm (1.9 L/min.) Laminar Outlet <input type="checkbox"/></p>	<p>5 <input type="checkbox"/></p>
<p>6 <input type="checkbox"/></p>	<p>6 Vandal Resistant 1.0 gpm (3.8 L/min.) Laminar Outlet <input type="checkbox"/></p>	<p>6 <input type="checkbox"/></p>
<p>7 <input type="checkbox"/></p>	<p>7 <input type="checkbox"/></p>	<p>7 <input type="checkbox"/></p>
<p>8 Deckmount Hi-Rise Spout with 8" Forged Coverplate <input type="checkbox"/></p>	<p>8 <input type="checkbox"/></p>	<p>8 <input type="checkbox"/></p>
<p>9 <input type="checkbox"/></p>	<p>9 Vandal Resistant 0.35 gpm (1.32 L/min.) Non-Aerating Spray Outlet <input type="checkbox"/></p>	<p>9 <input type="checkbox"/></p>

*Mixing valve (order separately). Refer to www.specselect.com for individual models.

Note: Use this page front and back, with specification drawing page referenced above, as product submittal sheets. Flow Rates are at 60 PSI.

Delta reserves the right (1) to make changes in specifications and materials, and (2) to change or discontinue models, both without notice or obligation. Dimensions are for reference only. See current full-line price book or www.specselect.com for finish options and product availability.

DSP-590TP Rev. F



TECK[®]
COMMERCIAL

590TP Series – Electronic Faucet

With Surface Mount Control Box and Single Inlet Supply

Approvals:

- CSA certified
- Complies to ASME A112.18.1/CSA B125.1
- Indicates compliance to ICC/ANSI A117.1
- Outlet options 2, 3 and 6 are EPA WaterSense listed
- Verified compliant with 0.25% weighted average Pb content regulations

(Contact Delta Representative for State and/or Local Approvals.)

Patented

FLOW RATE vs PRESSURE

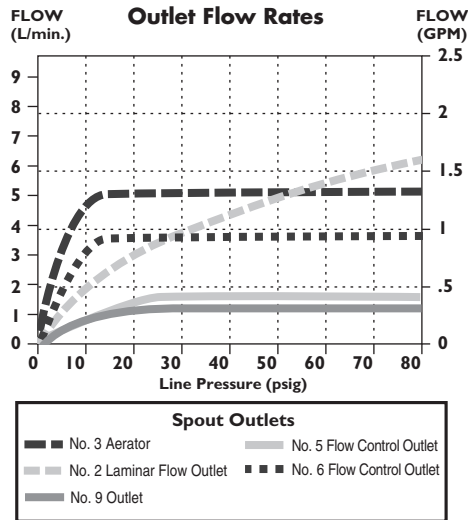

OPERATION:

- Hands free (touchless) operation.
- No visible sensor, the spout is the sensor.
- Water flows when sensing is activated.
- Water flow stops upon de-activation of sensing.
- Adjustable sensing distance factory set to 76 mm (3").
- Low battery audible beep (for battery models only) will activate after faucet shuts off when approximately 1500 cycles remain.
- Adjustable auto shut off feature. Factory set to 45 seconds.
- Metering mode with selectable flow times of 7 seconds to 4 minutes, factory set off.
- Periodic Rinse feature, time adjustable in 6 hour increments up to 2 days. Selectable rinsing lengths from 10 to 180 seconds. Factory set off.

NOTE 1: For optimum performance of this product, we recommend a system pressure between 20 and 80 PSI static. This product will operate up to a maximum of 125 PSI static per ANSI and CSA requirements. However, we do not recommend pressures above 80 PSI. Thermal expansion or leaking pressure reducing valves may require use of expansion tanks or relief valves to ensure your system never exceeds its maximum intended pressure setting.

NOTE 2: Designed for routine 180°F (82°C) disinfection cycles up to 10 minutes.

NOTE 3: Hardwire Proximity models not for use on enamel covered metal sinks.

Note: Measurements may vary ± 6mm (0.25")

Refer to www.specselect.com for individual models. Product supplied as shown by solid lines. All items shown by dotted lines supplied by others.

SPOUT #1

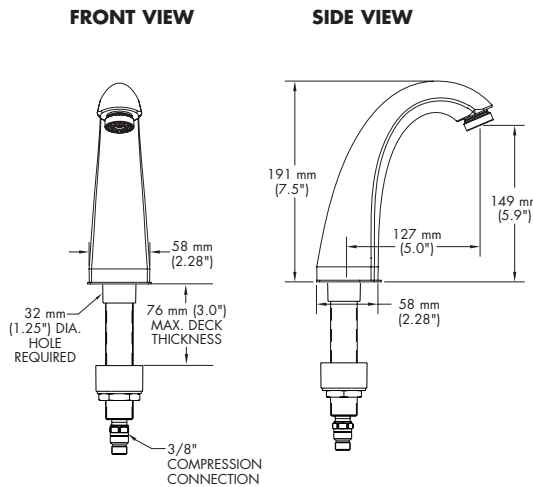

590TP0150 TYPICAL INSTALLATION

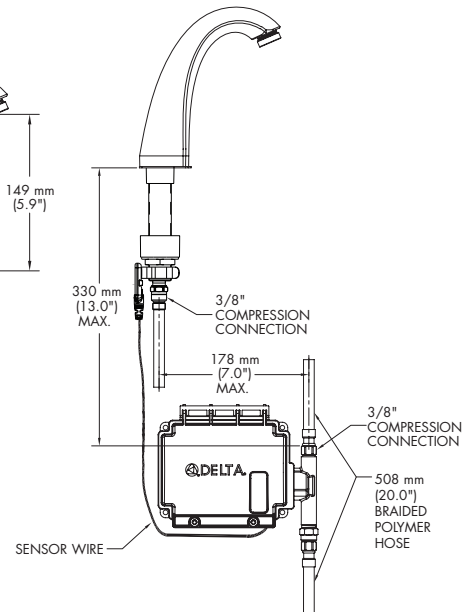

SPOUT #2 (4" COVERPLATE) & SPOUT #8 (8" COVERPLATE)

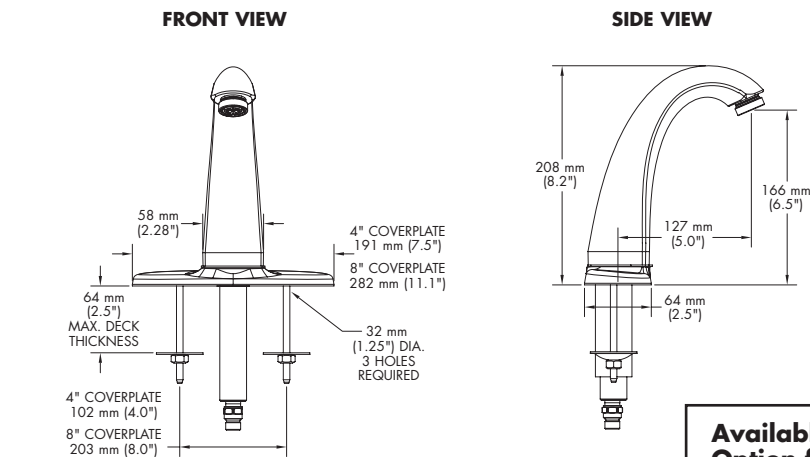

HARDWIRE WITH BATTERY BACKUP

Add suffix "-BB" to Product Number. See DSP-BB for detailed specification.

Available Option for Field Conversion

060651A
3 Position Switch
See DSP-ELACC for detailed specification.

590TP ELECTRONIC FAUCET OPTIONAL ACCESSORIES:

✓	TRANSFORMERS:
✓	060704A 110 to 24VAC Class II 20VA (Up to 5 Electronic Valves)
	060771A 110 to 24VAC Class II 40VA (Up to 10 Electronic Valves)
	060772A 110 to 24VAC Class II 100VA (Up to 25 Electronic Valves)
✓	CORDS:
	061256A 36" Cable Extension

SURFACE MOUNT CONTROL BOX #0

590TP SERIES

✓	PRODUCT NO.			VALVE TYPE	COVER
	590TP	0	0	Deckmount Handwash Hardwire	Surface Mounted, Vandal Proof Control Housing
	590TP	1	0	Deckmount Handwash Battery	Surface Mounted, Vandal Proof Control Housing

VANDAL PROOF SURFACE MOUNT CONTROL HOUSING

590TP SERIES

Battery Operated – Box shown.

Hardwire Version comes complete with Watertight Connector and Hardwire Converter 24VAC to 6VDC.

Hardwire with Battery Backup (-BB) comes complete with Watertight Connector, Hardwire Converter 24VAC to 6VDC and 9V battery. **See DSP-BB for detailed specification).**

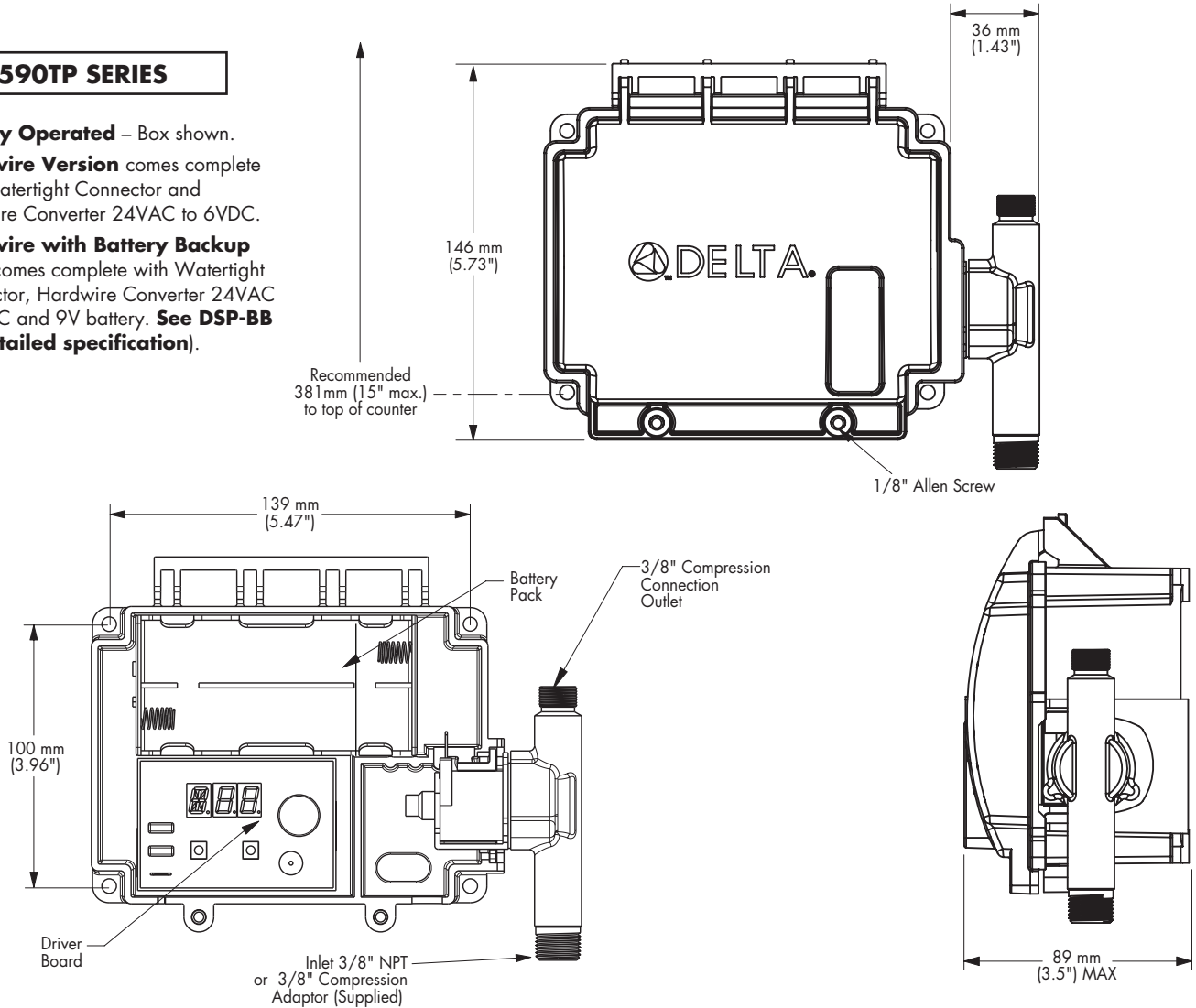

BRAIDED HOSE

Note: Braided polymer hose connections supplied between Solenoid Valve and Spout as well as for Solenoid Valve Inlet

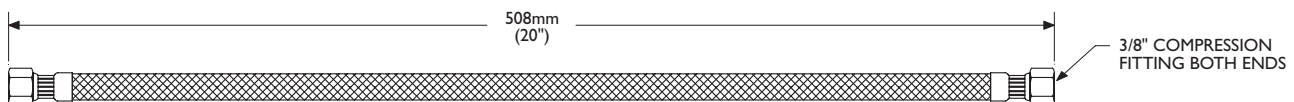

Note: Measurements may vary ± 6 mm (0.25")