

# Electronic Exposed TECK® Flush Valves

**TECK**  
COMMERCIAL

**DELTA**

## 81T231BTA-MMO

### Exposed Battery Operated 3/4" Top Inlet Urinal Fixture

- Polished chrome plated vandal resistant metal cover with top mounted sensor operated **H<sub>2</sub>Oprics**® electronics
- True mechanical manual override button**
- Right or left-hand supply installation
- ADA compliant, automatic operation battery powered infrared sensor
- Scratch resistant replaceable lens window
- Four (4) size AA alkaline batteries factory installed with valve in sleep mode for easy installation
- Hinged battery housing for easy maintenance
- Low battery flashing light (5,000 flushes remaining) with battery strength indicator
- Infrared sensor range adjustment of 203 mm - 610 mm (8" - 24"), factory set at 16" (±2")
- Optional 24 hour automatic flush factory set to OFF
- Set-up sensor range adjustment indicator lights
- 6 VDC input, 6 second arming delay
- Electronic operated non-hold-open **metal** override button with 5 second lockout
- Quiet action, TECK® exposed diaphragm flush valve
- Chloramine resistant diaphragm
- Forged brass diaphragm retainer
- Renewable seat
- Polished chrome-plated body
- External water conserving flush adjustment**, factory set to 1.9 Lpf (0.50 gpf)
- 1" FIP / 3/4" copper sweat inlet adaptor**, angle check stop with protecting cap
- Adjustable 121 mm (4-3/4") plus or minus 11 mm (7/16") inlet/valve outlet centers
- Vacuum breaker
- Cover tube, wall flange, spud flange, spud nut and 330 mm (13") outlet tube
- Recommended water supply:**  
Minimum flowing pressure – 25 psi (172 kPa)  
Minimum flow rate – 8 gpm (30 L/min)

## 81T231BTA-05-MMO

Same as 81T231BTA-MMO, but set to 0.5 Lpf (0.125 gpf),  
**Not Field Adjustable**



## APPROVALS:

- IAPMO listed to ASSE 1037/  
ASME A112.1037/CSA B125.37
- Indicates compliance to  
ICC/ANSI A117.1

(Contact Delta Representative for State and/or  
Local Approvals.)

Patented



## Engineer/Architect Approval

Model Specified:

Approval:

Date:

## 81T231BTA-MMO

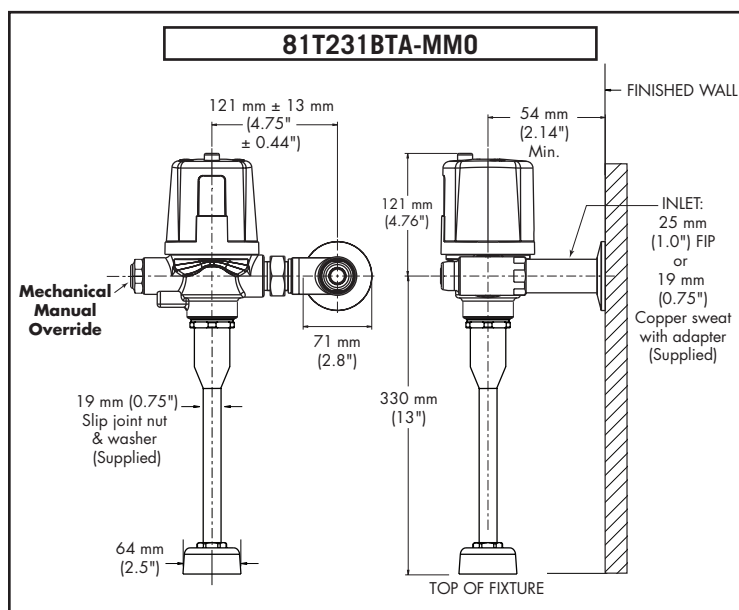

Note: For high and low pressure applications, please see page  
FEA-81T High Water Pressure note for more details.

Verify flow requirements with bowl manufacturer.

Note: Measurements may vary ± 6mm (0.25")

Refer to [www.specselect.com](http://www.specselect.com) for individual models.

Note: Use this page as a product submittal sheet.