

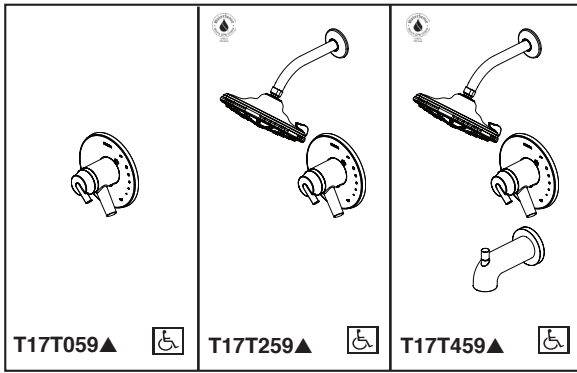

see what Delta can do™

TUB AND SHOWER FAUCET TRIM

- Trinsic® Series
- Valve Only (T17T059)
- Shower Only (T17T259)
- Tub/Shower (T17T459)



Submitted Model No.: _____
 Specific Features: _____

FEATURES:

- TempAssure® 17T thermostatic valve cartridge

STANDARD SPECIFICATIONS:

- Thermostatic wax element maintains the outlet temperature to $\pm 3.6^{\circ}\text{F}$
- Back-to-back installation capability
- Lever volume control handle; temperature adjustment dial
- Red/blue indicator markings
- Field adjustable to limit handle rotation into hot water zone
- All parts replaceable from the front of the valve
- Available extension kit (RP75136) adds up to 1 3/8" installation depth
- Three setting H₂Okinetic Technology® showerhead; 1.75 gpm @ 80 psi, 6.6 L/Min @ 550 kPa
- For use with MultiChoice® Universal rough valve body (R10000 Series) ordered separately

WARRANTY

- Lifetime limited warranty on parts (other than electronic parts and batteries) and finishes; or, for commercial users, for 5 years from date of purchase.
- 5 year limited warranty on electronic parts (other than batteries); or, for commercial users, for 1 year from the date of purchase. No warranty is provided on batteries.

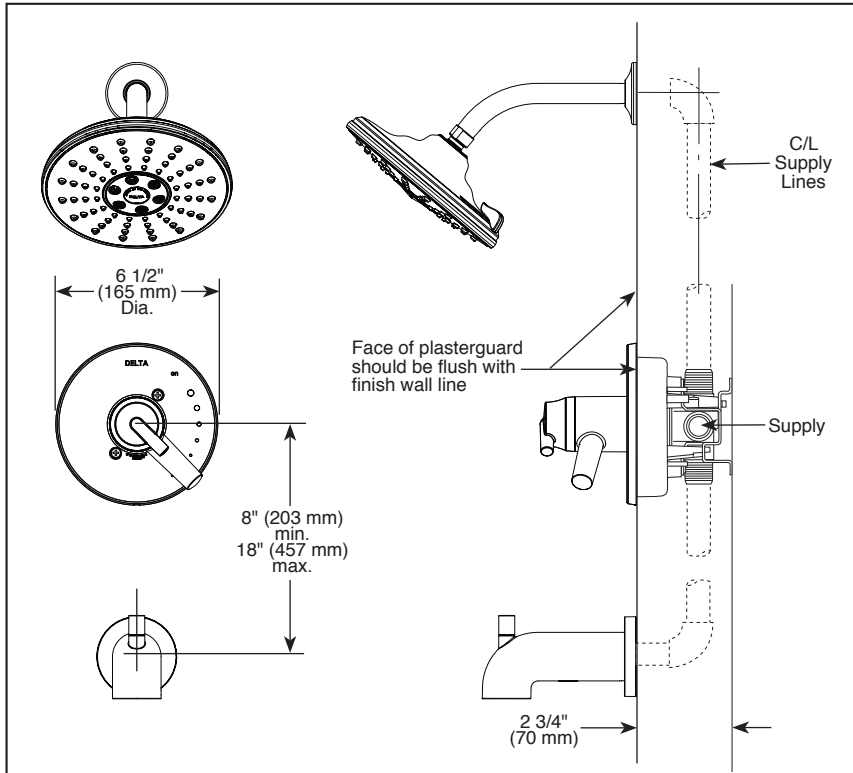

▲ Designate Proper Finish Suffix

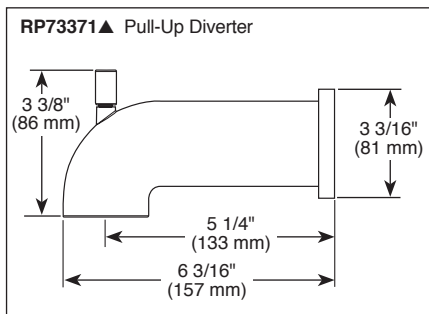
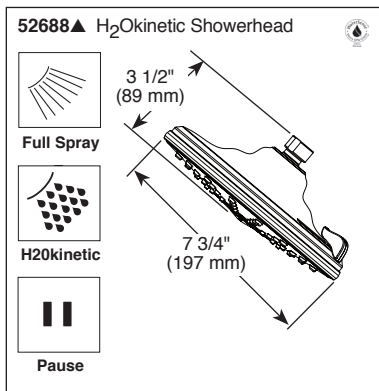

COMPLIES WITH:

- ASME A112.18.1 / CSA B125.1
- ASSE 1016
- ☑ Indicates compliance to ICC/ANSI A117.1 - Valve control only
- EPA WaterSense®

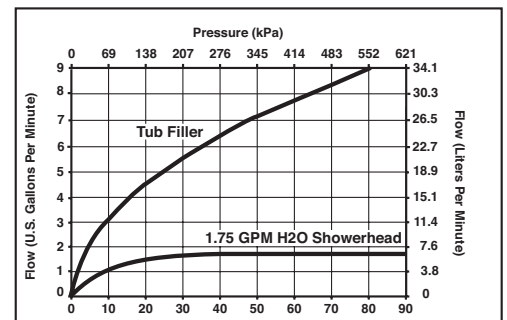

Delta reserves the right (1) to make changes in specifications and materials, and (2) to change or discontinue models, both without notice or obligation. Dimensions are for reference only. See current full-line price book or www.deltafaucet.com for finish options and product availability.