

WRAPPER FOR FREE STANDING ICEMAKER INSTALLATION INSTRUCTIONS

Before you begin, read these instructions completely and carefully.

Getting Started

Remove packaging and retain until installation is complete.

CAUTION:

The surface on which the grill cart and Icemaker are located must be flat and level. Icemaker should be installed near water and drain supply. All plumbing must be out of the way of any foot traffic.

Note: Wrapper must be installed on the Icemaker and attached to the grill cart before the grill head is installed on the cart.

WARNING!

Some parts have sharp edges; care must be taken when handling the various components to avoid injury. Please read safety information provided in these instructions before beginning assembly. Wear gloves when handling.

Contents

Part Description	Qty
Hardware Kit Includes:	1
Protective Grommet, 2.50 Diameter	1
Protective Grommet, 1.25 Diameter	1
Machine Screw 10-24 X 1-1/8	8
Sheet Metal Screw 10-24 X 1/2	2
Hex Bolt 1/4-20 X 1/2	2
Nut, Hex 1/4-20	2
Nut, Tinnerman U-nut #10-24 MS	4
Machine Screw 10-24 X 3/8	4
7" Cable Tie	1

Tools Required

Phillips Screwdriver
5/16 Socket/Nutdriver and 5/16 Wrench
Safety Glasses
Work Gloves

Installation Instructions

Assembly instructions for Freestanding application:

Note: Installation of optional drain pump (sold separately - model # RF15I-P) must be done before installation of wrapper.

1. Loosen (2) screws on front bottom grill cover (Fig. 01) approx. 1/8". (No need to remove screws.)

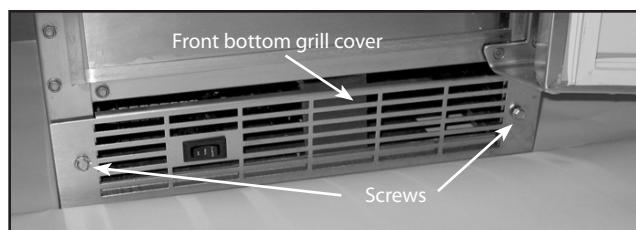

Fig. 01

- Remove (4) screws on back panel of Icemaker as shown (Fig. 02). (Retain screws for re-use.)



Fig. 02

- Install 2 Tinnerman U-Nuts on Icemaker Adapter (Fig. 03) and attach to upper area of Icemaker as shown (Fig. 04). Repeat for the bottom location (Fig. 05). Tighten all screws at this point. See Fig. 06 for final placement.

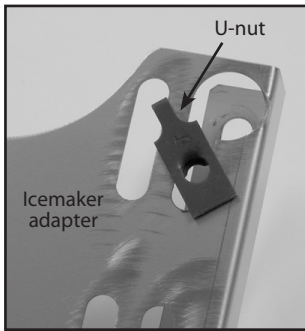

Fig. 03

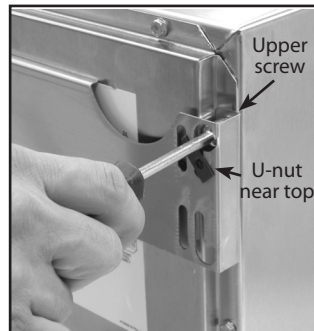

Fig. 04

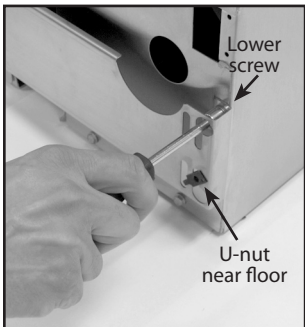

Fig. 05

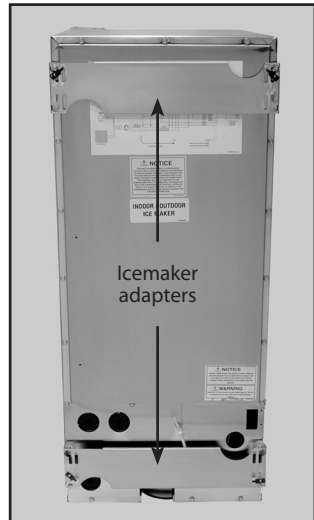

Fig. 06

- Place the left side panel on the unit by sliding the bottom front flange behind the front grill plate (Fig. 07). Then lift the rear of the panel so the U-nut holes are visible in the slotted holes of the upper and lower rear flanges of the panel. Install machine screws (10-24 X 3/8) into U-nuts as shown (Fig. 08 and 09). Do not tighten at this point.

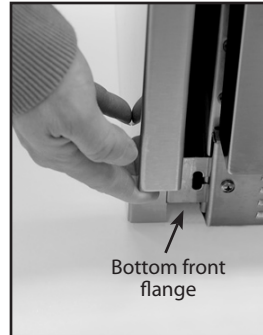

Fig. 07



Fig. 08

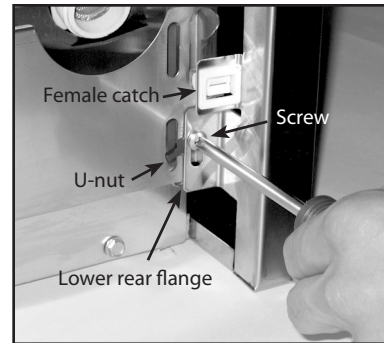

Fig. 09

- Repeat Step 4 for the other side panel.
- Place both top risers on top of unit as shown in Fig. 10.

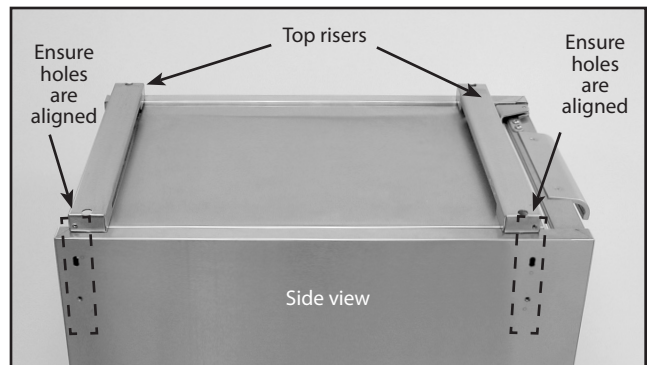

Fig. 10

- Using screws provided (10-24 X 1-1/8), attach riser to the side panels. Take note of the alignment of the holes on the riser and side panel (Fig. 11).



Fig. 11

- Adjust the side panels to be level with the top of the Icemaker, then tighten all flange screws.
- The 4 male catch clips are preinstalled in the back panel. See your Icemaker Use & Care Manual for instructions on connecting to your potable water supply and drain. Route the supply hose thru the large opening in the back panel and connect to the inlet on the back of the Icemaker. If you have installed the optional drain pump (sold separately - model # RF15I-P), feed the drain line thru this same large opening. Feed the power cord thru the smaller opening and install protective grommets on both openings (Fig. 12).

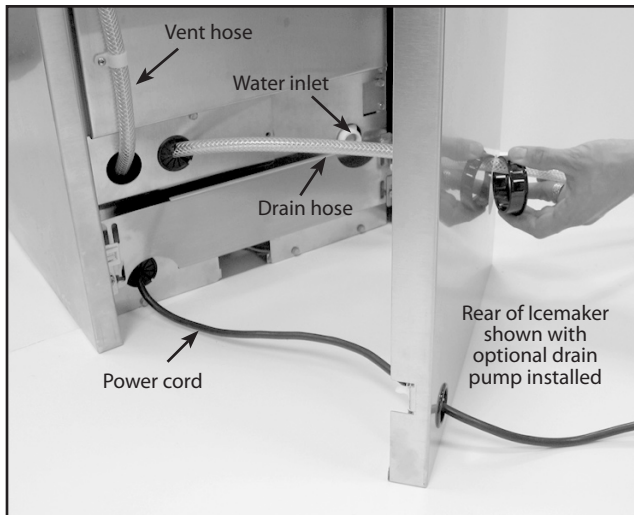

Fig. 12

- Once you have tested the unit and verified there are no leaks, align the rear panel male clips to the preinstalled female clips of the side panels, push at the outer corners to engage clips. See Fig. 13 for final assembly. Do not bundle-up excess hose & cord behind the panel.



Fig. 13

Solid Surface Installation – Required Accessory (sold separately):

■ Solid Surface for Icemaker (WRT15I)

- Locate holes on the solid surface and place onto the Icemaker so the holes align on the sides. Check for proper fit and alignment. Insert screws (10-24 X 1-1/8) to anchor solid surface to risers. See Fig. 14 for final assembly.



Fig. 14

- Final check to see that all spacing and gaps are even and level.

Assembly Instructions for Modular application (linked to a CAD cart):

Note: Installation of optional drain pump (sold separately - model # RF15I-P) must be done before installation of wrapper.

1. Remove (2) screws on front bottom grill cover from the Icemaker and set them aside (Fig. 01).
2. Remove (4) screws on back panel of Icemaker as shown (Fig. 02). (Retain screws for re-use.)
3. Install 2 Tinnerman U-Nuts on Icemaker Adapter (Fig. 03) and attach to upper area of Icemaker as shown (Fig. 04 and 05). Repeat for the bottom location. Tighten all screws at this point.
4. With the grill head out of the cart, place the corresponding wrapper side panel against cart side. Align the holes at the top front and rear side corners and install hex bolts (1/4-20 X 1/2 HEX BLT) and locking nuts (1/4-20 HEX NUT) provided with hardware kit, using the second hole from the top on the cart panel and top hole on the wrapper panel (Fig. 15). Do not tighten at this point.

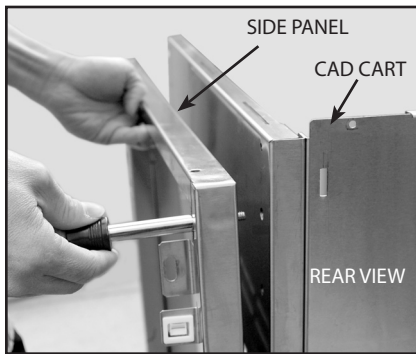

Fig. 15

5. Before connecting the two units, make sure that all of the height requirements are matched:
 - a. The Icemaker leveling legs can be adjusted to match the cart assembly or your counter top. Check the level on both units. The bottom front corners will match and the front faces will be flush (Fig. 16).

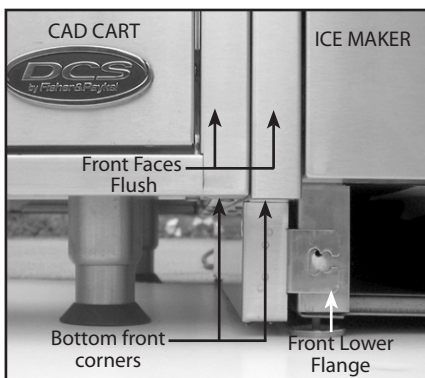

Fig. 16

- b. When installing multiple units as a permanent installation (such as an island) it is recommended to remove the cart casters and install leveling legs (sold separately - model # CAD-LVL).
3. Align the bottom front flange with the Icemaker (Fig. 06). Slide the units together so the U-nut holes are visible in the slotted holes of the upper and lower rear flanges of the side panel. Install machine screws (10-24 X 3/8) into U-nuts as shown (Fig. 07 and 08). Do not tighten at this point. Take care not to damage flanges on the female clips.
 4. Level the legs on the Icemaker as described in 5a. Reinstall bottom front grill cover and screws. Leave screws loose about 1/8 of an inch.

Note: If connecting Icemaker between carts, repeat steps (4-6) for opposite side of Icemaker, then proceed to step 9.

5. Place the other side panel on the unit by aligning bottom front flange with the Icemaker (Fig. 06). Lift the rear of the side so the U-nut holes are visible in the slotted holes of the upper and lower rear flanges of the side panel. Install machine screws (10-24 X 3/8) into U-nuts as shown (Fig. 07 and 08). Do not tighten at this point. Take care not to damage flanges on the female clips.
6. Place both top risers on top of unit as shown in (Fig. 09).
7. Using the machine screws provided (10-24 X 1-1/8) attach risers to side panels. Take note of alignment of the holes on the riser and side panels (Fig. 10).
8. Make a final adjustment to the Icemaker leveling legs so the side panels are level with the top unit, and then tighten all screws, front and rear.
9. The 4 male catch clips are preinstalled in the back panel. See your Icemaker Use & Care Manual for instructions on connecting to your potable water supply and drain. Route the supply hose thru the large opening in the back panel and connect to the inlet on the back of the Icemaker. If you have installed the optional drain pump (sold separately - model # RF15I-P), feed the drain line thru this same large opening. Feed the power cord thru the smaller opening and install protective grommets on all openings (Fig. 11).
10. Once you have tested the unit and verified there are no leaks, align the rear panel male clips to the preinstalled female clips of the side panels, push at the outer corners to engage clips. See Fig. 14 for final assembly. Do not bundle-up excess hose & cord behind the panel.
11. See Solid Surface Installation (page 3).
12. The grill head(s) can now be installed in the grill cart, refer to instructions in Grill or Cart Manual.

For optional type and colors of the Solid Surface, contact your local manufacturer and provide drawing in Fig. 17.

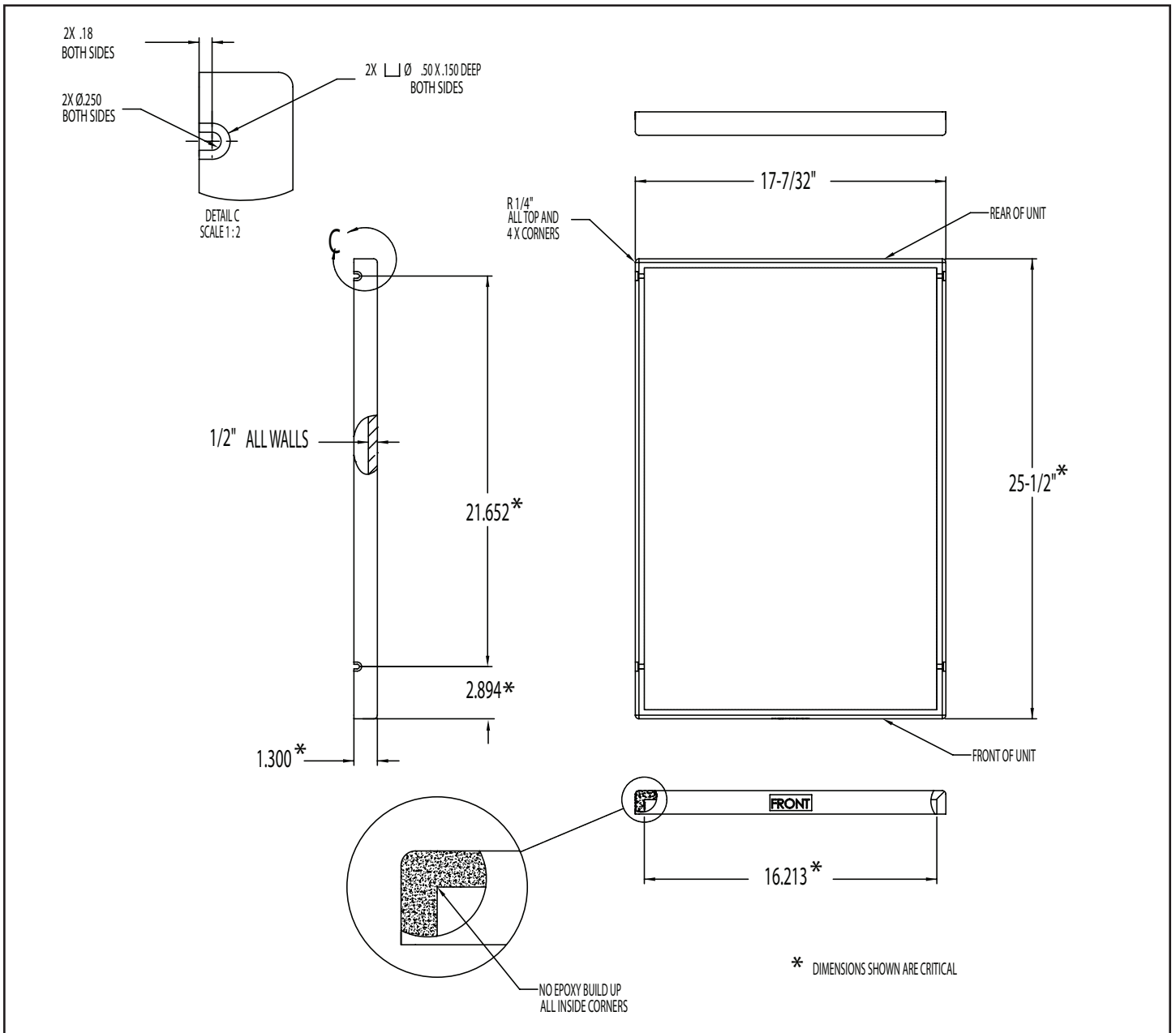

Fig. 17

NOTES

NOTES



Quality provided by Fisher & Paykel Appliances Inc.

Fisher & Paykel Appliances, Inc.
5900 Skylab Road, Huntington Beach, CA 92647
Customer Care: 888.281.5698 • Fax: 714.372.7003
www.dcsappliances.com

P/N 242828 RA 06/08