



# DLHA502

Retractable arms mounted on lexan plate for surface mounting. Uses 50W MR16 bulb (EXN-CG) included. Max. extension 31" (79cm). C/w 12' (366cm) cord, in-line switch and grounded plug-in transformer.

## Bulb installation

Use only EXN-CG type 50W max., c/w covered glass.  
Screws "D" holding bulb pins must be loosened to remove bulb & then tightened.  
Do not remove or replace bulb without loosening these screws.

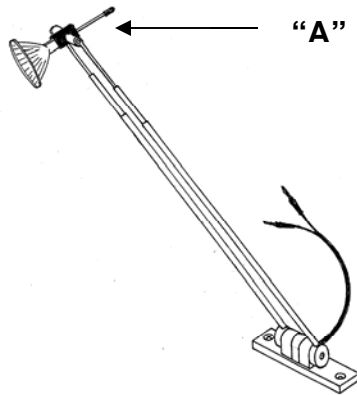

## WARNING

**Screw "A" must always be snug.**  
Failure to do so will cause arcing and burn out the socket.

**Do not cross antennas!**  
This will cause the transformer to burn out!

**Failure to follow these instructions will void warranty**

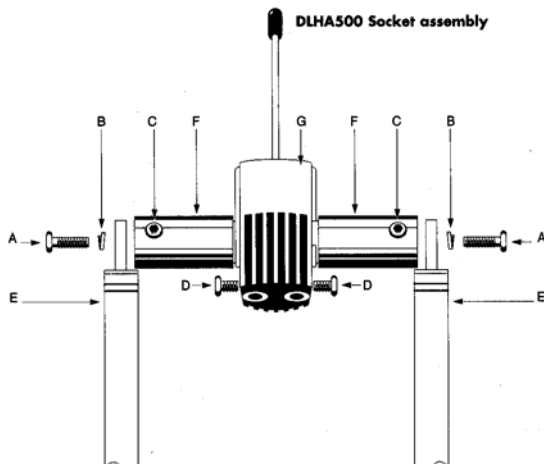

To install or remove screw "A", the set screw "C" must be loosened (allen key not provided). Screw "A" will not loosen or tighten without first loosening set screw "C". If you try to tighten screw "A" without loosening set screw "C" you will break arm "F" from base of socket "G". Breakage of arm "F" is not covered under warranty.

Screw "A" must be tightened firmly on both sides. Once this is done, tighten set screw "C". This locks-down screw "A" and will not allow it to loosen easily. Be sure lock washer "B" is in the proper position before tightening screw "A". If the socket (when bulb is installed) will not hold the position it is rotated to, screws "A" are not tight enough.

1401 Courtnepark Drive East, Mississauga, Ontario, Canada, L5T 2E4

Tel. (905) 564-1262 Fax. (905) 564-1299

E-Mail: [dainolite@dainolite.ca](mailto:dainolite@dainolite.ca) Web: [dainolite.ca](http://dainolite.ca)

May 30, 2007