



# 30-INCH FREEZER COLUMN, PANEL-READY

DRZ30980RAP | DRZ30980LAP



## PRODUCT FEATURES

- Full height door with true flush cabinet integration without exposed venting grille
- SteelCool™ Stainless Steel Interior Illuminated by 3DLighting™
- Push-To-Open™ Door Assist opens the door upon a slight push for a luxuriously convenient experience
- Dual icemaker with Standard and Cocktail Ice™
- Best-in class food preservation with dedicated evaporator/compressor and Precise Cooling Technology

## TEMPERATURE RANGES

|                        |                             |
|------------------------|-----------------------------|
| FREEZER                | 5°F (-15°C) TO -8°F (-23°C) |
| FREEZER - POWER FREEZE | -8°F (-23°C)                |

## DIMENSIONS & WEIGHT

|  |                         |
|--|-------------------------|
| APPLIANCE DIMENSIONS (W X H X D) (IN.) | 29 3/4" X 83 3/8" X 25" |
| REQUIRED CUTOUT SIZE (W X H X D) (IN.) | 30" X 84" X 25"         |
| NET WEIGHT (LBS)                       | 483                     |

## GENERAL PROPERTIES

|  |  |
|--|--|
| PANEL READY                                      | YES  |
| DOOR SWING                                       | LAP-LEFT, RAP-RIGHT                          |
| PUSH-TO-OPEN™ DOOR ASSIST                        | YES  |
| ICEMAKER   | DUAL ICEMAKER FOR STANDARD AND COCKTAIL ICE™ |
| LIGHTING   | 3DLIGHTING™                                  |
| INTERIOR MATERIAL                                | STEELCOOL™ STAINLESS STEEL INTERIOR          |
| FULL WIDTH SHELVES                               | 3 EA   |
| SHELF MATERIAL                                   | TEMPERED, METAL TRIM, SPILL-PROOF            |
| FULL EXTENSION DRAWERS AT 90° DOOR OPENING ANGLE | YES  |
| HIDDEN COMPARTMENT WITH FLIP-UP COVER            | 1 EA   |
| FREEZER DRAWER                                   | 2 EA   |
| DOOR BINS  | 4 EA   |
| DOOR OPEN ALARM                                  | YES  |
| SPECIAL MODES                                    | SABBATH MODE                                 |

## CAPACITY

|   |             |
|---|-------------|
| TOTAL UNIT GROSS CAPACITY (CU.FT.) - AHAM | 176 CU. FT. |
| REFRIGERATOR GROSS CAPACITY (CU.FT.)      | 176 CU. FT. |

## PERFORMANCE

|  |            |
|--|------------|
| DEDICATED EVAPORATOR & COMPRESSOR SYSTEM | YES        |
| POWER FREEZE                             | YES        |
| DEFROST PROCESS                          | FROST-FREE |
| PRECISE COOLING                          | YES        |

## EFFICIENCY

|                           |              |
|---------------------------|--------------|
| ENERGY STAR QUALIFIED     | YES          |
| ANNUAL ENERGY CONSUMPTION | 550 KWH/YEAR |

## TECHNICAL DETAILS

|                         |                |
|-------------------------|----------------|
| CURRENT (A)             | 15             |
| VOLTS (V)               | 115            |
| FREQUENCY (HZ)          | 60             |
| POWER CORD LENGTH (IN.) | 78 3/4"        |
| PLUG TYPE               | 120 V, 3 PRONG |

## WARRANTY

|  |   |
|--|---|
| LIMITED, ENTIRE APPLIANCE, PARTS AND LABOR ON ANY PART OF THE REFRIGERATOR | 2 YEAR                                    |
| LIMITED WARRANTY FOR SEALED REFRIGERATION SYSTEM; PARTS AND LABOR          | 3 <sup>RD</sup> TO 6 <sup>TH</sup> YEAR   |
| LIMITED WARRANTY FOR SEALED REFRIGERATION SYSTEM; PARTS ONLY               | 7 <sup>TH</sup> TO 12 <sup>TH</sup> YEAR  |
| LIMITED WARRANTY FOR COMPRESSOR; PARTS ONLY                                | 13 <sup>TH</sup> TO 15 <sup>TH</sup> YEAR |



# 30-INCH FREEZER COLUMN, PANEL-READY

## APPLIANCE DIMENSIONS

|                            |                     |
|----------------------------|---------------------|
| A (WIDTH)                  | 29 3/4" (756 MM)    |
| B (WITH PANEL)             | 25" (635 MM)        |
| B1 (WITHOUT PANEL)         | 23 13/16" (605MM)   |
| C (HEIGHT)                 | 83 3/8" (2118MM)    |
| D                          | 29 5/8" (752 MM)    |
| D1 (WITH PANEL)            | 30 7/8" (784 MM)    |
| D2 (WITH MODERNIST HANDLE) | 32 3/4" (832 MM)    |
| D3 (WITH PRO HANDLE)       | 33 3/8" (848 MM)    |
| E                          | 56 11/16" (1440 MM) |
| F                          | 16 9/16" (421 MM)   |
| G                          | 55 5/16" (1404 MM)  |

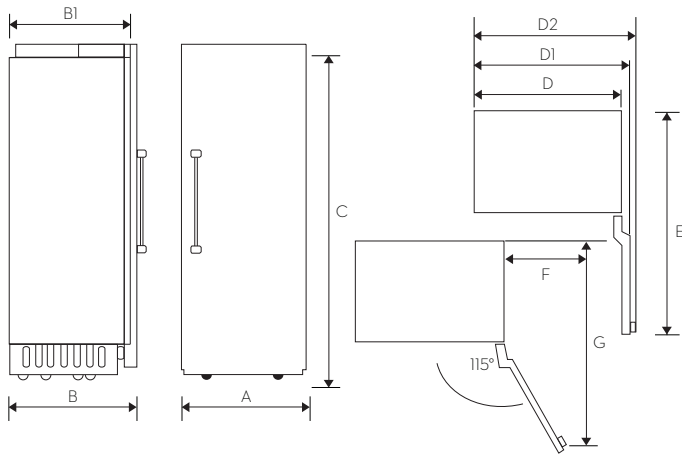

## INSTALLATION CUTOUT DIMENSIONS

|            |               |
|------------|---------------|
| A (WIDTH)  | 30" (762MM)   |
| B (DEPTH)  | 25" (635MM)   |
| C (HEIGHT) | 84" (2,134MM) |
| D          | 20" (508MM)   |
| E          | 80" (2,032MM) |

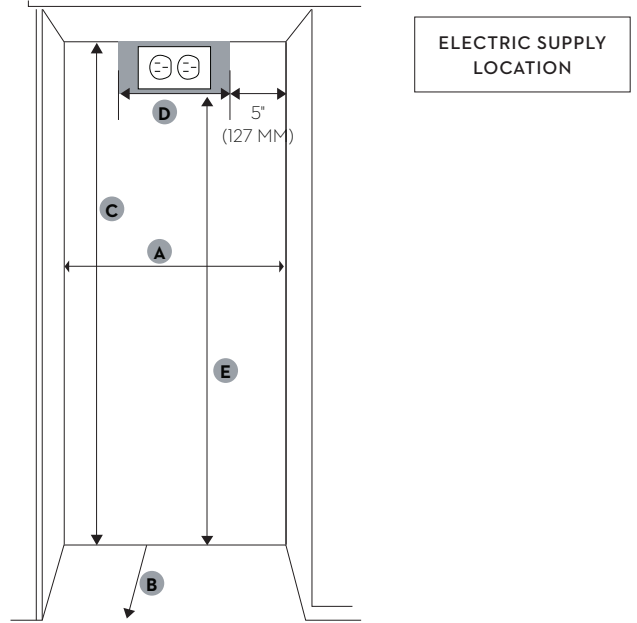

## CUSTOM PANEL DIMENSIONS

|              |                   |
|--------------|-------------------|
| A-1 (WIDTH)  | 29 3/4" (756MM)   |
| A-2 (HEIGHT) | 79 7/8" (2,029MM) |
| A-3 (DEPTH)  | 3/4" (19MM)       |
| MAX WEIGHT   | 88.0 LBS. (40KG)  |

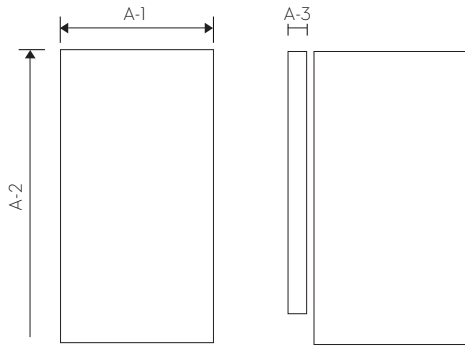

## WATER SUPPLY CONNECTION REQUIREMENTS

|   |             |
|---|-------------|
| A | 6" (154 MM) |
|---|-------------|

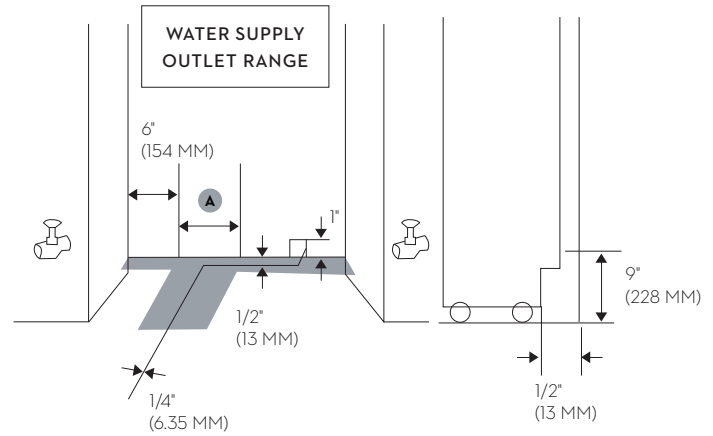

## ACCESSORIES

|   |   |
|---|---|
| MODERNIST GRAPHITE STAINLESS STEEL - 30" PANEL KIT  | RAC30AMRHMS (RIGHT HINGE), RAC30AMLHMS (LEFT HINGE) |
| MODERNIST SILVER STAINLESS STEEL - 30" PANEL KIT    | RAC30AMRHSR (RIGHT HINGE), RAC30AMLHSR (LEFT HINGE) |
| HERITAGE PRO SILVER STAINLESS STEEL - 30" PANEL KIT | RAC30AHRHSR (RIGHT HINGE), RAC30AHLHSR (LEFT HINGE) |
| MODERNIST GRAPHITE STAINLESS STEEL - 30" KICK PLATE | RAC30TKBBMS   |
| MODERNIST SILVER STAINLESS STEEL - 30" KICK PLATE   | RAC30TKBBSR   |
| GRAPHITE STAINLESS STEEL - MODERNIST HANDLE         | RACOOMHAAMS   |
| SILVER STAINLESS STEEL - MODERNIST HANDLE           | RACOOMHAASR   |
| SILVER STAINLESS STEEL - HERITAGE PRO HANDLE        | RACOOPHAASR   |
| SILVER STAINLESS STEEL - EPICURE HANDLE             | ADRRZHIE  |
| PAIR INSTALLATION KIT                               | RACOOCPAAAA   |
| WATER FILTER  | RACOOWFAAAA   |
| DEODORIZING FILTER                                  | RACOODFAAAA   |



# 36-INCH REFRIGERATOR COLUMN, LEFT-HINGE PANEL-READY

DRR36980LAP



## PRODUCT FEATURES

- Full height door with true flush cabinet integration without exposed venting grille
- SteelCool™ Stainless Steel Interior illuminated by 3DLighting™
- Push-To-Open™ Door Assist opens the door upon a slight push for a luxuriously convenient experience
- Internal Water Dispenser for easy access to clean, filtered water
- iQ RemoteView™ Cameras (Wi-Fi) enables users to check what's in your fridge from your phone

## TEMPERATURE RANGES

|                           |                                      |
|---------------------------|--------------------------------------|
| REFRIGERATOR              | 34°F (1°C) TO 44°F (7°C)             |
| REFRIGERATOR - POWER COOL | 34°F (1°C)                           |
| FRESHZONE™ DRAWER         | 37°F (3°C) / 33°F (-1°C)/29°F (-1°C) |

## DIMENSIONS & WEIGHT

|  |                               |
|--|-------------------------------|
| APPLIANCE DIMENSIONS (H X W X D) (IN.) | 83 3/8" X 35 3/4" X 23 13/16" |
| REQUIRED CUTOUT SIZE (H X W X D) (IN.) | 84" X 36" X 25"               |
| NET WEIGHT (LBS)                       | 567                           |

## GENERAL PROPERTIES

|  |  |
|--|--|
| PANEL READY                                      | YES  |
| DOOR SWING                                       | LEFT   |
| PUSH-TO-OPEN™ DOOR ASSIST                        | YES  |
| INTERNAL WATER DISPENSER                         | YES  |
| iQ REMOTEVIEW™ CAMERA                            | YES (2 EA)   |
| DEODORIZING FILTER                               | YES  |
| LIGHTING   | 3DLIGHTING™  |
| INTERIOR MATERIAL                                | STEELCOOL™ STAINLESS STEEL INTERIOR                    |
| FULL WIDTH SHELVES                               | 4 EA   |
| SHELF MATERIAL                                   | TEMPERED GLASS SHELVES W/METAL TRIM                    |
| FULL EXTENSION DRAWERS AT 90° DOOR OPENING ANGLE | YES  |
| FRESHZONE™ DRAWER                                | YES - CHEESE (37°F) / COLD DRINKS (33°F) / MEAT (29°F) |
| CRISPER DRAWERS                                  | 2 EA   |
| DOOR BINS  | 4 EA   |
| DOOR OPEN ALARM                                  | YES  |
| SPECIAL MODES                                    | SABBATH MODE   |

## CAPACITY

|   |              |
|---|--------------|
| TOTAL UNIT GROSS CAPACITY (CU.FT.) - AHAM | 21.6 CU. FT. |
| REFRIGERATOR GROSS CAPACITY (CU.FT.)      | 21.6 CU. FT. |

## PERFORMANCE

|  |     |
|--|-----|
| DEDICATED EVAPORATOR & COMPRESSOR SYSTEM | YES |
| POWER COOL                               | YES |
| PRECISE COOLING                          | YES |

## EFFICIENCY

|                           |              |
|---------------------------|--------------|
| ENERGY STAR QUALIFIED     | YES          |
| ANNUAL ENERGY CONSUMPTION | 290 KWH/YEAR |

## TECHNICAL DETAILS

|                         |                |
|-------------------------|----------------|
| CURRENT (A)             | 3              |
| VOLTS (V)               | 115            |
| FREQUENCY (HZ)          | 60             |
| POWER CORD LENGTH (IN.) | 78 3/4"        |
| PLUG TYPE               | 120 V, 3 PRONG |

## WARRANTY

|  |                   |
|--|-------------------|
| LIMITED, ENTIRE APPLIANCE, PARTS AND LABOR ON ANY PART OF THE REFRIGERATOR | 2 YEAR            |
| LIMITED WARRANTY FOR SEALED REFRIGERATION SYSTEM; PARTS AND LABOR          | 3RD TO 6TH YEAR   |
| LIMITED WARRANTY FOR SEALED REFRIGERATION SYSTEM; PARTS ONLY               | 7TH TO 12TH YEAR  |
| LIMITED WARRANTY FOR COMPRESSOR; PARTS ONLY                                | 13TH TO 15TH YEAR |

### APPLIANCE DIMENSIONS

|                                 |                    |
|---------------------------------|--------------------|
| A (TOTAL WIDTH INCL. PANELS)    | 35 3/4" (908 MM)   |
| B (TOTAL DEPTH WITH 3/4" PANEL) | 25" (635 MM)       |
| C (HEIGHT)                      | 83 3/8" (2118 MM)  |
| D                               | 35 5/8" (905 MM)   |
| E                               | 62 7/8" (1597 MM)  |
| F                               | 20 9/16" (496 MM)  |
| G                               | 61 5/16" (1556 MM) |

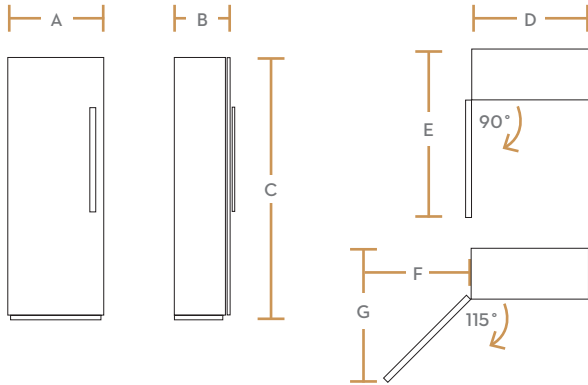

### CUSTOM PANEL DIMENSIONS

|              |                   |
|--------------|-------------------|
| A-1 (WIDTH)  | 35 3/4" (908MM)   |
| A-2 (HEIGHT) | 79 7/8" (2,029MM) |
| A-3 (DEPTH)  | 3/4" (19MM)       |
| MAX WEIGHT   | 66.0 LBS. (30KG)  |

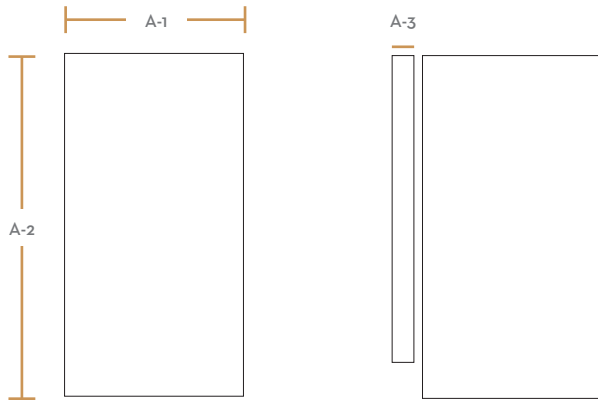

### INSTALLATION CUTOUT DIMENSIONS

|            |               |
|------------|---------------|
| A (WIDTH)  | 36" (914MM)   |
| B (DEPTH)  | 25" (635MM)   |
| C (HEIGHT) | 84" (2,134MM) |
| A'         | 9" (228MM)    |
| B'         | 26" (660MM)   |
| C'         | 80" (2,032MM) |

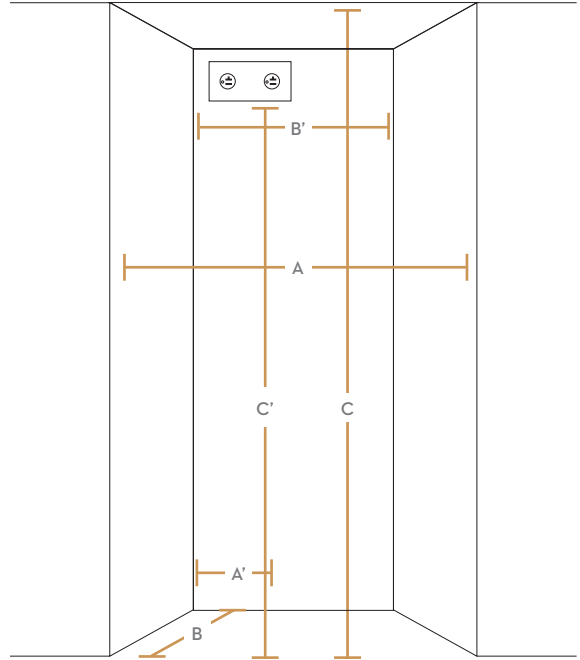

### ACCESSORIES

|   |             |
|---|-------------|
| GRAPHITE STAINLESS STEEL - 36" PANEL (LEFT HINGE) | RAC36DPLHMS |
| GRAPHITE STAINLESS STEEL - 36" KICK PLATE         | RAC36TKBBMS |
| GRAPHITE STAINLESS STEEL - MODERNIST HANDLE       | RAC00MHAAMS |
| SILVER STAINLESS STEEL - 36" PANEL (LEFT HINGE)   | RAC36DPLHSR |
| SILVER STAINLESS STEEL - 36" KICK PLATE           | RAC36TKBBSR |
| SILVER STAINLESS STEEL - MODERNIST HANDLE         | RAC00MHAASR |
| SILVER STAINLESS STEEL - DACOR PRO HANDLE         | RAC00PHAASR |
| PAIR INSTALLATION KIT                             | RAC00CPAAAA |
| WATER FILTER                                      | RAC00WFAAAA |
| DEODORIZING FILTER                                | RAC00DFAAAA |



# 36-INCH REFRIGERATOR COLUMN, RIGHT-HINGE PANEL-READY

DRR3698ORAP



## PRODUCT FEATURES

- Full height door with true flush cabinet integration without exposed venting grille
- SteelCool™ Stainless Steel Interior illuminated by 3DLighting™
- Push-To-Open™ Door Assist opens the door upon a slight push for a luxuriously convenient experience
- Internal Water Dispenser for easy access to clean, filtered water
- iQ RemoteView™ Cameras (Wi-Fi) enables users to check what's in your fridge from your phone

## TEMPERATURE RANGES

|                           |                                      |
|---------------------------|--------------------------------------|
| REFRIGERATOR              | 34°F (1°C) TO 44°F (7°C)             |
| REFRIGERATOR - POWER COOL | 34°F (1°C)                           |
| FRESHZONE™ DRAWER         | 37°F (3°C) / 33°F (-1°C)/29°F (-1°C) |

## DIMENSIONS & WEIGHT

|  |                               |
|--|-------------------------------|
| APPLIANCE DIMENSIONS (H X W X D) (IN.) | 83 3/8" X 35 3/4" X 23 13/16" |
| REQUIRED CUTOUT SIZE (H X W X D) (IN.) | 84" X 36" X 25"               |
| NET WEIGHT (LBS)                       | 567                           |

## GENERAL PROPERTIES

|  |  |
|--|--|
| PANEL READY                                      | YES  |
| DOOR SWING                                       | RIGHT  |
| PUSH-TO-OPEN™ DOOR ASSIST                        | YES  |
| INTERNAL WATER DISPENSER                         | YES  |
| IQ REMOTEVIEW™ CAMERA                            | YES (2 EA)   |
| DEODORIZING FILTER                               | YES  |
| LIGHTING   | 3DLIGHTING™  |
| INTERIOR MATERIAL                                | STEELCOOL™ STAINLESS STEEL INTERIOR                    |
| FULL WIDTH SHELVES                               | 4 EA   |
| SHELF MATERIAL                                   | TEMPERED GLASS SHELVES W/METAL TRIM                    |
| FULL EXTENSION DRAWERS AT 90° DOOR OPENING ANGLE | YES  |
| FRESHZONE™ DRAWER                                | YES - CHEESE (37°F) / COLD DRINKS (33°F) / MEAT (29°F) |
| CRISPER DRAWERS                                  | 2 EA   |
| DOOR BINS  | 4 EA   |
| DOOR OPEN ALARM                                  | YES  |
| SPECIAL MODES                                    | SABBATH MODE   |

## CAPACITY

|   |              |
|---|--------------|
| TOTAL UNIT GROSS CAPACITY (CU.FT.) - AHAM | 21.6 CU. FT. |
| REFRIGERATOR GROSS CAPACITY (CU.FT.)      | 21.6 CU. FT. |

## PERFORMANCE

|  |     |
|--|-----|
| DEDICATED EVAPORATOR & COMPRESSOR SYSTEM | YES |
| POWER COOL                               | YES |
| PRECISE COOLING                          | YES |

## EFFICIENCY

|                           |              |
|---------------------------|--------------|
| ENERGY STAR QUALIFIED     | YES          |
| ANNUAL ENERGY CONSUMPTION | 290 KWH/YEAR |

## TECHNICAL DETAILS

|                         |                |
|-------------------------|----------------|
| CURRENT (A)             | 3              |
| VOLTS (V)               | 115            |
| FREQUENCY (HZ)          | 60             |
| POWER CORD LENGTH (IN.) | 78 3/4"        |
| PLUG TYPE               | 120 V, 3 PRONG |

## WARRANTY

|  |                   |
|--|-------------------|
| LIMITED, ENTIRE APPLIANCE, PARTS AND LABOR ON ANY PART OF THE REFRIGERATOR | 2 YEAR            |
| LIMITED WARRANTY FOR SEALED REFRIGERATION SYSTEM; PARTS AND LABOR          | 3RD TO 6TH YEAR   |
| LIMITED WARRANTY FOR SEALED REFRIGERATION SYSTEM; PARTS ONLY               | 7TH TO 12TH YEAR  |
| LIMITED WARRANTY FOR COMPRESSOR; PARTS ONLY                                | 13TH TO 15TH YEAR |



# 36-INCH REFRIGERATOR COLUMN, RIGHT-HINGE PANEL-READY

## APPLIANCE DIMENSIONS

|                                 |                    |
|---------------------------------|--------------------|
| A (TOTAL WIDTH INCL. PANELS)    | 35 3/4" (908 MM)   |
| B (TOTAL DEPTH WITH 3/4" PANEL) | 25" (635 MM)       |
| C (HEIGHT)                      | 83 3/8" (2118MM)   |
| D                               | 35 5/8" (905 MM)   |
| E                               | 62 7/8" (1597 MM)  |
| F                               | 20 9/16" (496 MM)  |
| G                               | 61 5/16" (1556 MM) |

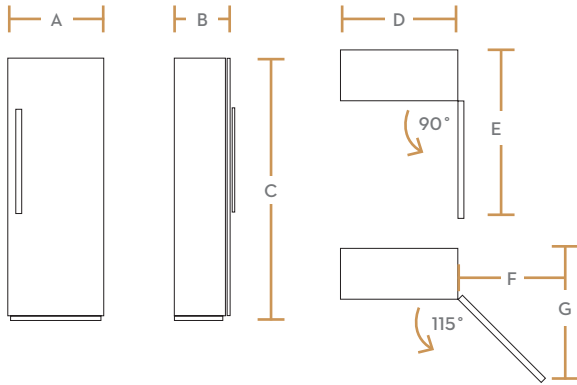

## INSTALLATION CUTOUT DIMENSIONS

|            |               |
|------------|---------------|
| A (WIDTH)  | 36" (914MM)   |
| B (DEPTH)  | 25" (635MM)   |
| C (HEIGHT) | 84" (2,134MM) |
| A'         | 9" (228MM)    |
| B'         | 26" (660MM)   |
| C'         | 80" (2,032MM) |

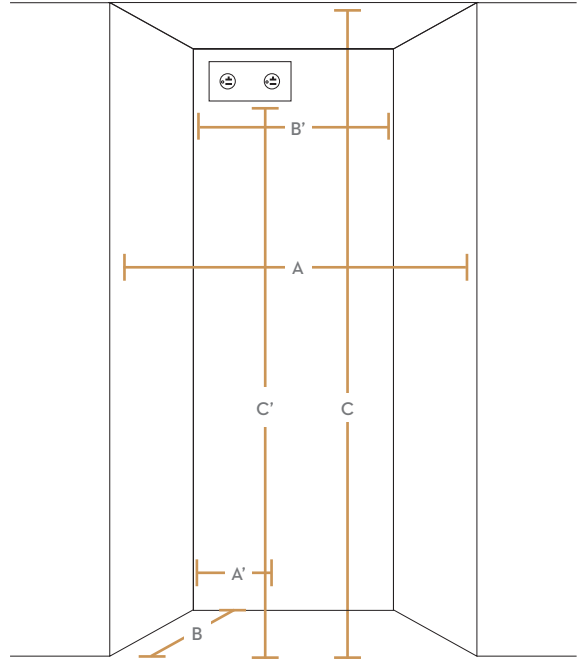

## CUSTOM PANEL DIMENSIONS

|              |                   |
|--------------|-------------------|
| A-1 (WIDTH)  | 35 3/4" (908MM)   |
| A-2 (HEIGHT) | 79 7/8" (2,029MM) |
| A-3 (DEPTH)  | 3/4" (19MM)       |
| MAX WEIGHT   | 66.0 LBS. (30KG)  |

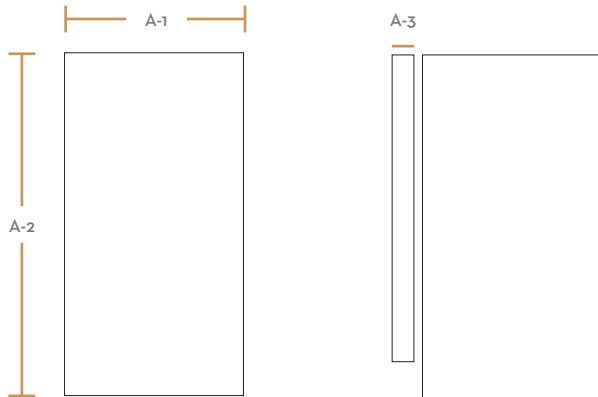

## ACCESSORIES

|  |             |
|--|-------------|
| GRAPHITE STAINLESS STEEL - 36" PANEL (RIGHT HINGE) | RAC36DPRHMS |
| GRAPHITE STAINLESS STEEL - 36" KICK PLATE          | RAC36TKBBMS |
| GRAPHITE STAINLESS STEEL - MODERNIST HANDLE        | RAC00MHAAMS |
| SILVER STAINLESS STEEL - 36" PANEL (RIGHT HINGE)   | RAC36DPRHSR |
| SILVER STAINLESS STEEL - 36" KICK PLATE            | RAC36TKBBSR |
| SILVER STAINLESS STEEL - MODERNIST HANDLE          | RAC00MHAASR |
| SILVER STAINLESS STEEL - DACOR PRO HANDLE          | RAC00PHAASR |
| PAIR INSTALLATION KIT                              | RAC00CPAAAA |
| WATER FILTER                                       | RAC00WFAAAA |
| DEODORIZING FILTER                                 | RAC00DFAAAA |