

DRR3090LAP
30-INCH REFRIGERATOR COLUMN, LEFT-HINGE
 MODERNIST, PANEL-READY

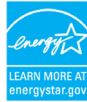

FEATURES & BENEFITS

- Full height door with true flush cabinet integration without exposed venting grille
- SteelCool™ Stainless Steel Interior Illuminated by 3DLighting™
- Push-To-Open™ Door Assist opens the door upon a slight push for a luxuriously convenient experience
- Internal Water Dispenser for easy access to clean, filtered water
- iQ RemoteView™ Cameras (Wi-Fi) enables users to check what's in your fridge from your phone

TEMPERATURE RANGES

Refrigerator	34°F (1°C) to 44°F (7°C)
Refrigerator - Power Cool	34°F (1°C)
FreshZone™ Drawer	37°F (3°C) / 33°F (1°C) / 29°F (-1°C)

ACCESSORIES (OPTIONAL)

Graphite Stainless Steel - 30" Panel (Left Hinge)	RAC30DPLHMS
Graphite Stainless Steel - 30" Kick Plate	RAC30TKBBMS
Graphite Stainless Steel - Modernist Handle	RAC00MHAAMS
Silver Stainless Steel - 30" Panel (Left Hinge)	RAC30DPLHSR
Silver Stainless Steel - 30" Kick Plate	RAC30TKBBBSR
Silver Stainless Steel - Modernist Handle	RAC00MHAASR
Silver Stainless Steel - Dacor Pro Handle	RAC00PHAASR
Pair Installation Kit	RAC00CPAAAA
Water Filter	RAC00WFAAAA
Deodorizing Filter	RAC00DFAAAA

GENERAL PROPERTIES

Panel Ready	Yes
Door Swing	Left
Push-To-Open™ Door Assist	Yes
Internal Water Dispenser	Yes
iQ RemoteView™ Camera	Yes (2 ea)
Deodorizing Filter	Yes
Lighting	3DLighting™
Interior Material	SteelCool™ Stainless Steel Interior
Full Width Shelves	4 ea
Shelf Material	Tempered, Metal Trim, Spill-Proof
Full Extension Drawers at 90° Door Opening Angle	Yes
FreshZone™ Drawer	Yes - Cheese (37°F) / Cold Drinks (33°F) / Meat (29°F)
Humidity Control Drawer	2 ea
Door Bins	4 ea
Door Open Alarm	Yes
Special Modes	Sabbath Mode

CAPACITY

Total Unit Gross Capacity (cu. ft.) - AHAM	17.8 cu. ft.
Refrigerator Gross Capacity (cu. ft.)	17.8 cu. ft.

PERFORMANCE

Dedicated Evaporator & Compressor System	Yes
Power Cool	Yes
Precise Cooling	Minimized temperature fluctuation ±0.36°F* (±0.2°C*)

TECHNICAL DETAILS

Current (A)	3
Volts (V)	115
Frequency (Hz)	60
Power Cord Length (in.)	78.34"
Plug Type	120V, 3 Prong

DIMENSIONS & WEIGHT

Appliance dimensions (H x W x D) (in.)	83 3/8" x 29 5/8" x 23 13/16"
Required Cutout Size (H x W x D) (in.)	84" x 30" x 25"
Net Weight (lbs)	472

EFFICIENCY

ENERGY STAR Qualified	Yes
Annual Energy Consumption	280 kW/year

WARRANTY

Limited, Entire Appliance, Parts and Labor on Any Part of the Refrigerator	2 Year
Limited Warranty for Sealed Refrigeration System; Parts and Labor	3rd to 6th Year
Limited Warranty for Sealed Refrigeration System; Parts Only	7th to 12th Year

DRR3090LAP

30-INCH REFRIGERATOR COLUMN, LEFT-HINGE

MODERNIST, PANEL-READY



APPLIANCE DIMENSIONS

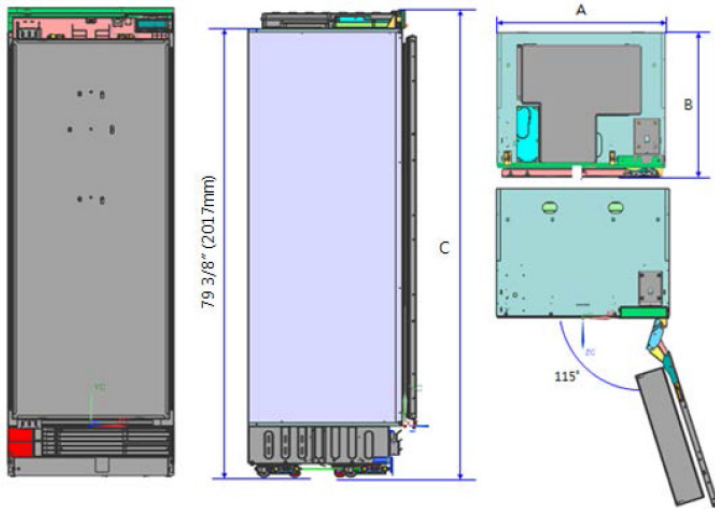

	30"
A (Width)	29 5/8" (752mm)
B (Depth)	23 13/16" (605mm)
C (Height)	83 3/8" (2118mm)

INSTALLATION CUTOUT DIMENSIONS

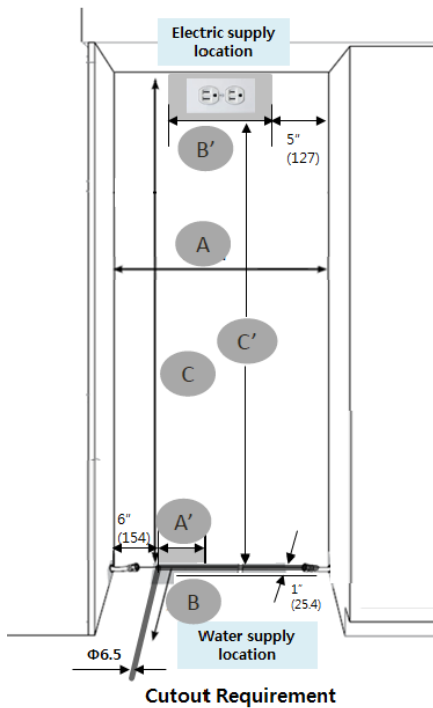

	30"
A (Width)	30" (762mm)
B (Depth)	25" (635mm)
C (Height)	84" (2134mm)
A'	6" (152mm)
B'	20" (508mm)
C'	80" (2032mm)

CUSTOM PANEL DIMENSIONS

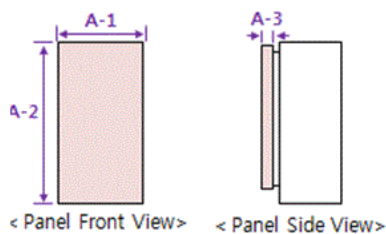

	30"
A-1 (Width)	29 3/4" (756mm)
A-2 (Height)	79 7/8" (2029mm)
A-3 (Depth)	3/4" (19mm)
Max Weight	88.0 lbs. (40kg)

DRR3090RAP

30-INCH REFRIGERATOR COLUMN, RIGHT-HINGE

MODERNIST, PANEL-READY



FEATURES & BENEFITS

- Full height door with true flush cabinet integration without exposed venting grille
- SteelCool™ Stainless Steel Interior Illuminated by 3DLighting™
- Push-To-Open™ Door Assist opens the door upon a slight push for a luxuriously convenient experience
- Internal Water Dispenser for easy access to clean, filtered water
- iQ RemoteView™ Cameras (Wi-Fi) enables users to check what's in your fridge from your phone

TEMPERATURE RANGES

Refrigerator	34°F (1°C) to 44°F (7°C)
Refrigerator - Power Cool	34°F (1°C)
FreshZone™ Drawer	37°F (3°C) / 33°F (1°C) / 29°F (-1°C)

ACCESSORIES (OPTIONAL)

Graphite Stainless Steel - 30" Panel (Right Hinge)	RAC30DPRHMS
Graphite Stainless Steel - 30" Kick Plate	RAC30TKBBMS
Graphite Stainless Steel - Modernist Handle	RAC00MHAAMS
Silver Stainless Steel - 30" Panel (Right Hinge)	RAC30DPRHSR
Silver Stainless Steel - 30" Kick Plate	RAC30TKBBBSR
Silver Stainless Steel - Modernist Handle	RAC00MHAASR
Silver Stainless Steel - Dacor Pro Handle	RAC00PHAASR
Pair Installation Kit	RAC00CPAAAA
Water Filter	RAC00WFAAAA
Deodorizing Filter	RAC00DFAAAA

GENERAL PROPERTIES

Panel Ready	Yes
Door Swing	Right
Push-To-Open™ Door Assist	Yes
Internal Water Dispenser	Yes
iQ RemoteView™ Camera	Yes (2 ea)
Deodorizing Filter	Yes
Lighting	3DLighting™
Interior Material	SteelCool™ Stainless Steel Interior
Full Width Shelves	4 ea
Shelf Material	Tempered, Metal Trim, Spill-Proof
Full Extension Drawers at 90° Door Opening Angle	Yes
FreshZone™ Drawer	Yes - Cheese (37°F) / Cold Drinks (33°F) / Meat (29°F)
Humidity Control Drawer	2 ea
Door Bins	4 ea
Door Open Alarm	Yes
Special Modes	Sabbath Mode

CAPACITY

Total Unit Gross Capacity (cu. ft.) - AHAM	17.8 cu. ft.
Refrigerator Gross Capacity (cu. ft.)	17.8 cu. ft.

PERFORMANCE

Dedicated Evaporator & Compressor System	Yes
Power Cool	Yes
Precise Cooling	Minimized temperature fluctuation ±0.36°F* (±0.2°C*)

TECHNICAL DETAILS

Current (A)	3
Volts (V)	115
Frequency (Hz)	60
Power Cord Length (in.)	78.34"
Plug Type	120V, 3 Prong

DIMENSIONS & WEIGHT

Appliance dimensions (H x W x D) (in.)	83 3/8" x 29 5/8" x 23 13/16"
Required Cutout Size (H x W x D) (in.)	84" x 30" x 25"
Net Weight (lbs)	472

EFFICIENCY

ENERGY STAR Qualified	Yes
Annual Energy Consumption	280 kW/year

WARRANTY

Limited, Entire Appliance, Parts and Labor on Any Part of the Refrigerator	2 Year
Limited Warranty for Sealed Refrigeration System; Parts and Labor	3rd to 6th Year
Limited Warranty for Sealed Refrigeration System; Parts Only	7th to 12th Year

DRR3090RAP

30-INCH REFRIGERATOR COLUMN, RIGHT-HINGE MODERNIST, PANEL-READY



APPLIANCE DIMENSIONS

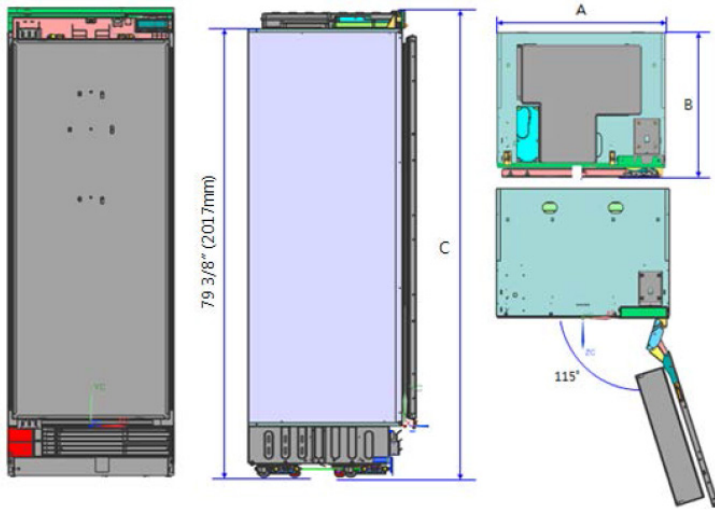

	30"
A (Width)	29 5/8" (752mm)
B (Depth)	23 13/16" (605mm)
C (Height)	83 3/8" (2118mm)

INSTALLATION CUTOUT DIMENSIONS

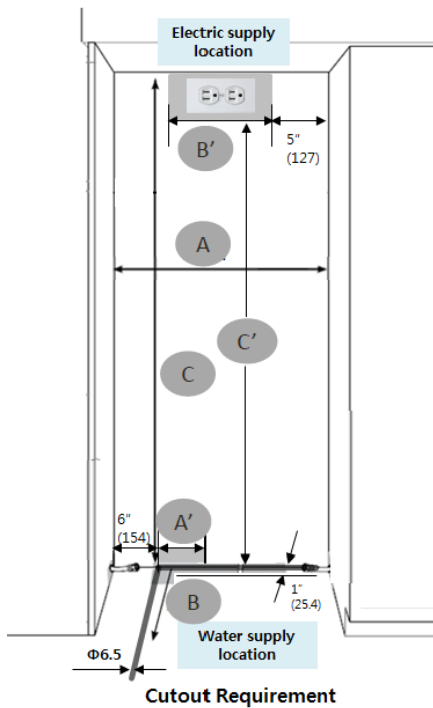

	30"
A (Width)	30" (762mm)
B (Depth)	25" (635mm)
C (Height)	84" (2134mm)
A'	6" (152mm)
B'	20" (508mm)
C'	80" (2032mm)

CUSTOM PANEL DIMENSIONS

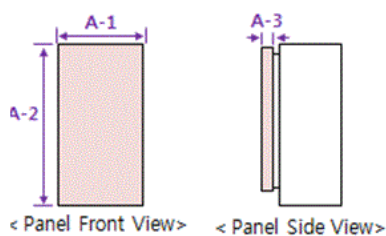

	30"
A-1 (Width)	29 3/4" (756mm)
A-2 (Height)	79 7/8" (2029mm)
A-3 (Depth)	3/4" (19mm)
Max Weight	88.0 lbs. (40kg)



30-INCH FREEZER COLUMN, PANEL-READY

DRZ30980RAP | DRZ30980LAP



PRODUCT FEATURES

- Full height door with true flush cabinet integration without exposed venting grille
- SteelCool™ Stainless Steel Interior Illuminated by 3DLighting™
- Push-To-Open™ Door Assist opens the door upon a slight push for a luxuriously convenient experience
- Dual icemaker with Standard and Cocktail Ice™
- Best-in class food preservation with dedicated evaporator/compressor and Precise Cooling Technology

TEMPERATURE RANGES

FREEZER	5°F (-15°C) TO -8°F (-23°C)
FREEZER - POWER FREEZE	-8°F (-23°C)

DIMENSIONS & WEIGHT

APPLIANCE DIMENSIONS (W X H X D) (IN.)	29 3/4" X 83 3/8" X 25"
REQUIRED CUTOUT SIZE (W X H X D) (IN.)	30" X 84" X 25"
NET WEIGHT (LBS)	483

GENERAL PROPERTIES

PANEL READY	YES
DOOR SWING	LAP-LEFT, RAP-RIGHT
PUSH-TO-OPEN™ DOOR ASSIST	YES
ICEMAKER	DUAL ICEMAKER FOR STANDARD AND COCKTAIL ICE™
LIGHTING	3DLIGHTING™
INTERIOR MATERIAL	STEELCOOL™ STAINLESS STEEL INTERIOR
FULL WIDTH SHELVES	3 EA
SHELF MATERIAL	TEMPERED, METAL TRIM, SPILL-PROOF
FULL EXTENSION DRAWERS AT 90° DOOR OPENING ANGLE	YES
HIDDEN COMPARTMENT WITH FLIP-UP COVER	1 EA
FREEZER DRAWER	2 EA
DOOR BINS	4 EA
DOOR OPEN ALARM	YES
SPECIAL MODES	SABBATH MODE

CAPACITY

TOTAL UNIT GROSS CAPACITY (CU.FT.) - AHAM	176 CU. FT.
REFRIGERATOR GROSS CAPACITY (CU.FT.)	176 CU. FT.

PERFORMANCE

DEDICATED EVAPORATOR & COMPRESSOR SYSTEM	YES
POWER FREEZE	YES
DEFROST PROCESS	FROST-FREE
PRECISE COOLING	YES

EFFICIENCY

ENERGY STAR QUALIFIED	YES
ANNUAL ENERGY CONSUMPTION	550 KWH/YEAR

TECHNICAL DETAILS

CURRENT (A)	15
VOLTS (V)	115
FREQUENCY (HZ)	60
POWER CORD LENGTH (IN.)	78 3/4"
PLUG TYPE	120 V, 3 PRONG

WARRANTY

LIMITED, ENTIRE APPLIANCE, PARTS AND LABOR ON ANY PART OF THE REFRIGERATOR	2 YEAR
LIMITED WARRANTY FOR SEALED REFRIGERATION SYSTEM; PARTS AND LABOR	3 RD TO 6 TH YEAR
LIMITED WARRANTY FOR SEALED REFRIGERATION SYSTEM; PARTS ONLY	7 TH TO 12 TH YEAR
LIMITED WARRANTY FOR COMPRESSOR; PARTS ONLY	13 TH TO 15 TH YEAR



30-INCH FREEZER COLUMN, PANEL-READY

APPLIANCE DIMENSIONS

A (WIDTH)	29 3/4" (756 MM)
B (WITH PANEL)	25" (635 MM)
B1 (WITHOUT PANEL)	23 13/16" (605MM)
C (HEIGHT)	83 3/8" (2118MM)
D	29 5/8" (752 MM)
D1 (WITH PANEL)	30 7/8" (784 MM)
D2 (WITH MODERNIST HANDLE)	32 3/4" (832 MM)
D3 (WITH PRO HANDLE)	33 3/8" (848 MM)
E	56 11/16" (1440 MM)
F	16 9/16" (421 MM)
G	55 5/16" (1404 MM)

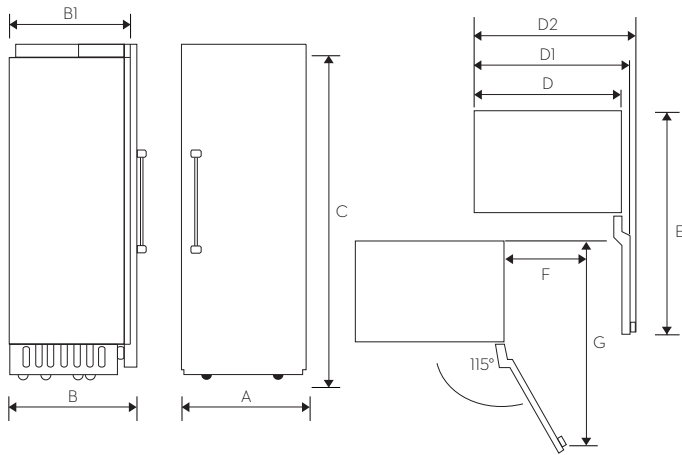

INSTALLATION CUTOUT DIMENSIONS

A (WIDTH)	30" (762MM)
B (DEPTH)	25" (635MM)
C (HEIGHT)	84" (2,134MM)
D	20" (508MM)
E	80" (2,032MM)

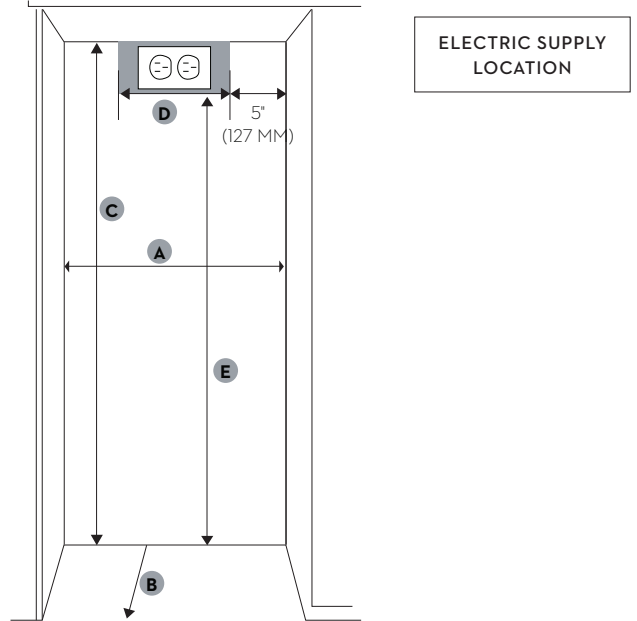

CUSTOM PANEL DIMENSIONS

A-1 (WIDTH)	29 3/4" (756MM)
A-2 (HEIGHT)	79 7/8" (2,029MM)
A-3 (DEPTH)	3/4" (19MM)
MAX WEIGHT	88.0 LBS. (40KG)

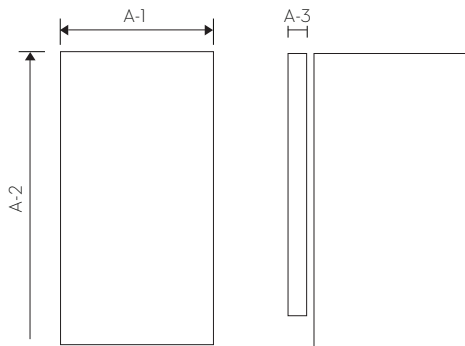

WATER SUPPLY CONNECTION REQUIREMENTS

A	6" (154 MM)
---	-------------

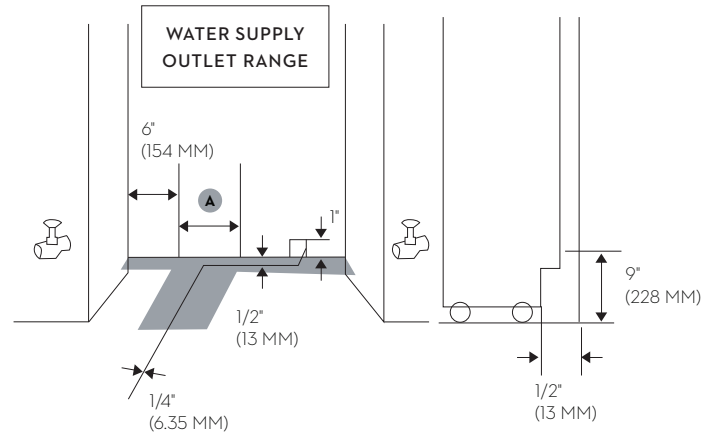

ACCESSORIES

MODERNIST GRAPHITE STAINLESS STEEL - 30" PANEL KIT	RAC30AMRHMS (RIGHT HINGE), RAC30AMLHMS (LEFT HINGE)
MODERNIST SILVER STAINLESS STEEL - 30" PANEL KIT	RAC30AMRHSR (RIGHT HINGE), RAC30AMLHSR (LEFT HINGE)
HERITAGE PRO SILVER STAINLESS STEEL - 30" PANEL KIT	RAC30AHRHSR (RIGHT HINGE), RAC30AHLHSR (LEFT HINGE)
MODERNIST GRAPHITE STAINLESS STEEL - 30" KICK PLATE	RAC30TKBBMS
MODERNIST SILVER STAINLESS STEEL - 30" KICK PLATE	RAC30TKBBSR
GRAPHITE STAINLESS STEEL - MODERNIST HANDLE	RACOOMHAAMS
SILVER STAINLESS STEEL - MODERNIST HANDLE	RACOOMHAASR
SILVER STAINLESS STEEL - HERITAGE PRO HANDLE	RACOPHAASR
SILVER STAINLESS STEEL - EPICURE HANDLE	ADRRZHIE
PAIR INSTALLATION KIT	RACOOCPAAAA
WATER FILTER	RACOOWFAAAA
DEODORIZING FILTER	RACOODFAAAA