



30-INCH REFRIGERATOR COLUMN, LEFT-HINGE PANEL-READY

DRR30980LAP



PRODUCT FEATURES

- Full height door with true flush cabinet integration without exposed venting grille
- SteelCool™ Stainless Steel Interior illuminated by 3DLighting™
- Push-To-Open™ Door Assist opens the door upon a slight push for a luxuriously convenient experience
- Internal Water Dispenser for easy access to clean, filtered water
- iQ RemoteView™ Cameras (Wi-Fi) enables users to check what's in your fridge from your phone

TEMPERATURE RANGES

REFRIGERATOR	34°F (1°C) TO 44°F (7°C)
REFRIGERATOR - POWER COOL	34°F (1°C)
FRESHZONE™ DRAWER	37°F (3°C) / 33°F (-1°C)/29°F (-1°C)

DIMENSIONS & WEIGHT

APPLIANCE DIMENSIONS (H X W X D) (IN.)	83 3/8" X 29 5/8" X 23 13/16"
REQUIRED CUTOUT SIZE (H X W X D) (IN.)	84" X 30" X 25"
NET WEIGHT (LBS)	472

GENERAL PROPERTIES

PANEL READY	YES
DOOR SWING	LEFT
PUSH-TO-OPEN™ DOOR ASSIST	YES
INTERNAL WATER DISPENSER	YES
IQ REMOTEVIEW™ CAMERA	YES (2 EA)
DEODORIZING FILTER	YES
LIGHTING	3DLIGHTING™
INTERIOR MATERIAL	STEELCOOL™ STAINLESS STEEL INTERIOR
FULL WIDTH SHELVES	4 EA
SHELF MATERIAL	TEMPERED, METAL TRIM, SPILL-PROOF
FULL EXTENSION DRAWERS AT 90° DOOR OPENING ANGLE	YES
FRESHZONE™ DRAWER	YES - CHEESE (37°F) / COLD DRINKS (33°F) / MEAT (29°F)
CRISPER DRAWERS	2 EA
DOOR BINS	4 EA
DOOR OPEN ALARM	YES
SPECIAL MODES	SABBATH MODE

CAPACITY

TOTAL UNIT GROSS CAPACITY (CU.FT.) - AHAM	17.8 CU. FT.
REFRIGERATOR GROSS CAPACITY (CU.FT.)	17.8 CU. FT.

PERFORMANCE

DEDICATED EVAPORATOR & COMPRESSOR SYSTEM	YES
POWER COOL	YES
PRECISE COOLING	YES

EFFICIENCY

ENERGY STAR QUALIFIED	YES
ANNUAL ENERGY CONSUMPTION	280 KWH/YEAR

TECHNICAL DETAILS

CURRENT (A)	3
VOLTS (V)	115
FREQUENCY (HZ)	60
POWER CORD LENGTH (IN.)	78 3/4"
PLUG TYPE	120 V, 3 PRONG

WARRANTY

LIMITED, ENTIRE APPLIANCE, PARTS AND LABOR ON ANY PART OF THE REFRIGERATOR	2 YEAR
LIMITED WARRANTY FOR SEALED REFRIGERATION SYSTEM; PARTS AND LABOR	3RD TO 6TH YEAR
LIMITED WARRANTY FOR SEALED REFRIGERATION SYSTEM; PARTS ONLY	7TH TO 12TH YEAR
LIMITED WARRANTY FOR COMPRESSOR; PARTS ONLY	13TH TO 15TH YEAR

APPLIANCE DIMENSIONS

A (TOTAL WIDTH INCL. PANELS)	29 3/4" (756 MM)
B (TOTAL DEPTH WITH 3/4" PANEL)	25" (635 MM)
C (HEIGHT)	83 3/8" (2118MM)
D	29 5/8" (752 MM)
E	56 11/16" (1440 MM)
F	16 9/16" (421 MM)
G	55 5/16" (1404 MM)

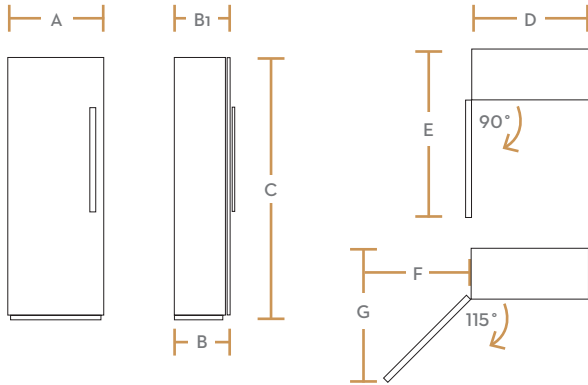

INSTALLATION CUTOUT DIMENSIONS

A (WIDTH)	30" (762MM)
B (DEPTH)	25" (635MM)
C (HEIGHT)	84" (2,134MM)
A'	6" (152MM)
B'	20" (508MM)
C'	80" (2,032MM)

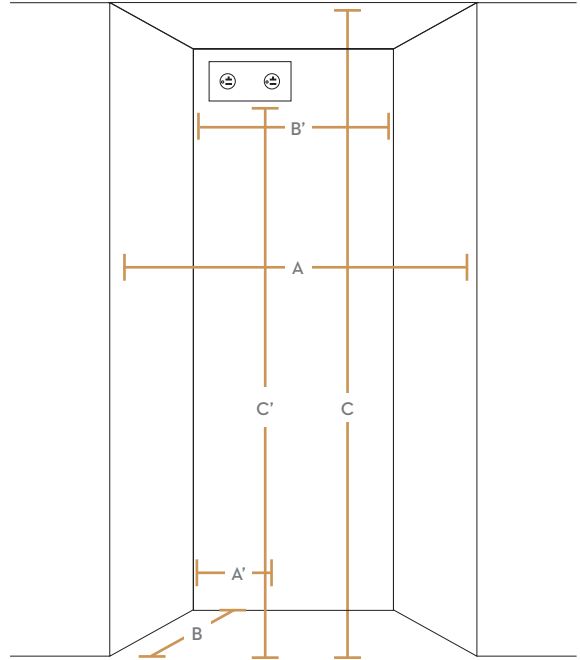

CUSTOM PANEL DIMENSIONS

A-1 (WIDTH)	29 3/4" (756MM)
A-2 (HEIGHT)	79 7/8" (2,029MM)
A-3 (DEPTH)	3/4" (19MM)
MAX WEIGHT	88.0 LBS. (40KG)

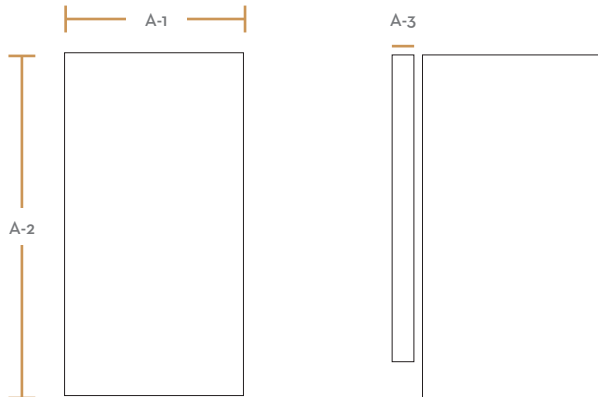

ACCESSORIES

GRAPHITE STAINLESS STEEL - 30" PANEL (LEFT HINGE)	RAC30DPLHMS
GRAPHITE STAINLESS STEEL - 30" KICK PLATE	RAC30TKBBMS
GRAPHITE STAINLESS STEEL - MODERNIST HANDLE	RAC00MHAAMS
SILVER STAINLESS STEEL - 30" PANEL (LEFT HINGE)	RAC30DPLHSR
SILVER STAINLESS STEEL - 30" KICK PLATE	RAC30TKBBSR
SILVER STAINLESS STEEL - MODERNIST HANDLE	RAC00MHAASR
SILVER STAINLESS STEEL - DACOR PRO HANDLE	RAC00PHAASR
PAIR INSTALLATION KIT	RAC00CPAAAA
WATER FILTER	RAC00WFAAAA
DEODORIZING FILTER	RAC00DFAAAA



30-INCH REFRIGERATOR COLUMN, RIGHT-HINGE PANEL-READY

DRR30980RAP



PRODUCT FEATURES

- Full height door with true flush cabinet integration without exposed venting grille
- SteelCool™ Stainless Steel Interior illuminated by 3DLighting™
- Push-To-Open™ Door Assist opens the door upon a slight push for a luxuriously convenient experience
- Internal Water Dispenser for easy access to clean, filtered water
- iQ RemoteView™ Cameras (Wi-Fi) enables users to check what's in your fridge from your phone

TEMPERATURE RANGES

REFRIGERATOR	34°F (1°C) TO 44°F (7°C)
REFRIGERATOR - POWER COOL	34°F (1°C)
FRESHZONE™ DRAWER	37°F (3°C) / 33°F (-1°C)/29°F (-1°C)

DIMENSIONS & WEIGHT

APPLIANCE DIMENSIONS (H X W X D) (IN.)	83 3/8" X 29 5/8" X 23 13/16"
REQUIRED CUTOUT SIZE (H X W X D) (IN.)	84" X 30" X 25"
NET WEIGHT (LBS)	472

GENERAL PROPERTIES

PANEL READY	YES
DOOR SWING	RIGHT
PUSH-TO-OPEN™ DOOR ASSIST	YES
INTERNAL WATER DISPENSER	YES
IQ REMOTEVIEW™ CAMERA	YES (2 EA)
DEODORIZING FILTER	YES
LIGHTING	3DLIGHTING™
INTERIOR MATERIAL	STEELCOOL™ STAINLESS STEEL INTERIOR
FULL WIDTH SHELVES	4 EA
SHELF MATERIAL	TEMPERED, METAL TRIM, SPILL-PROOF
FULL EXTENSION DRAWERS AT 90° DOOR OPENING ANGLE	YES
FRESHZONE™ DRAWER	YES - CHEESE (37°F) / COLD DRINKS (33°F) / MEAT (29°F)
CRISPER DRAWERS	2 EA
DOOR BINS	4 EA
DOOR OPEN ALARM	YES
SPECIAL MODES	SABBATH MODE

CAPACITY

TOTAL UNIT GROSS CAPACITY (CU.FT.) - AHAM	17.8 CU. FT.
REFRIGERATOR GROSS CAPACITY (CU.FT.)	17.8 CU. FT.

PERFORMANCE

DEDICATED EVAPORATOR & COMPRESSOR SYSTEM	YES
POWER COOL	YES
PRECISE COOLING	YES

EFFICIENCY

ENERGY STAR QUALIFIED	YES
ANNUAL ENERGY CONSUMPTION	280 KWH/YEAR

TECHNICAL DETAILS

CURRENT (A)	3
VOLTS (V)	115
FREQUENCY (HZ)	60
POWER CORD LENGTH (IN.)	78 3/4"
PLUG TYPE	120 V, 3 PRONG

WARRANTY

LIMITED, ENTIRE APPLIANCE, PARTS AND LABOR ON ANY PART OF THE REFRIGERATOR	2 YEAR
LIMITED WARRANTY FOR SEALED REFRIGERATION SYSTEM; PARTS AND LABOR	3RD TO 6TH YEAR
LIMITED WARRANTY FOR SEALED REFRIGERATION SYSTEM; PARTS ONLY	7TH TO 12TH YEAR
LIMITED WARRANTY FOR COMPRESSOR; PARTS ONLY	13TH TO 15TH YEAR

APPLIANCE DIMENSIONS

A (TOTAL WIDTH INCL. PANELS)	29 3/4" (756 MM)
B (TOTAL DEPTH WITH 3/4" PANEL)	25" (635 MM)
C (HEIGHT)	83 3/8" (2118MM)
D	29 5/8" (752 MM)
E	56 11/16" (1440 MM)
F	16 9/16" (421 MM)
G	55 5/16" (1404 MM)

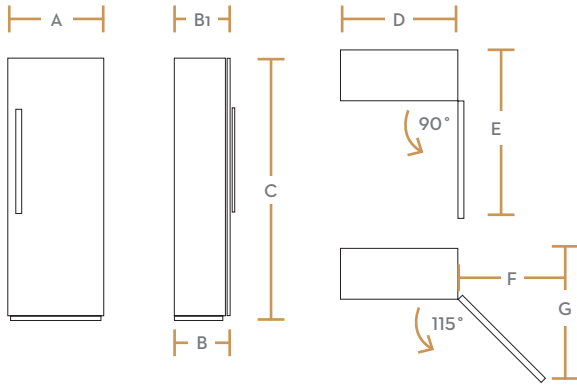

INSTALLATION CUTOUT DIMENSIONS

A (WIDTH)	30" (762MM)
B (DEPTH)	25" (635MM)
C (HEIGHT)	84" (2,134MM)
A'	6" (152MM)
B'	20" (508MM)
C'	80" (2,032MM)

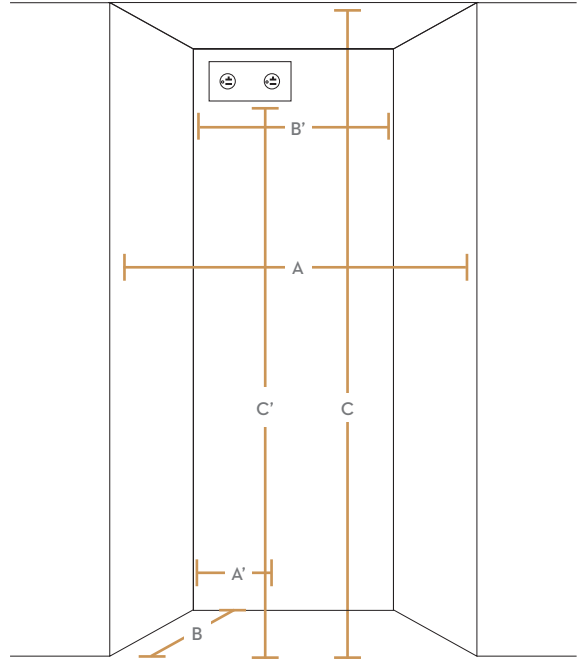

CUSTOM PANEL DIMENSIONS

A-1 (WIDTH)	29 3/4" (756MM)
A-2 (HEIGHT)	79 7/8" (2,029MM)
A-3 (DEPTH)	3/4" (19MM)
MAX WEIGHT	88.0 LBS. (40KG)

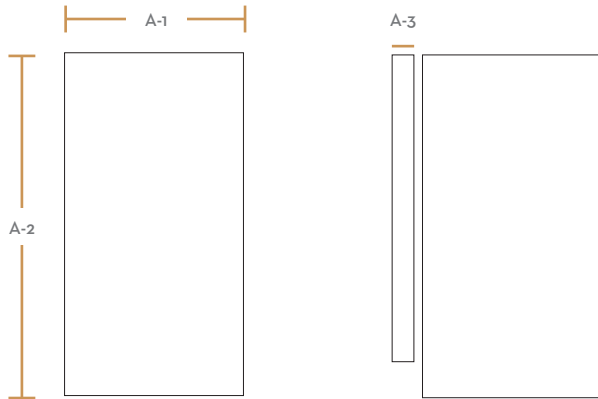

ACCESSORIES

GRAPHITE STAINLESS STEEL - 30" PANEL (RIGHT HINGE)	RAC30DPRHMS
GRAPHITE STAINLESS STEEL - 30" KICK PLATE	RAC30TKBBMS
GRAPHITE STAINLESS STEEL - MODERNIST HANDLE	RAC00MHAAMS
SILVER STAINLESS STEEL - 30" PANEL (RIGHT HINGE)	RAC30DPRHSR
SILVER STAINLESS STEEL - 30" KICK PLATE	RAC30TKBBSR
SILVER STAINLESS STEEL - MODERNIST HANDLE	RAC00MHAASR
SILVER STAINLESS STEEL - DACOR PRO HANDLE	RAC00PHAASR
PAIR INSTALLATION KIT	RAC00CPAAAA
WATER FILTER	RAC00WFAAAA
DEODORIZING FILTER	RAC00DFAAAA



24-INCH FREEZER COLUMN, LEFT-HINGE PANEL-READY

DRZ24980LAP



PRODUCT FEATURES

- Full height door with true flush cabinet integration without exposed venting grille
- SteelCool™ Stainless Steel Interior illuminated by 3DLighting™
- Push-To-Open™ Door Assist opens the door upon a slight push for a luxuriously convenient experience
- Dual IceMaker with Standard and Cocktail Ice™
- Best-in class food preservation with dedicated evaporator/compressor and Precise Cooling Technology

TEMPERATURE RANGES

FREEZER	5°F (-15°C) TO -8°F (-23°C)
FREEZER - POWER FREEZE	-8°F (-23°C)

DIMENSIONS & WEIGHT

APPLIANCE DIMENSIONS (H X W X D) (IN.)	83 3/8" X 23 5/8" X 23 13/16"
REQUIRED CUTOUT SIZE (H X W X D) (IN.)	84" X 24" X 25"
NET WEIGHT (LBS)	386

GENERAL PROPERTIES

PANEL READY	YES
DOOR SWING	LEFT
PUSH-TO-OPEN™ DOOR ASSIST	YES
ICEMAKER	DUAL ICEMAKER FOR STANDARD AND COCKTAIL ICE™
LIGHTING	3DLIGHTING™
INTERIOR MATERIAL	STEELCOOL™ STAINLESS STEEL INTERIOR
FULL WIDTH SHELVES	3 EA
SHELF MATERIAL	TEMPERED, METAL TRIM, SPILL-PROOF
FULL EXTENSION DRAWERS AT 90° DOOR OPENING ANGLE	YES
HIDDEN COMPARTMENT WITH FLIP-UP COVER	1 EA
FREEZER DRAWER	2 EA
DOOR BINS	4 EA
DOOR OPEN ALARM	YES
SPECIAL MODES	SABBATH MODE

CAPACITY

TOTAL UNIT GROSS CAPACITY (CU.FT.) - AHAM	13.6 CU. FT.
REFRIGERATOR GROSS CAPACITY (CU.FT.)	13.6 CU. FT.

PERFORMANCE

DEDICATED EVAPORATOR & COMPRESSOR SYSTEM	YES
POWER FREEZE	YES
DEFROST PROCESS	FROST-FREE
PRECISE COOLING	YES

EFFICIENCY

ENERGY STAR QUALIFIED	YES
ANNUAL ENERGY CONSUMPTION	500 KWH/YEAR

TECHNICAL DETAILS

CURRENT (A)	3
VOLTS (V)	115
FREQUENCY (HZ)	60
POWER CORD LENGTH (IN.)	78 3/4"
PLUG TYPE	120 V, 3 PRONG

WARRANTY

LIMITED, ENTIRE APPLIANCE, PARTS AND LABOR ON ANY PART OF THE REFRIGERATOR	2 YEAR
LIMITED WARRANTY FOR SEALED REFRIGERATION SYSTEM; PARTS AND LABOR	3RD TO 6TH YEAR
LIMITED WARRANTY FOR SEALED REFRIGERATION SYSTEM; PARTS ONLY	7TH TO 12TH YEAR
LIMITED WARRANTY FOR COMPRESSOR; PARTS ONLY	13TH TO 15TH YEAR

APPLIANCE DIMENSIONS

A (TOTAL WIDTH INCL. PANELS)	23 3/4" (603 MM)
B (TOTAL DEPTH WITH 3/4" PANEL)	25" (635 MM)
C (HEIGHT)	83 3/8" (2118MM)
D	23 5/8" (600 MM)
E	50 3/4" (1289 MM)
F	13 11/16" (348 MM)
G	49 11/16" (1261 MM)

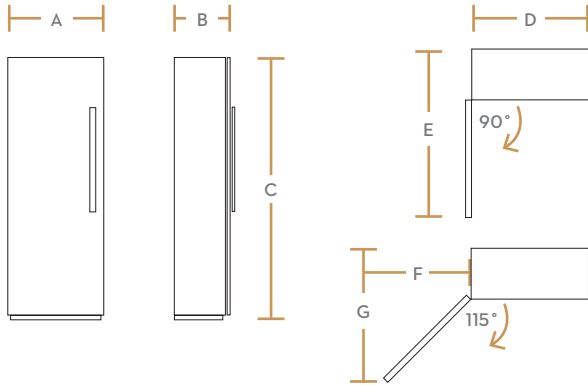

INSTALLATION CUTOUT DIMENSIONS

A (WIDTH)	24" (610MM)
B (DEPTH)	25" (635MM)
C (HEIGHT)	84" (2,134MM)
A'	5 1/2" (140MM)
B'	14" (356MM)
C'	80" (2,032MM)

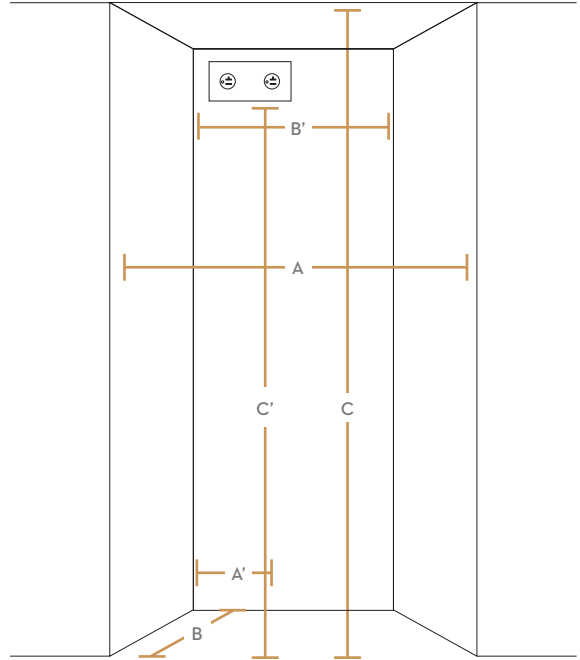

CUSTOM PANEL DIMENSIONS

A-1 (WIDTH)	23 3/4" (603MM)
A-2 (HEIGHT)	79 7/8" (2,029MM)
A-3 (DEPTH)	3/4" (19MM)
MAX WEIGHT	110.0 LBS. (50KG)

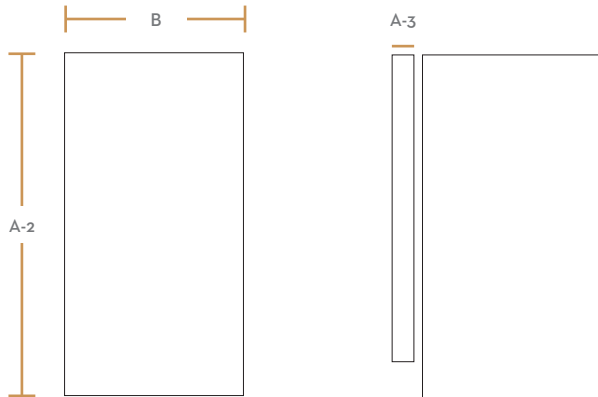

ACCESSORIES

GRAPHITE STAINLESS STEEL - 24" PANEL (LEFT HINGE)	RAC24DPLHMS
GRAPHITE STAINLESS STEEL - 24" KICK PLATE	RAC24TKBBMS
GRAPHITE STAINLESS STEEL - MODERNIST HANDLE	RAC00MHAAMS
SILVER STAINLESS STEEL - 24" PANEL (LEFT HINGE)	RAC24DPLHSR
SILVER STAINLESS STEEL - 24" KICK PLATE	RAC24TKBBSR
SILVER STAINLESS STEEL - MODERNIST HANDLE	RAC00MHAASR
SILVER STAINLESS STEEL - DACOR PRO HANDLE	RAC00PHAASR
PAIR INSTALLATION KIT	RAC00CPAAAA
WATER FILTER	RAC00WFAAAA
DEODORIZING FILTER	RAC00DFAAAA



24-INCH FREEZER COLUMN, RIGHT-HINGE PANEL-READY

DRZ2498ORAP



PRODUCT FEATURES

- Full height door with true flush cabinet integration without exposed venting grille
- SteelCool™ Stainless Steel Interior illuminated by 3DLighting™
- Push-To-Open™ Door Assist opens the door upon a slight push for a luxuriously convenient experience
- Dual Icemaker with Standard and Cocktail Ice™
- Best-in class food preservation with dedicated evaporator/compressor and Precise Cooling Technology

TEMPERATURE RANGES

FREEZER	5°F (-15°C) TO -8°F (-23°C)
FREEZER - POWER FREEZE	-8°F (-23°C)

DIMENSIONS & WEIGHT

APPLIANCE DIMENSIONS (H X W X D) (IN.)	83 3/8" X 23 5/8" X 23 13/16"
REQUIRED CUTOUT SIZE (H X W X D) (IN.)	84" X 24" X 25"
NET WEIGHT (LBS)	386

GENERAL PROPERTIES

PANEL READY	YES
DOOR SWING	RIGHT
PUSH-TO-OPEN™ DOOR ASSIST	YES
ICEMAKER	DUAL ICEMAKER FOR STANDARD AND COCKTAIL ICE™
LIGHTING	3DLIGHTING™
INTERIOR MATERIAL	STEELCOOL™ STAINLESS STEEL INTERIOR
FULL WIDTH SHELVES	3 EA
SHELF MATERIAL	TEMPERED, METAL TRIM, SPILL-PROOF
FULL EXTENSION DRAWERS AT 90° DOOR OPENING ANGLE	YES
HIDDEN COMPARTMENT WITH FLIP-UP COVER	1 EA
FREEZER DRAWER	2 EA
DOOR BINS	4 EA
DOOR OPEN ALARM	YES
SPECIAL MODES	SABBATH MODE

CAPACITY

TOTAL UNIT GROSS CAPACITY (CU.FT.) - AHAM	13.6 CU. FT.
REFRIGERATOR GROSS CAPACITY (CU.FT.)	13.6 CU. FT.

PERFORMANCE

DEDICATED EVAPORATOR & COMPRESSOR SYSTEM	YES
POWER FREEZE	YES
DEFROST PROCESS	FROST-FREE
PRECISE COOLING	YES

EFFICIENCY

ENERGY STAR QUALIFIED	YES
ANNUAL ENERGY CONSUMPTION	500 KWH/YEAR

TECHNICAL DETAILS

CURRENT (A)	3
VOLTS (V)	115
FREQUENCY (HZ)	60
POWER CORD LENGTH (IN.)	78 3/4"
PLUG TYPE	120 V, 3 PRONG

WARRANTY

LIMITED, ENTIRE APPLIANCE, PARTS AND LABOR ON ANY PART OF THE REFRIGERATOR	2 YEAR
LIMITED WARRANTY FOR SEALED REFRIGERATION SYSTEM; PARTS AND LABOR	3RD TO 6TH YEAR
LIMITED WARRANTY FOR SEALED REFRIGERATION SYSTEM; PARTS ONLY	7TH TO 12TH YEAR
LIMITED WARRANTY FOR COMPRESSOR; PARTS ONLY	13TH TO 15TH YEAR

APPLIANCE DIMENSIONS

A (TOTAL WIDTH INCL. PANELS)	23 3/4" (603 MM)
B (TOTAL DEPTH WITH 3/4" PANEL)	25" (635 MM)
C (HEIGHT)	83 3/8" (2118MM)
D	23 5/8" (600 MM)
E	50 3/4" (1289 MM)
F	13 11/16" (348 MM)
G	49 11/16" (1261 MM)

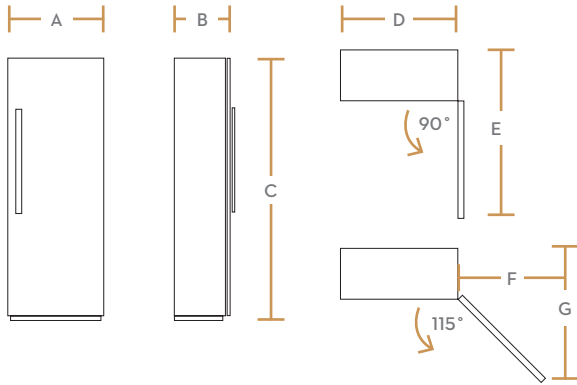

CUSTOM PANEL DIMENSIONS

A-1 (WIDTH)	23 3/4" (603MM)
A-2 (HEIGHT)	79 7/8" (2,029MM)
A-3 (DEPTH)	3/4" (19MM)
MAX WEIGHT	110.0 LBS. (50KG)

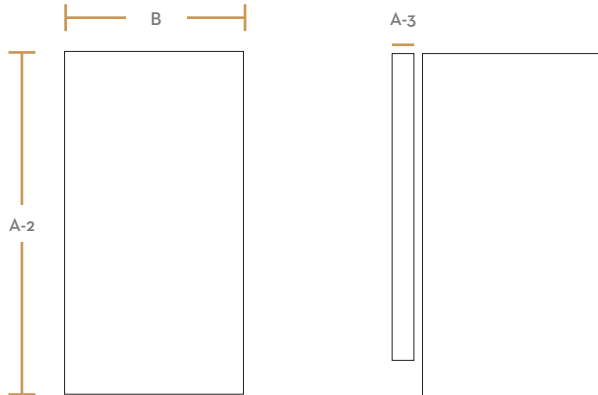

INSTALLATION CUTOUT DIMENSIONS

A (WIDTH)	24" (610MM)
B (DEPTH)	25" (635MM)
C (HEIGHT)	84" (2,134MM)
A'	5 1/2" (140MM)
B'	14" (356MM)
C'	80" (2,032MM)

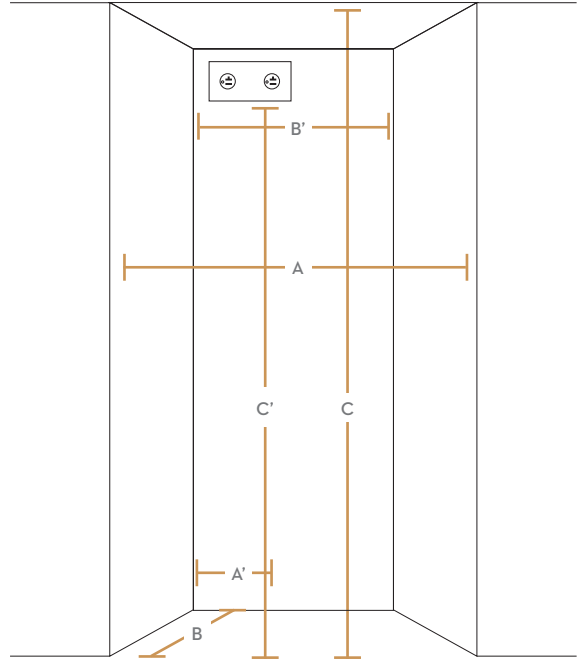

ACCESSORIES

GRAPHITE STAINLESS STEEL - 24" PANEL (RIGHT HINGE)	RAC24DPRHMS
GRAPHITE STAINLESS STEEL - 24" KICK PLATE	RAC24TKBBMS
GRAPHITE STAINLESS STEEL - MODERNIST HANDLE	RAC00MHAAMS
SILVER STAINLESS STEEL - 24" PANEL (RIGHT HINGE)	RAC24DPRHSR
SILVER STAINLESS STEEL - 24" KICK PLATE	RAC24TKBBSR
SILVER STAINLESS STEEL - MODERNIST HANDLE	RAC00MHAASR
SILVER STAINLESS STEEL - DACOR PRO HANDLE	RAC00PHAASR
PAIR INSTALLATION KIT	RAC00CPAAAA
WATER FILTER	RAC00WFAAAA
DEODORIZING FILTER	RAC00DFAAAA